



A New Live Trap for the Acoustically Orienting Parasitoid Fly *Emblemasoma erro* (Diptera: Sarcophagidae)

Author: Stucky, Brian J.

Source: Florida Entomologist, 99(3) : 559-562

Published By: Florida Entomological Society

URL: <https://doi.org/10.1653/024.099.0337>

BioOne Complete (complete.BioOne.org) is a full-text database of 200 subscribed and open-access titles in the biological, ecological, and environmental sciences published by nonprofit societies, associations, museums, institutions, and presses.

Your use of this PDF, the BioOne Complete website, and all posted and associated content indicates your acceptance of BioOne's Terms of Use, available at www.bioone.org/terms-of-use.

Usage of BioOne Complete content is strictly limited to personal, educational, and non - commercial use. Commercial inquiries or rights and permissions requests should be directed to the individual publisher as copyright holder.

BioOne sees sustainable scholarly publishing as an inherently collaborative enterprise connecting authors, nonprofit publishers, academic institutions, research libraries, and research funders in the common goal of maximizing access to critical research.

A new live trap for the acoustically orienting parasitoid fly *Emblemasoma erro* (Diptera: Sarcophagidae)

Brian J. Stucky^{1,2,*}

Ever since the discovery that some species of parasitoid flies are attracted to the acoustic mating calls of their host insects (Cade 1975; Soper et al. 1976), researchers have exploited the phonotactic host-finding behaviors of these eavesdropping parasitoids as a means for collecting them in the field. Typically, a loudspeaker is used to broadcast an audio signal that mimics the sounds of the parasitoids' hosts, and parasitoids that are attracted to the loudspeaker are either collected by hand (e.g., Soper et al. 1976; Fowler & Kochalka 1985; Wagner 1996; Lakes-Harlan et al. 2000; Köhler & Lakes-Harlan 2001; de Vries & Lakes-Harlan 2005; Wagner & Basolo 2007) or captured using sticky traps (e.g., Fowler 1987; Walker 1993; Allen 1998; Kolluru & Zuk 2001), electrified wire grids (Mangold 1978; Walker 1986), or custom-built live traps (e.g., Cade 1975, 1979; Fowler 1988; Walker 1989; Allen et al. 1999). However, if non-destructive, automated sampling is desired, then live traps are the only viable option.

Detailed plans have been published for live traps to catch two species of tachinid acoustic parasitoids, *Ormia ochracea* (Bigot) (Diptera: Tachinidae) (Cade 1979; Walker 1989) and *O. depleta* (Wiedemann) (Fowler 1988). These traps all use the same basic principle of a box with an internal loudspeaker at one end and one or more inverted funnels or slits that guide flies to the box's interior. The slit trap design of Walker (1989) (or variations on his design) has been the most widely used (e.g., Walker 1993; Gray & Cade 1999; Gray et al. 2007; Farris et al. 2008; Vincent & Bertram 2010a,b).

In all published designs, the entrances to the funnels or tapered slits leading to the interior of the trap occupy a rather small portion of the outer area of the trap (e.g., in Fowler's most successful design, the entrances to the funnels leading to the trap's interior account for only about 3% of the outer surface area) or are restricted to only one side of the trap, as with Cade's and Walker's designs. Flies that land on these traps might therefore need to spend considerable time exploring the trap's exterior before they find an entrance leading to the loudspeaker. This evidently causes little problem for trapping acoustic parasitoids such as *O. ochracea* that spend several minutes or more at a sound source searching for possible larviposition sites (Cade 1975; Walker 1989; Allen et al. 1999), but not all species of acoustic parasitoids exhibit such behavior.

Emblemasoma erro Aldrich (Diptera: Sarcophagidae) is an acoustic parasitoid of cicadas (Hemiptera: Cicadidae) in central North America (Stucky 2015), and in 2010, I began a series of field studies that required trapping live *E. erro*. From preliminary observations of *E. erro*'s phonotactic response to a loudspeaker broadcasting cicada calls, I found that individuals of *E. erro* often departed only a few seconds after initially approaching the loudspeaker, or, if they

stayed longer, engaged in little exploratory walking around the sound source. Thus, traps that require parasitoids to persistently search the trap's exterior to find an entrance seemed unlikely to work well for *E. erro*.

Here, I describe a new acoustic live trap specifically designed for acoustic parasitoids such as *E. erro* whose phonotactic behaviors differ from those of *O. ochracea* and similar species. The initial design was completed during the summer of 2011, and tests of the trap's performance were conducted in 2011 and 2012 at field sites in Geary, McPherson, and Reno counties in central Kansas.

The trap consists of two main components (Figs. 1 and 2). First, the "speaker box" is a simple wooden box with an upward-facing loudspeaker mounted in the middle of the top face and a piece of aluminum window screen covering the aperture of the speaker to pre-



Fig. 1. The complete live trap deployed in the field. Captured flies are visible in the holding jar assembly at the top of the trap box.

¹University of Colorado, Department of Ecology and Evolutionary Biology, Boulder, Colorado 80309, USA

²University of Florida, Florida Museum of Natural History, Gainesville, Florida 32611, USA

*E-mail: stuckyb@colorado.edu

Supplementary material for this article in Florida Entomologist 99(3) (Sep 2016) is online at <http://purl.fcla.edu/fcla/entomologist/browse>

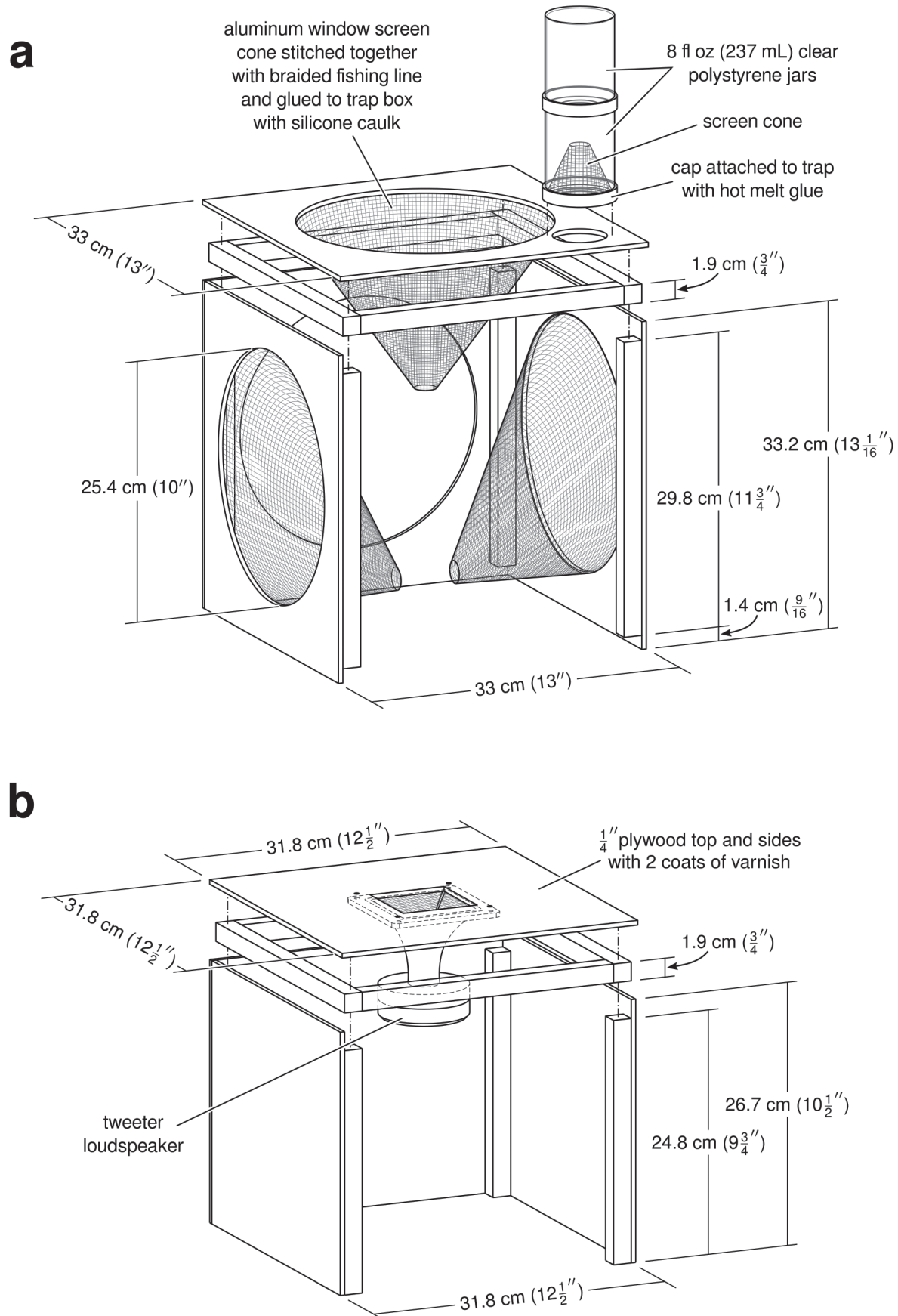

Fig. 2. Details of trap construction showing a) the trap box and b) the speaker box. To reveal internal components, the front-facing, side plywood panels of the trap and speaker boxes are not illustrated. Also, for clarity, only 3 of the 5 wire screen cones of the trap box are illustrated.

vent flies from contacting the loudspeaker's components. Pyle PH44 loudspeakers (Pyle Audio Inc., Brooklyn, New York) were used for trap design and testing, but most "tweeter" loudspeakers should have an appropriate frequency response range for reproducing insect sounds. Tweeters should generally be used with a high-pass filter of some sort (such as an in-line capacitor) to avoid audio distortion or speaker damage caused by low frequencies.

The second main trap component, the "trap box," is an approximate cube with extensions on the bottom to fit securely over the speaker box. Each vertical side of the trap box has an oblique, circular screen cone leading toward the loudspeaker, and the top of the trap box has a screen cone leading directly downward toward the center of the loudspeaker. Patterns for cutting the cones out of flat aluminum window screen are provided as supplementary data for this paper (online at <http://purl.fcla.edu/fcla/entomologist/browse>). The top of the trap box has a jar assembly for retaining captured flies similar in design to that of Walker (1989).

This trap design includes two elements that set it apart from previous acoustic traps. First, unlike published trap designs, a large portion of the external area of the trap box is occupied by the outer entrances of the cones leading to the trap's interior (just over 46%). Second, the oblique cones on the sides give flies direct paths to the loudspeaker from most locations on the outside of the trap box. These two features were intended to minimize the time required for *E. erro* to locate an entrance to the trap's interior, and observations in the field confirmed that many flies were able to access the interior of the trap within a few seconds of their initial arrival.

Although the side entrance funnels make the trap more labor intensive to construct than top-entrance-only designs, such as that of Walker (1989), field tests confirmed that the side entrances are especially important for capturing *E. erro*. Of 85 flies observed entering the traps during tests in 2012, 81 (95.3%) entered through one of the side cones whereas only 4 (4.7%) entered from the top. If flies have no preference for how they enter the trap, they would be expected to enter through the top with probability 0.2 and through the sides with probability 0.8 (the opening diameters of all 5 entrance cones are the same). A 2-tailed binomial test of the data rejected this null hypothesis ($P < 0.001$), indicating that flies preferentially entered the trap through the sides rather than the top. The 95% confidence interval for the proportion of flies that entered through one of the sides, using the method of Wilson (Wilson 1927; Agresti & Coull 1998), was 0.885–0.982.

Other advantages of this trap design are its light weight and modularity. The combined mass of the speaker box and trap box (not including the mass of the speaker and mounting hardware, which are brand dependent) was 2.88 kg (average of 3 complete traps), so the traps are quite portable. The modular design of the trap, with separate speaker box and trap box components, makes the speaker box convenient to use by itself for manual collecting, simple presence/absence surveys, or behavioral observations.

If the trap is to be operated continuously for long periods of time (e.g., more than an hour or two), a more spacious holding jar assembly at the top of the trap is recommended to avoid excessive crowding. Crowding appeared to agitate the flies and increase the chances that they left the holding jar assembly and returned to the main trap box, which could increase the probability of an escape.

Despite the trap's effectiveness, I observed many flies that either landed on the outside of the trap and then failed to move closer to the sound source, left before entering the trap, or approached the trap in flight but failed to land. Both Fowler (1988) and Walker (1989) reported similar results when testing their trap designs. Because flies that initially leave the trap sometimes make one or more return visits (B.

Stucky, personal observation), it is difficult to estimate the percentage of flies attracted to the trap that ultimately evade capture. It also was not obvious how the trap design could be further improved to increase the capture rate.

Nevertheless, my use of these traps over multiple field seasons has demonstrated both their utility for capturing *E. erro* and their suitability for routine field work. After dozens of hours of use in a variety of habitats, and capturing hundreds of flies, these traps have so far required virtually no maintenance. As a next step, it would be useful to assay the performance of this design for species of acoustic parasitoids besides *E. erro*. Tests with *O. depleta* would be especially interesting because this species proved difficult to capture with previous live trap designs (Fowler 1988).

Many thanks to Bruce Stucky for helping refine the trap design and for providing the tools and woodworking expertise needed for trap construction. I also thank Erin Stucky and Rob Guralnick for their comments on the manuscript and figures. This work was supported in part by funding from the University of Colorado Department of Ecology and Evolutionary Biology and the University of Colorado Museum of Natural History.

Summary

Parasitoids that locate their hosts by eavesdropping on the acoustic signals of other insects can be collected in traps baited with audio signals that mimic the sounds of the parasitoid's hosts. I describe a new acoustic trap designed to capture *Emblemasoma erro* Aldrich (Diptera: Sarcophagidae), an eavesdropping parasitoid of cicadas whose phonotactic behavior differs from that of the acoustic parasitoids targeted by previous trap designs. Specifically, unlike some other acoustic parasitoids, *E. erro* often remains at an artificial sound source only a few seconds, so the new trap features multiple, oblique side entrance funnels with large outer apertures that allow *E. erro* to rapidly access the trap's interior. The trap also has a modular design that allows the broadcast loudspeaker to be used independently of the trapping apparatus, and the trap is lightweight and easily transported in the field.

Key Words: eavesdropping; bioacoustics; host finding; insect trap; *Ormia*

Sumario

Los parasitoides que localizan sus hospederos por escuchar las señales acústicas de otros insectos pueden recogerse en trampas cebadas con señales de audio que imitan los sonidos de los hospederos del parasitoides. Describo una nueva trampa acústica diseñada para capturar *Emblemasoma erro* Aldrich (Diptera: Sarcophagidae), un parasitoides de las cigarras cuyo comportamiento fonotáctica difiere de la de los parasitoides acústicos que fueron el enfoque de los diseños de trampas anteriores. Específicamente, a diferencia de algunos otros parasitoides acústicos, *E. erro* a menudo se detiene en una fuente de sonido artificial sólo por unos pocos segundos, por lo que las nuevas características de la trampa presenta embudos oblicuos múltiples a la entrada lateral con grandes aberturas exteriores que permiten a *E. erro* acceder rápidamente el interior de la trampa. La trampa también tiene un diseño modular que permite al parlante ser utilizado independientemente del aparato de captura, y la trampa es de poco peso y es fácil de transportar en el campo.

Palabras Clave: escucha; bioacústica; búsqueda de hospedero; trampa para insectos; *Ormia*

References Cited

- Agresti A, Coull BA. 1998. Approximate is better than “exact” for interval estimation of binomial proportions. *The American Statistician* 52: 119.
- Allen GR. 1998. Diel calling activity and field survival of the bushcricket, *Sciarasaga quadrata* (Orthoptera: Tettigoniidae): a role for sound-locating parasitic flies? *Ethology* 104: 645–660.
- Allen GR, Kamien D, Berry O, Byrne P, Hunt J. 1999. Larviposition, host cues, and planidial behavior in the sound-locating parasitoid fly *Homotrixia alleni* (Diptera: Tachinidae). *Journal of Insect Behavior* 12: 67–79.
- Cade W. 1975. Acoustically orienting parasitoids: fly phonotaxis to cricket song. *Science* 190: 1312–1313.
- Cade W. 1979. The evolution of alternative male reproductive strategies in field crickets, pp. 343–379 *In* Blum MS, Blum NA [eds.], *Sexual Selection and Reproductive Competition in Insects*. Academic Press, New York, New York.
- de Vries T, Lakes-Harlan R. 2005. Phonotaxis of the female parasitoid *Emblemasoma auditrix* (Diptera, Sarcophagidae) in relation to number of larvae and age. *Zoology* 108: 239–246.
- Farris HE, Oshinsky ML, Forrest TG, Hoy RR. 2008. Auditory sensitivity of an acoustic parasitoid (*Emblemasoma* sp., Sarcophagidae, Diptera) and the calling behavior of potential hosts. *Brain, Behavior and Evolution* 72: 16–26.
- Fowler HG. 1987. Field behavior of *Euphasiopteryx depleta* (Diptera: Tachinidae): phonotactically orienting parasitoids of mole crickets (Orthoptera: Gryllotalpidae: *Scapteriscus*). *Journal of the New York Entomological Society* 95: 474–480.
- Fowler HG. 1988. Traps for collecting live *Euphasiopteryx depleta* (Diptera: Tachinidae) at a sound source. *Florida Entomologist* 71: 654–656.
- Fowler HG, Kochalka JN. 1985. New record of *Euphasiopteryx depleta* (Diptera: Tachinidae) from Paraguay: attraction to broadcast calls of *Scapteriscus acletus* (Orthoptera: Gryllotalpidae). *Florida Entomologist* 68: 225–226.
- Gray DA, Cade WH. 1999. Sex, death, and genetic variation: natural and sexual selection on cricket song. *Proceedings of the Royal Society B: Biological Sciences* 266: 707–709.
- Gray DA, Banuelos C, Walker S, Cade W, Zuk M. 2007. Behavioural specialization among populations of the acoustically orienting parasitoid fly *Ormia ochracea* utilizing different cricket species as hosts. *Animal Behaviour* 73: 99–104.
- Köhler U, Lakes-Harlan R. 2001. Auditory behaviour of a parasitoid fly (*Emblemasoma auditrix*, Sarcophagidae, Diptera). *Journal of Comparative Physiology A: Sensory, Neural, and Behavioral Physiology* 187: 581–587.
- Kolluru GR, Zuk M. 2001. Parasitism patterns and the size–fecundity relationship in the acoustically orienting dipteran parasitoid *Ormia ochracea*. *Canadian Journal of Zoology* 79: 973–979.
- Lakes-Harlan R, Stölting H, Moore TE. 2000. Phonotactic behaviour of a parasitoid fly (*Emblemasoma auditrix*, Diptera, Sarcophagidae) in response to the calling song of its host cicada (*Okanagana rimosa*, Homoptera, Cicadidae). *Zoology* 103: 31–39.
- Mangold JR. 1978. Attraction of *Euphasiopteryx ochracea*, *Corethrella* sp. and gryllids to broadcast songs of the southern mole cricket. *Florida Entomologist* 61: 57–61.
- Soper RS, Shewell GE, Tyrrell D. 1976. *Colcondamyia auditrix* nov. sp. (Diptera: Sarcophagidae), a parasite which is attracted by the mating song of its host, *Okanagana rimosa* (Homoptera: Cicadidae). *The Canadian Entomologist* 108: 61–68.
- Stucky BJ. 2015. Infection behavior, life history, and host parasitism rates of *Emblemasoma erro* (Diptera: Sarcophagidae), an acoustically hunting parasitoid of the cicada *Tibicen dorsatus* (Hemiptera: Cicadidae). *Zoological Studies* 54: 1–17.
- Vincent CM, Bertram SM. 2010a. Collection and laboratory culture of *Ormia ochracea* (Diptera: Tachinidae). *Journal of Entomological Science* 45: 1–7.
- Vincent CM, Bertram SM. 2010b. Crickets groom to avoid lethal parasitoids. *Animal Behaviour* 79: 51–56.
- Wagner WE. 1996. Convergent song preferences between female field crickets and acoustically orienting parasitoid flies. *Behavioral Ecology* 7: 279–285.
- Wagner WE, Basolo AL. 2007. Host preferences in a phonotactic parasitoid of field crickets: the relative importance of host song characters. *Ecological Entomology* 32: 478–484.
- Walker TJ. 1986. Monitoring the flights of field crickets (*Gryllus* spp.) and a tachinid fly (*Euphasiopteryx ochracea*) in north Florida. *Florida Entomologist* 69: 678–685.
- Walker TJ. 1989. A live trap for monitoring *Euphasiopteryx* and tests with *E. ochracea* (Diptera: Tachinidae). *Florida Entomologist* 72: 314–319.
- Walker TJ. 1993. Phonotaxis in female *Ormia ochracea* (Diptera: Tachinidae), a parasitoid of field crickets. *Journal of Insect Behavior* 6: 389–410.
- Wilson EB. 1927. Probable inference, the law of succession, and statistical inference. *Journal of the American Statistical Association* 22: 209.