

Integrative taxonomy suggests species status for *Philonthus sideropterus* Kolenati, 1846 sp. propr., the former color form of *Philonthus splendens* (Fabricius, 1793) (Coleoptera: Staphylinidae)

Authors: Geisler, Lucas, Hansen, Aslak Kappel, Shaw, Josh Jenkins, and Solodovnikov, Alexey

Source: Integrative Systematics: Stuttgart Contributions to Natural History, 7(1) : 9-23

Published By: Stuttgart State Museum of Natural History

URL: <https://doi.org/10.18476/2024.210366>

BioOne Complete (complete.BioOne.org) is a full-text database of 200 subscribed and open-access titles in the biological, ecological, and environmental sciences published by nonprofit societies, associations, museums, institutions, and presses.

Your use of this PDF, the BioOne Complete website, and all posted and associated content indicates your acceptance of BioOne's Terms of Use, available at www.bioone.org/terms-of-use.

Usage of BioOne Complete content is strictly limited to personal, educational, and non - commercial use. Commercial inquiries or rights and permissions requests should be directed to the individual publisher as copyright holder.

BioOne sees sustainable scholarly publishing as an inherently collaborative enterprise connecting authors, nonprofit publishers, academic institutions, research libraries, and research funders in the common goal of maximizing access to critical research.

RESEARCH ARTICLE

Integrative taxonomy suggests species status for *Philonthus sideropterus* Kolenati, 1846 sp. propr., the former color form of *Philonthus splendens* (Fabricius, 1793) (Coleoptera: Staphylinidae)

LUCAS GEISLER¹, ASLAK KAPPEL HANSEN^{1,2}, JOSH JENKINS SHAW¹ & ALEXEY SOLODOVNIKOV¹

Abstract

Philonthus splendens sideropterus Kolenati, 1846 (Coleoptera: Staphylinidae) was considered a Caucasian intraspecific form of the widespread West Palearctic *Philonthus splendens* (Fabricius, 1793) with an unclear diagnosis and volatile status. Mostly, it has been considered a variety of *P. splendens* or, recently, its subspecies, without firm justification. Using material from across the range of *P. splendens* and methods of integrative taxonomy, we conclude that *Philonthus sideropterus*, restricted to the forests of the Caucasus in the broad sense and north-eastern Asia Minor, and *Philonthus splendens*, confined to a broad range of habitats in the Euro-Siberian forest belt, represent two allopatric sister species. Their clear divergence in the *COI* barcode (4.3%), distinct morphological difference in elytral coloration, lack of transitional forms, and allopatric distribution prompted us to raise *Philonthus sideropterus* **sp. propr.** to species level. The origin of both sister species from their common ancestor can possibly be explained by the paleoclimatic fluctuations that fragmented the initially or periodically more widespread forest biota into the Eurasian forest belt and the montane forests of the Caucasian region. A lectotype is designated for *Philonthus splendens* (Fabricius, 1793).

Key words: DNA barcoding, genetic distance, allopatry, Palearctic, subspecies.

Zusammenfassung

Philonthus splendens sideropterus Kolenati, 1846 (Coleoptera: Staphylinidae) wurde als kaukasische intraspezifische Form des weit verbreiteten westpaläarktischen *Philonthus splendens* (Fabricius, 1793) mit unklarer Diagnose und unklarem Status angesehen. Meistens wurde er ohne eindeutige Begründung als eine Varietät von *P. splendens* oder in jüngerer Zeit als dessen Unterart angesehen. Anhand von Material aus dem gesamten Verbreitungsgebiet von *P. splendens* und Methoden der integrativen Taxonomie kommen wir zu dem Schluss, dass *Philonthus sideropterus*, der auf die Wälder des Kaukasus (im weiteren Sinn) und des nordöstlichen Kleinasien beschränkt ist, und *Philonthus splendens*, der in einem breiten Spektrum von Lebensräumen im eurosibirischen Waldgürtel verbreitet ist, zwei allopatrische Schwesterarten darstellen. Ihre deutliche Divergenz im *COI*-Barcode (4,3%), deutliche morphologische Unterschiede in der Flügeldeckenfärbung, das Fehlen von Übergangsformen und die allopatrische Verbreitung veranlassten uns, *Philonthus sideropterus* **sp. propr.** auf Artniveau zu heben. Die Abstammung der beiden Schwesterarten von ihrem gemeinsamen Vorfahren kann möglicherweise durch die paläoklimatischen Schwankungen erklärt werden, die die anfänglich oder zeitweise weiter verbreiteten Waldbiota in den eurasischen Waldgürtel und die Bergwälder der Kaukasusregion teilten. Für *Philonthus splendens* (Fabricius, 1793) wird ein Lectotypus festgelegt.

Introduction

Philonthus Stephens, 1829 is the second largest genus in the diverse beetle family Staphylinidae, containing over 1,250 species (HROMÁDKA 2008; CHANI-POSSE 2010). Many *Philonthus* species are very similar, their phylogenetic relationships are still poorly known (HROMÁDKA 2008; CHANI-POSSE 2010; SCHILLHAMMER 2012), and often they can be distinguished from each other only by subtle differences in the shape of the male genitalia or minute external characters. At the same time, many *Philonthus* display significant intraspecific morphological variation; in par-

ticular, the same species may have different color morphs, which is especially true for the species with a metallic coloration. Such clusters of closely related species would benefit from a rigorous study by means of integrative taxonomy; these, amongst others, include the *rotundicollis*, *picimanus*, and *formaneki* groups (SCHILLHAMMER 2003) as well as the *varians*, *longicornis*, *micans*, and other groups (SCHILLHAMMER 2009, 2012; HROMÁDKA 2012).

Integration of DNA data with morphology allows researchers to overcome some of the previous challenges faced by traditional taxonomy, and can help reveal cryptic species overlooked in the past (VITECEK et al. 2017;



Fig. 1. Habitus of *P. splendens* (A) and *P. sideropterus* (B), showing differences in elytral coloration.

BRUNKE et al. 2020; HANSEN & JENKINS SHAW 2023). Integrative taxonomy, as a tool for species delimitation, also involves a rigorous assessment of the distribution and bionomic data that were always valued by careful taxonomists. In Staphylinidae, methods of integrative taxonomy are gaining momentum, as summarized in GEBREMESKEL et al. (2023) and as exemplified by PARK et al.'s (2024) recent study on the morphologically variable and widespread *Philonthus nudus* Sharp. *Philonthus splendens* (Fabricius, 1793) and its reported intraspecific form, sometimes formally recognized as subspecies *P. s. sideropterus* Kolenati, 1846, are a noteworthy case suitable for careful integrative taxonomic examination (Fig. 1).

Philonthus splendens is a large predatory rove beetle between 12.0 and 16.5 mm in length, commonly collected and well-represented in museum collections. It typically has a shiny black body and its pronotum lacks the characteristic dorsal rows of punctures present in most *Philonthus* species. The elytra are often with a brass/bronze metallic luster. *Philonthus splendens* is the type species of the genus *Philonthus* and is distributed across Europe and large parts of Asia, with some records from North Africa (SCHILLHAMMER 2000). *Philonthus splendens* var. *sideropterus* is much less widespread, known only from the Caucasus region. It was first described from Trans-

caucasia by KOLENATI (1846) as having “Elytris cyaneis”, i.e., a cyan-blue metallic luster on the elytra in contrast to the brass/bronze of *P. splendens*, while otherwise being very similar to the latter. The seemingly non-overlapping geographical distributions of both *P. splendens* and *P. sideropterus* and their subtle morphological differences urged staphylinid taxonomists to consider them as varieties or subspecies (examples of habitats suitable for *P. splendens* and *P. sideropterus* are shown in Fig. 2). The ambiguity of the subspecies concept and lack of data showing a transition between both subspecies has further made the true categorization of *P. sideropterus* difficult. The blue-colored Transcaucasian form seems, as KOLENATI (1846) and several other authors (HOCHHUTH 1849; COIFFAIT 1967, 1974; SCHILLHAMMER 2000) noticed, endemic to the Caucasus. Caucasian variants of otherwise widespread species have often shown signs of speciation in various organismal groups, such as spiders (CHALADZE et al. 2014), plants (GAGNIDZE et al. 2002), and beetles (GEBREMESKEL et al. 2023; JUSTESEN et al. 2023), to mention just a few. The unique geological and climatic conditions of the Caucasus, with its diverse landscapes ranging from mountains and high plateaus to semi-arid lowlands, function as a southern refugium for several temperate species (MILNE & ABBOTT 2002; BERIDZE et al. 2023). Species previously with widespread populations were fragmented and/or isolated in the Caucasus due to the gradual uplift and cooling of the region in the Miocene and Pliocene (23.3–2.58 Ma) or the more recent climatic fluctuations in the Quaternary (2.58 Ma–present) (BURKE et al. 2018; HRIVNIAK et al. 2020; BERIDZE et al. 2023; HANSEN et al. 2023). Many of these isolated, remnant populations have presumably diverged enough from the originally widespread populations to become distinct species, making the Caucasus a biodiversity hotspot with high numbers of endemics (CHALADZE et al. 2014; VICTOROVICH & PAVLOVICH 2018).

To investigate the outlined case of *P. splendens* var. *sideropterus*, we here aim to study morphologically and molecularly a wide pool of material that covers the entire distribution of this species complex. For the molecular work, we targeted the widely accepted barcode fragment of the mitochondrial *COI* gene and the fragment of the nuclear *Wingless* gene. The *COI* barcode is widely used to delimit closely related species across most animal phyla (RATNASINGHAM & HEBERT 2007; Shearer & Coffroth 2008; GEBREMESKEL et al. 2023; GORRING & COGNATO 2023). The nuclear gene *Wingless* (*Wg*) was chosen as a supplement to *COI* due to its similar usage in other studies (TOUSSAINT et al. 2015; MUÑOZ-TOBAR & CATERINO 2020). To not rely solely on genetic evidence, we also performed a morphological assessment of targeted individuals as well as a careful mapping of the distribution of both color forms, an integrative approach.

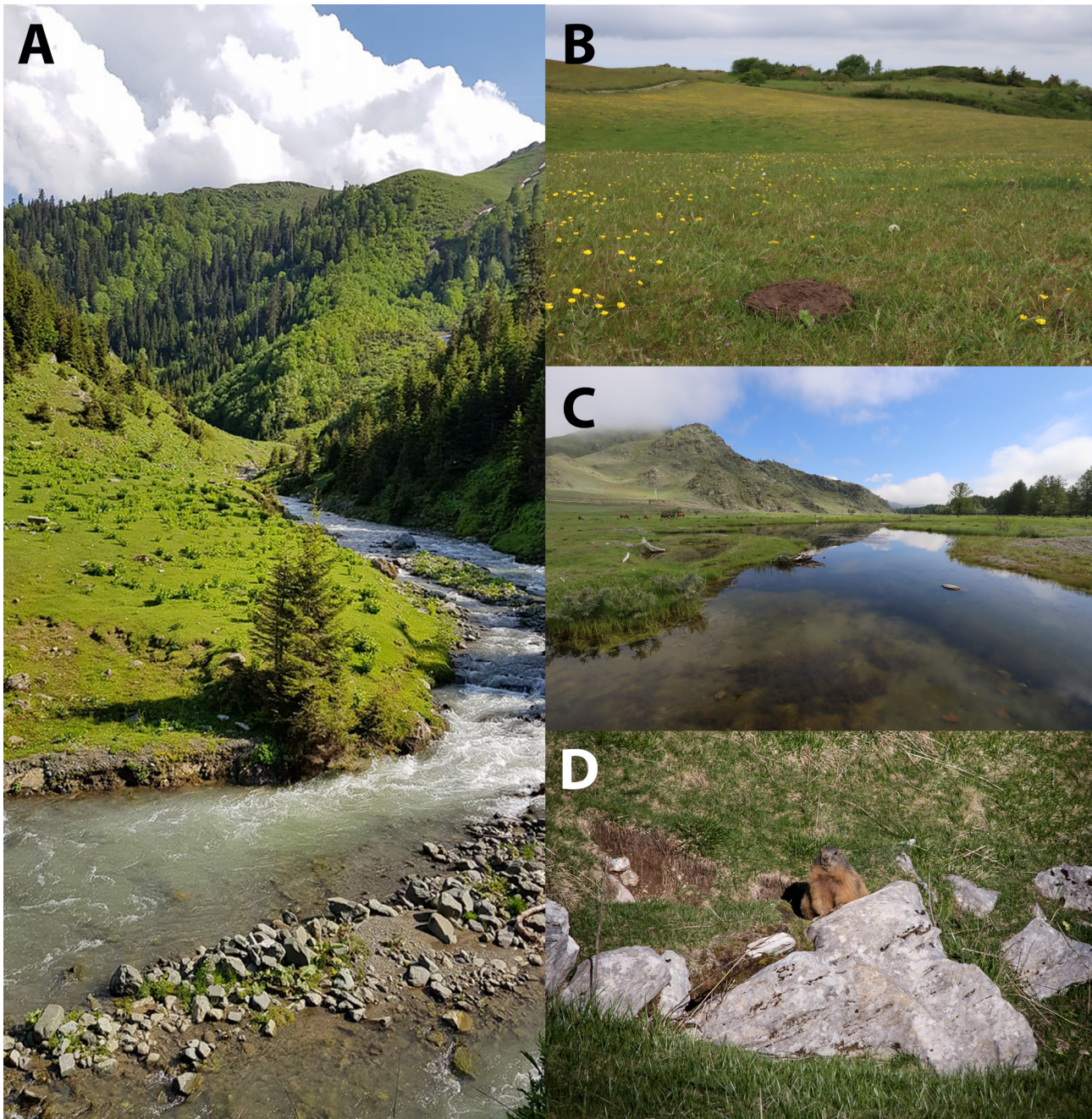

Fig. 2. Habitats of *P. splendens* and *P. sideropterus*. **A.** Bakhmaro, Georgia; *P. sideropterus* collected in cattle dung at 1900–2500m. **B.** Nekselø, Denmark; *P. splendens* collected in cattle dung near sea level. **C.** Altai, Russia; *P. splendens* collected in cattle dung at 1500m. **D.** Lessinia, Italy; *P. splendens* collected in nest debris near marmot burrow entrance at 1600 m.

Taxonomic history of *Philonthus splendens* var. *sideropterus*

Philonthus splendens var. *sideropterus* Kolenati, 1846 was described as a variant of *P. splendens* Fabricius, 1793 with cyan-colored elytra. No data on the type material is

mentioned in KOLENATI (1846), except that it originated from “Transcaucasia”. It is noteworthy that KOLENATI (1846) mentioned the possibility of *sideropterus* being a separate, new species. HOCHHUTH (1849) brought the first elaborate description of *P. splendens* var. *sideropterus* and reported one specimen collected from Tiflis (now Tbilisi,

Georgia) and three from Helenendorf (now Goygol, Azerbaijan). The first mention of a specimen that can be considered a syntype of *P. s. var. sideropterus* from the Caucasus was located at some “der Königl. Sammlung” by KRAATZ (1857). GANGLBAUER (1895) listed *sideropterus* as a synonym of *P. splendens* without any mention of its previous classification as a variant. This was repeated in the catalog of BERNHAUER & SCHUBERT (1914), who also listed it as a synonym. Contrary to this, the catalog by SCHEERPELTZ (1933) returned to the taxonomic differentiation between *P. splendens* and *P. sideropterus* by classifying the latter as an aberration of the former. Dissected specimens of *P. sideropterus* were first reported in SMETANA (1955), who did not see any difference in the structure of the aedeagus between *sideropterus* and *splendens* but suggested subspecies status for *sideropterus* based on its allopatric distribution. SMETANA (1955) mistakenly assumed that KOLENATI (1846) described *P. sideropterus* as a species of its own. SMETANA (1958, 1959), consistent with his earlier decision, listed *sideropterus* as a subspecies of *P. splendens*. COIFFAIT (1967) also included *sideropterus* as a subspecies of *P. splendens*, but in a later work he (COIFFAIT, 1974) again listed *sideropterus* as a variety of *P. splendens*. SCHILLHAMMER (2000) acknowledged the volatile status of *sideropterus* and, similarly to SMETANA (1955, 1958, 1959), classified it as a subspecies.

Material and methods

Specimen acquisition, georeferencing, and mapping

Specimens for this study came from the collections of the Natural History Museum of Denmark (NHMD), the Natural History Museum of Vienna (NHMW), the Museum of Natural History at Berlin (ZMHB), the National Museum of Natural History in Paris (MNHN), the Basel Museum of Natural History (NHMB) and the Zoological Institute, Russian Academy of Science, St. Petersburg (ZISP). Species distributions were mapped based on the specimen label data. Because of the great abundance of material of *P. splendens*, only selected specimens were mapped, while for the more limited material of *P. sideropterus* all available specimens were georeferenced and included on the map. The dataset of the specimens examined for this study is available from Supplementary File 1. Further distribution data for both taxa were collected from the literature (FAUVEL 1878; KOCHER 1958; TÓTH 1984; BABENKO 1989; VESELOVA & RYVKIN 1991; NIKITSKY et al. 1996; SCHILLHAMMER 2000; GORESLAVETS et al. 2002; DEDYUKHIN et al. 2005; GORESLAVETS 2010; STAN 2013; BABENKO et al. 2014; KADYROV et al. 2014; SEMENOV et al. 2015; SEMIONENKOV et al. 2015; MATĚJČEK et al. 2018; ASSING & SCHÜLKE 2019; PSAREV et al. 2020; ÖZDEMİR 2021) and from the GBIF occurrence dataset (GBIF.org, GBIF Occurrence Download <https://doi.org/10.15468/dl.5jnn2a>). For GBIF, data were exported using the built-in download function on the website, and only observations with available coordinates were used. Coordinates were then extracted from the CSV file and transferred to a text file. All available data from GBIF and the above-mentioned literature resources were kept separately as unconfirmed literature reference data.

The dataset with the specimen-, literature- and GBIF-based coordinates was processed with SimpleMappr (SHORTHOUSE 2010) to create the distribution map for *P. splendens* and *P. sideropterus*. Here, we made a distinction between confirmed specimens that we physically examined and whose labels we transcribed for this study and unconfirmed specimens with data gathered from GBIF and the literature.

Morphological investigation

Selected individuals (five ♂♂ and three ♀♀ of *P. sideropterus*; five ♂♂ and three ♀♀ of *P. splendens*, including the smallest and largest specimens, color variations and representatives best covering the distribution range) were dissected using forceps and a size 0 insect pin with a bent tip to dislodge the terminalia. The dissected terminalia were suspended in a water-based lubricant on a microscope slide for photography.

Stacked images were produced using a Canon EOS 5D Mark III digital camera fitted with a Canon MP-E65 f2.8 1–5 × macro lens. Images were imported to Zerene Stacker v1.04 (Zerene Systems, Richland, WA, USA) and stacked using the Pmax function. Pictures were edited in Photoshop v24.6 (Adobe Inc., San Jose, CA, USA) to remove dust and other impurities on photographed specimens. Figures were created and edited in Illustrator v27.7 (Adobe Inc., San Jose, CA, USA).

An overview of the label data of the dissected specimens used for the morphological figures can be found at Supplementary File 1.

DNA extraction and PCR

DNA extractions were done using the EZNA DNA Tissue kit (Omega Bio-tek, Norcross, GA, USA), following the product protocol for tissue with a prolonged lysis time (24 hours). For non-destructive extraction, the entire specimen was soaked in a lysis buffer and immediately transferred to 96% ethanol after lysis. After DNA extraction, the physical vouchers were glued on card and mounted on pins, with the terminalia segments and aedeagus fixed with water-soluble glue on the same card. See Supplementary File 1 for specimens included in the figures.

For *COI*, the PCR reaction consisted of 1 µl of DNA extract, 4 µl of 5× HOT FIREPol Blend Master Mix Ready to Load With 10 mM MgCl₂ (Solis BioDyne), 1 µl of each primer at 0.5 µM and 18 µl distilled water. Primers and the specific PCR cycles were as follows:

COI (658bp) (LCO1490+HCO2198): 15'94 °C – 5x (30s 94 °C – 40s 47 °C – 1'72 °C) – 30x (30s 94 °C – 40s 52 °C – 1'72 °C) – 7'72 °C.
sCOI (407bp) (MLepF1+LepR1): 15'95 °C – 5x (30s 94 °C – 40s 45 °C – 1'72 °C) – 38x (30s 94 °C – 40s 51 °C – 1'72 °C) – 10'72 °C.

Two different strategies were used to obtain DNA sequences. These were Sanger sequencing and Nanopore sequencing using a Flongle flow cell on the MinION, respectively.

Forward and reverse Sanger sequencing and purification of target *COI* amplicons was done by Macrogen (Amsterdam, The Netherlands). The forward and reverse raw sequences were aligned to a reference *P. splendens* barcode (GenBank Accession: KJ966992) in Geneious Prime (v2023.1) (<https://www.geneious.com>) and edited for obvious alignment errors.

MinION-based sequencing of the PCR amplified extractions containing the short *COI* (*sCOI*) loci (see Supplementary File 1 for specimen list) was done by Flongle Sequencing (SRIVATHSAN et al. 2021). During the previous PCR step, tagged primers were used on samples intended for Flongle Sequencing,

enabling differentiation between samples. All included material from the *sCOI* PCR was pooled together, followed by a thorough Clean-up, DNA repair, and end-prep step. This was designed to remove unwanted primer sequences and to ensure all DNA fragments were of the same length and free of any artifacts introduced by the polymerase during PCR. The Flongle flow cell was placed in the Flongle adapter connected to the MinION, and then loaded with the pooled and cleaned DNA material. After running for 24 hours, the output data were made available after transfer from the MinION to a computer with Filezilla (<https://filezilla-project.org/>, v3.65.0-rc1). Basecalling was done using Guppy (https://timkahlke.github.io/LongRead_tutorials/BS_G.html) on the extracted file output to interpret the ionic signal into base pairs. The basecalled output sequences were then demultiplexed using ONTbarcode (v0.1.9b, and v0.1.11c), sorting out the sequences based on the combination of tagged primers (SRIVATHSAN et al. 2021). The final output file was uploaded to Geneious Prime (v2023.1) for alignment and reference barcode mapping using the same reference as above.

The procedure for the nested PCR of *Wg* was similar to that for *COI*, except that two runs that were done with the second nested *Wg* using 1 µl of DNA product from the first initial *Wg*. Primers and specific PCR cycles for the initial *Wg* and nested *Wg* as follows:

Wg initial (Wg550F+WgABRZ): 15°94 °C – 35x (30s 94 °C – 30s 59 °C – 1°72 °C) – 5°72 °C.

If this initial PCR failed to show a band on the gel electrophoresis, another reaction was set up using the initial PCR product as DNA template with a new set of internally nested primers using the following conditions:

Wg nested (Wg578F + WgABR [464 bp]): 15°94 °C – 35x (30s 94 °C – 30s 59 °C – 3°72 °C) – 5°72 °C.

Forward and reverse Sanger sequencing and purification of target *Wg* amplicons was done by Macrogen (Amsterdam, The Netherlands). The forward and reverse raw sequences were aligned to a reference *P. splendens* barcode (GenBank Accession: GU377489).

Phylogenetic analyses

All generated *COI* sequences for *P. splendens* and *P. sideropterus* were compiled into an ingroup dataset that also included all publicly available *COI* data on these taxa from BOLD and GenBank (RATNASINGHAM & HEBERT 2007). To define an outgroup, a different dataset containing all available *Philonthus COI* data from the BOLD database was used (dataset available from Supplementary File 2). This dataset was run using a Maximum Likelihood (ML) phylogenetic analysis on the IQ-TREE web server (TRIFINOPOULOS et al. 2016). The resulting ML tree was visualized in FigTree (v1.4.4) (RAMBAUT 2018). Based on this, *Philonthus decorus* (Gravenhorst, 1802), *P. politus* (Linnaeus, 1758), *P. addendus* Sharp, 1867, and *P. nitidus* (Fabricius, 1787) were chosen as outgroups for our following analyses. All available barcodes from the mentioned species were included in the final dataset. The entire dataset containing both out- and ingroup was aligned using the MAFFT Multiple Alignment (v1.5.0) plugin in Geneious Prime (KATO et al. 2002) (dataset available from Supplementary File 3).

Two separate phylogenetic analyses, Maximum Likelihood (ML) and Bayesian Inference (BI), were applied to this dataset to explore the status of *P. splendens* and *P. sideropterus*.

The ML analysis was performed using the IQ-TREE web server with default settings, except that partitioning was added by codon position and an additional test of support was carried out with Ultrafast Bootstrap (UFB) (run for 10,000 iterations).

The BI dataset was initially run in PartitionFinder2 (v2.1.1) (LANFEAR et al. 2017), with partitioning by codon position. The most suitable substitution model was searched under the Bayesian Information Criterion. The following settings were used: for model choice ‘Bayesian’, for branch lengths ‘unlinked’, and for search choice ‘greedy’. Using the model found (GTR+I), the BI analysis was performed using MrBayes (v3.2.7) (RONQUIST et al. 2012) with default settings, running 30 million generations.

Convergence was examined by visualizing output files in Tracer (v1.6.0) (RAMBAUT et al. 2018) and by checking the Potential Scale Reduction Factor (PSRF). Support values are defined as follows: Ultrafast Bootstrap (UFB), Shimodaira–Hasegawa-like approximate likelihood ratio test (SH-aLRT), and posterior probability (PP). For each analysis, we considered posterior probability values (PP) ≥ 0.90, SH-aLRT ≥ 80, and UFB ≥ 90 to indicate clade support, respectively. ML and BI trees were visualized using FigTree (v1.4.4), where the phylogenetic trees were rerooted with *P. nitidus* and *P. politus* as the outgroup. *Wg* was analyzed similarly to *COI*. The *Wg* dataset comprised all newly generated and publicly available *Wg* sequences from GenBank (BENSON et al. 2013). For the outgroup, one *P. nitidus* specimen (GenBank Accession: KY009483) was used. The outgroup was chosen as the species most closely related to *P. splendens*, based on the same outgroup finding as for *COI*, with an online available *Wg* barcode. The SYM substitution model was found to best fit the *Wg* dataset and was implemented for all Bayesian analyses.

Haplotype network and species delimitation analysis

Popart 1.7 (LEIGH TAB & BRYANT, 2015) was used to build a multiple integer neighbor-joining (IntNJ) haplotype network using the same approach as in HANSEN & JENKINS SHAW (2023). In addition, ABGD, ASAP, and bPTP species delimitation analyses were conducted.

ASAP (Assemble Species by Automatic Partitioning) (PUILLANDRE et al. 2021) was run through the web portal at <https://bioinfo.mnhn.fr/abi/public/asap/>. In the analysis, both the Jukes-Cantor (JC69) and Kimura (K80 with ts/tv set to 2) models for substitutions were used.

ABGD (Automatic Barcode Gap Discovery) (PUILLANDRE et al. 2012) was done through the same web portal at <https://bioinfo.mnhn.fr/abi/public/abgd/abgdweb.html>, using default settings (Pmin = 0.001; Pmax 0.1; Steps 10; and X = 1.5).

A species delimitation analysis using both the ML and BI trees from the phylogenetic analyses was performed using the web-supported bPTP (bayesian Poisson Tree Processes) model (ZHANG et al. 2013). Both the unrooted consensus trees of ML (bPTP-ML) and BI (bPTP-BI) were analyzed using default settings (MCMC generations: 100,000; thinning: 100; burn-in: 0.1). Convergence was checked for all output files.

Primary data depository

Label data and DNA-voucher numbers for all specimens included in this study can be found in Supplementary File 1.

Results

Geographical distribution and bionomics

As clearly shown in Fig. 3, the wide distribution range of *P. splendens* extends from Western Europe to Cen-

tral Siberia. The range of *P. sideropterus* is much more restricted, confined to the Caucasus and Northern Turkey, and well separated from the range of *P. splendens* by the drier Western Turkey in the East and by the Ciscaucasian open plains in the North. An outlier record from the southern part of Turkey (Gaziantep, Dilok) is based on a single old specimen (no date, but from the collection of EDUARD EPPELSHEIM [1837–1896]), which we consider a mislabeling as we have yet to see other material from the area, which usually houses another fauna. The distribution of *P. splendens* occurs at lower altitudes in more northern areas, while it is mostly found in mountainous areas in the southern part of its range, for instance in the European Alps and Atlas Mountains of North Africa. Here, also a few outlier records were found in the literature, with mentions of findings in Middle Asia (KADYROV et al. 2014), North Korea (SCHILLHAMMER 2000), and Northeast China (Li & Chen 1993). Neither of these records could be confirmed by us, and we believe they could represent misidentifications, mislabelings, or sporadic introductions. *Philonthus splendens* seems to be confined to the nemoral forests of Eurasia, occurring mainly in or around dung. Noteworthy is the absence of records from the plains of West Siberia, but the notable presence of the species in the more montane south-eastern part of that region. Based on our personal collecting experience and records with sufficient bionomic data, *P. sideropterus* is always found in the humid elevated mountain areas, mainly in or around dung, in the zones with temperate forest or in the subalpine belt with bushy vegetation. Interestingly, in the extensive summary by SALNITSKA et al. (2022) of the faunistic literature for the open plains of South European Russia, *P. splendens* is also reported as absent there, meaning that the gap

between the distributions of *P. splendens* and *P. sideropterus* in the Ciscaucasian plain is real and not an artifact of poor sampling.

Morphology

As repeatedly noted by earlier authors, *P. splendens* and *P. sideropterus* differ from each other in the coloration of the elytra. All specimens from the distribution area of *Philonthus splendens* have a metallic elytra coloration ranging from bright brass to a deep dark brown, while all Caucasian specimens, i.e., *P. sideropterus*, have metallic-colored elytra with a blue hue. The blue hue ranges from bright ocean blue to a deep, almost blackish blue. The only exception was a single specimen of *P. sideropterus* from Gümüşhane (NE Turkey) with reddish non-metallic brown elytra (Fig. 4A).

SCHILLHAMMER (2000) showed a slight difference between *P. splendens* and *P. sideropterus* in the structure of the aedeagus: in the shape of the median lobe and position of the sensory peg setae on the paramere (line drawings in Fig. 4C). However, this difference does not hold when more specimens are compared (photos in Fig. 4C). Investigation of the female 10th tergite also showed no difference between the investigated taxa (Fig. 4B).

Phylogenetic and species delimitation analyses

ML and BI trees support *P. sideropterus* and *P. splendens* as sister clades with respective support values of UFB=99.2/87.9, SH-aLRT=100/89, and PP=1/0.86 and support for the monophyletic ingroup as high as UFB=99.8, SH-aLRT=100, and PP=1 (Fig. 5).

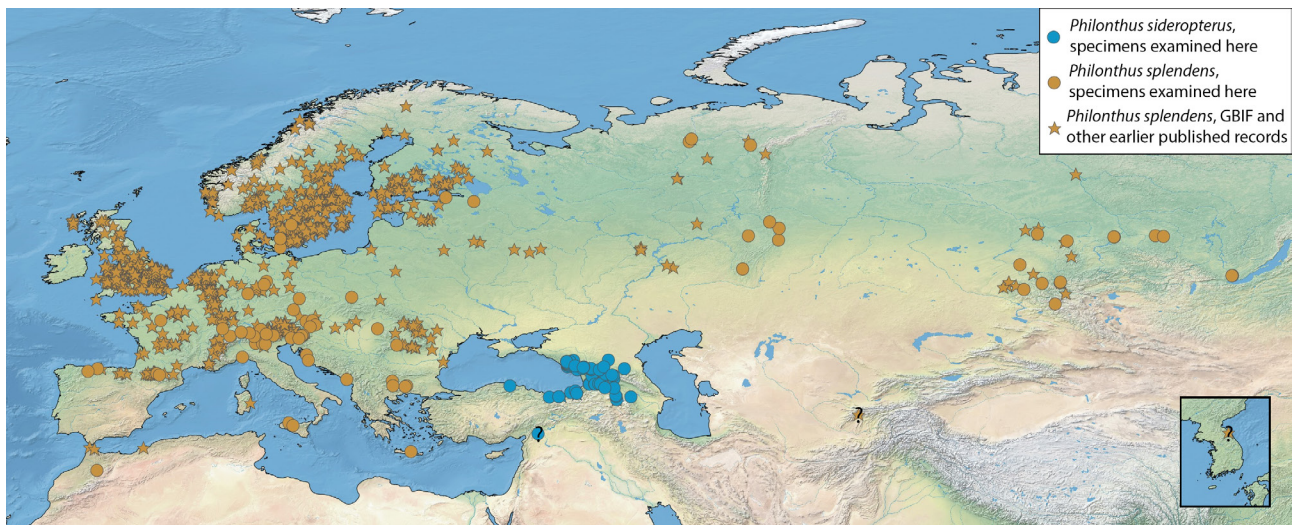

Fig. 3. Distribution map of *P. sideropterus* (blue) and *P. splendens* (brown). Localities based on examined specimens are shown by circles; localities based on records in GBIF or the literature are shown by stars.

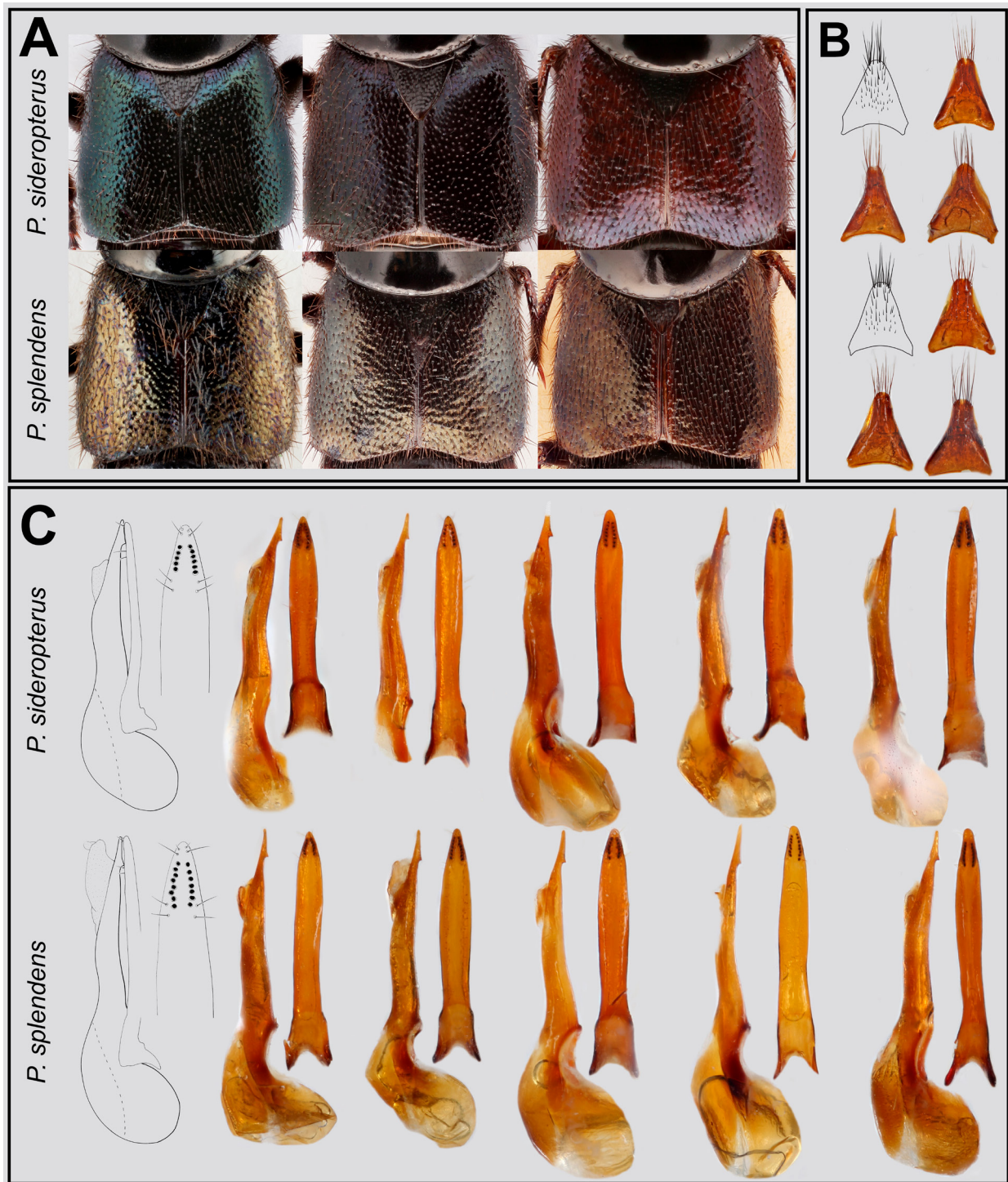

Fig. 4. Morphological variation in *P. splendens* and *P. sideropterus*. **A.** Variation in elytra coloration ranging from dark to clear metallic colors for *P. sideropterus* (blue) and *P. splendens* (brass); includes rare reddish brown color morphs found in both taxa. **B.** Morphological variation in 10th tergite of female *P. sideropterus* (top four) and *P. splendens* (bottom four). **C.** Morphological variation in the median lobe and paramere of the aedeagus in *P. splendens* and *P. sideropterus* (localities and other information about every illustrated specimen can be found in the supplementary dataset for the material examined, where illustrated specimens are flagged in the “Figure” column, available in Supplementary File 1. Line drawings of median lobe (in lateral view) and paramere (in dorsal view, i.e., underside facing median lobe) provided by HARALD SCHILLHAMMER show previously hypothesized shape of the aedeagus for both taxa.

All species delimitation methods, ASAP, ABGD, and bPTP, showed congruent results supporting species-level differentiation between *P. splendens* and *P. sideropterus* (Fig. 5).

The haplotype network analysis (Fig. 5) shows the significant molecular distance between *P. splendens* and *P. sideropterus*. Nucleotide differences between *P. splendens* and *P. sideropterus* ranged from 16 to 19. A much lower level of intraspecific divergence was observed for both *P. splendens* and *P. sideropterus*: 1–4 and 1–2 nucleotides, respectively.

For *Wg*, we experienced poor quality of sequencing, resulting in aligned forward and reverse reads of very variable lengths (204–438bp instead of the targeted 464). The low amplification success of this marker could be related to many of our extracts being from museum specimens, from which nuclear genes are generally more difficult to recover. Another potential issue could be low specificity of the used primers for our target taxa, as these were general insect primers and not modified to fit our target. We found no difference in *Wg* between the two species in both the BI and ML analyses (Supplementary Fig. 1).

Discussion

Differences and similarities between *P. splendens* and *P. sideropterus*

Our study supports the previously used cyan-blue color of the elytra as a primary diagnostic character separating *P. sideropterus* from *P. splendens*. Even though in *Philonthus*, as noted by SCHILLHAMMER (2000), this is usually an unreliable character state due to the fact that “metallic colors, particularly of the elytra, display a wide spectrum of tinges”, it works well in the case of *P. splendens* and *P. sideropterus*. Although the elytra of *P. sideropterus* and *P. splendens* have varying tinges, the color morphs of *P. sideropterus* with bright cyan elytra are very easily distinguished from *P. splendens* with clear brass elytra (Fig. 4A). The darker specimens of both taxa are more difficult to tell apart unless they are viewed under intense light, such as a camera flash, and/or treated with a photo-editing software to enhance light and contrast. Although such darker-colored specimens would make identification difficult, they are not common and are geographically separated (Fig. 4A).

This difference in elytra coloration was supported by the *COI* barcode data, which showed two distinct species in all delimitation analyses, with a 4.3% distance between the two species clusters. This distance is similar to the distance displayed between other species of Staphylininae, e.g., *Cafius* Stephens, 1829 (YOO et al. 2022), *Quedius* Stephens, 1829 (HANSEN et al. 2022), and *Quedionuchus*

Sharp, 1884 (BRUNKE et al. 2020). During this investigation, we found that very rare (ca. 1 in 200 specimens) brown and reddish morphotypes are present in both *P. splendens* and *P. sideropterus* (Fig. 4A). Presumably, these color morphs are late teneral stages (the elytra in rove beetles obtain full coloration later than the rest of the body, and other body parts may appear less dark in those specimens) or are indeed rare color morphs. These specimens with brown or reddish elytra clustered with their respective species in all molecular analyses and are found randomly across the distributions of both taxa. Moreover, this reddish tinge was found to differ between *P. sideropterus* and *P. splendens*: its color in *P. splendens* is akin to that in *P. nitidus*, although slightly darker, whereas in *P. sideropterus* it is dark brown.

Investigation of the aedeagi of *P. splendens* and *P. sideropterus* showed a slight difference in the shape of the median lobe and the number of peg setae on the paramere. Both traits do not hold for all specimens and show an overlap (Fig. 4C). However, the combination of a more distal position of the apical tooth of the median lobe and a lower number of peg setae on the paramere (<14) would indicate *P. sideropterus* in most cases. Females of both taxa can be separated by the coloration of the elytra only, as there is no other detectable difference including sternite 10 (Fig. 4B).

We found no differences in the nuclear wingless gene (*Wg*) for this species pair (Supplementary Fig. 1). Although *Wg* is occasionally used in species-level delimitation (TOUSSAINT et al. 2015; MUÑOZ-TOBAR & CATERINO 2020), it is more successfully used to infer phylogenetic relationships at the subtribal or even higher level for Staphylininae (BRUNKE et al. 2016). For the future, partial *CAD* (carbamoyl-phosphate synthetase 2, aspartate transcarbamylase, and dihydroorotase), a nuclear gene that has proven to work for Coleoptera as a species-delimiting marker (GORRING & COGNATO 2023), can be tried for the *P. splendens* complex.

Historical biogeography

Distributional and ecological evidence supports *P. sideropterus* and *P. splendens* as separate species that likely originated as a result of the boreo-montane disjunction (VUKOJIĆ et al. 2014) of the ancestral species' range. One hypothesis would be that the cooler climate during the Pliocene (5.30–2.58 Ma) (BURKE et al. 2018; BERIDZE et al. 2023; HANSEN et al. 2023) enabled populations of a common ancestor of *P. splendens* and *P. sideropterus* to expand their range south to Asia Minor and the Caucasus. Presumably, this expansion occurred via the more forested areas of Eastern Europe, especially along the north-south oriented, large forested river valleys or via “mountain hopping” through the Alps, Balkans, and mountainous

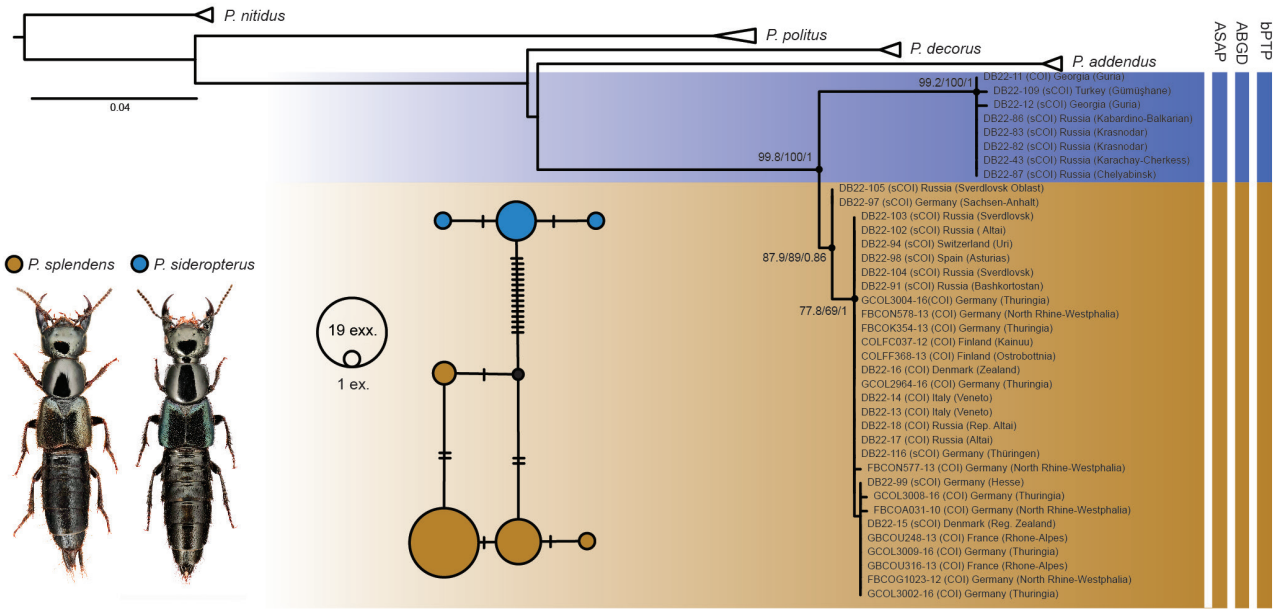

Fig. 5. An integer neighbor-joining haplotype network (center) and consensus phylogenetic tree based on Bayesian and Maximum Likelihood analyses of the *COI* barcode, with support values. Support values at each node are shown in the following order: UFB, SH-aLRT, PP. Bars with gaps on the right indicate the most probable clustering of three species delimitation methods. The size of the circles in the haplotype network is proportional to the number of specimens in the clusters; vertical bars between the clusters represent nucleotide differences.

areas of Turkey, finally reaching the Greater Caucasus via the Lesser Caucasus. Regardless of the initial southwards expansion routes of a temperate species during the cooler period, subsequent rises in temperatures and increasing continentality possibly led to the isolation of the southeasternmost populations at the cooler and more humid higher elevations of the Caucasus and Northern Turkey, where they evolved into a separate species, *P. sideropterus*. Presumably, the original range of the lineage which is now *P. splendens* was also fractured between the more northern populations and the more southern one(s) retracting to higher elevations in the central and southern European mountains or even North Africa, but their isolation apparently was not as significant. More recent Quaternary climate fluctuations may also have enabled populations from North Africa, the Alps, and the Balkans to mix with more northern Euro-Siberian populations.

Conclusion and taxonomy

We used an integrative taxonomic approach, namely three lines of evidence such as molecular species delimitation, morphology, and biogeography, to resolve the ambiguous taxonomic status of *P. sideropterus*, previously treated as either a variety or a subspecies of *P. splendens*. Molecularly, *P. sideropterus* and *P. splendens* are

clearly supported as separate species by *COI* barcode data but not by the nuclear *Wg* marker, which gave an inconclusive answer to the same question largely due to a shortage of data related to practical difficulties in obtaining this marker from museum specimens. The earlier noted external morphological difference in the coloration of elytra between *P. sideropterus* and *P. splendens* is here confirmed as stable and easy to see in the great majority of specimens. The earlier stated subtle genitalic differences between males of both taxa are here not confirmed because of the newly revealed intermediate forms that, however, do not show any geographic pattern. The distributions of both taxa are clarified and shown to be confined to areas of sufficient humidity; they are clearly allopatric and well separated from each other by a large drier area without suitable habitats for either taxon. The molecular distance (clear in *COI*), morphological differences (clear in the elytral coloration), and wide geographic gap between *P. splendens* and *P. sideropterus* indicate that they are well established and well diagnosable allopatric sister lineages that lack gene flow. Even without visible differences between their male genitalia, they do not match the definition of subspecies as emerging allopatric lineages that did not completely lose genetic connectivity (BRABY et al. 2012). Although, recently, DUFRESNES et al. (2023, 2024) and LUKHTANOV (2024) removed the demand of genetic connectivity as a criterion for subspecies and encouraged to

use this category in taxonomy to accommodate closely related phylogeographic lineages, here we explicitly abandon the previous very ambiguous treatment of *P. sideropterus* as a subspecies (SMETANA 1955, 1958, 1959; COIFFAIT 1967; SCHILLHAMMER 2000) or a variety (KOLENATI 1846; HOCHHUTH 1849; KRAATZ 1857; COIFFAIT 1974) of *P. splendens*. Instead, we raise the status of *Philonthus sideropterus* Kolenati, 1846, **sp. propr.** to species level, which in fact was already suspected by KOLENATI (1846) nearly two centuries ago.

Lectotype designation

The original description of *Staphylinus splendens* (FABRICIUS 1793) only states that the species is known from Germany. At the Zoological Museum in Kiel, where the historical collection of Coleoptera of FABRICIUS is kept, there is only one handwritten Fabrician bottom label (“splendens”) and two specimens associated with that label, to be considered as syntypes. FABRICIUS’s handwritten label “splendens” can be seen in (Supplementary Fig. 2A). Only one of the syntypes (Supplementary Fig. 2A) matches the original description and is conspecific with *P. splendens* in the current understanding, while the other is *Ocyopus picipennis* (Fabricius, 1793) (Supplementary Fig. 2B). To ensure nomenclatural stability, we here designate the former specimen as a lectotype of *P. splendens* and have labeled it accordingly (Supplementary Fig. 2A), while the latter specimen becomes a paralectotype. Interestingly, the same lectotype designation was apparently planned decades ago by DIDIER DRUGMAND (Belgium), who attached labels to that effect (Supplementary Fig. 2A), but it was never formally published. As far as *P. sideropterus* is concerned, so far we were unable to locate the type material when we tried at the Zoological Institute of the Russian Academy of Science in St. Petersburg or in several European museums.

Acknowledgements

We sincerely thank MICHAEL KUHLMANN at Kiel Zoological Museum (Germany) for providing photos of the syntypes of *P. splendens* and DIRK AHRENS at Alexander Koenig Museum in Bonn (Germany) for his attempt to locate the type material of *P. sideropterus*. We thank HARALD SCHILLHAMMER at NHMW, ANTOINE MANTILLERI at MHNP, BERND JAEGER at ZMHB, and MATTHIAS BORER at NHMB for access to the collections under their care. LG acknowledges a Bøje Benzon Foundation grant to conduct fieldwork in Middle Asia, aimed in particular at checking ambiguous records of *P. splendens* from that area. AKH acknowledges the Carlsberg Foundation for its continuous support of his postdoc activities through the project “Next Generation Taxonomy”. We would like to send a big thanks to the 15. June Foundation and Aage V. Jensen Foundation for support of the project ‘Lort er det nye sort: Biller i godning’, which made the development of this manuscript possible. Lastly, help-

ful comments by HARALD SCHILLHAMMER and a second (anonymous) reviewer led to improvements of an earlier version of this manuscript.

References

- ASSING, V. & SCHÜLKE, M. (2019): The Staphylinidae of Armenia and Nagorno-Karabakh (Coleoptera). – *Beiträge zur Entomologie = Contributions to Entomology* **69**: 91–173. <https://doi.org/10.21248/contrib.entomol.69.1.091-173>
- BABENKO, A. S. (1989): Rove beetles of the tribe Philonthini (Coleoptera, Staphylinidae) of the south-east of Western Siberia. – *Entomologicheskoe Obozrenie* **68**: 313–321.
- BABENKO, A., TEMNIKOVA, I. & BOKOVA, U. (2014): Soil fauna as an indicator of disturbed forest areas in West Siberian industrial regions (the Kuznetsky Alatau case study). – *International Journal of Environmental Studies* **71**: 671–677. <https://doi.org/10.1080/00207233.2014.945690>
- BENSON, D. A., CAVANAUGH, M., CLARK, K., KARASCH-MIZRACHI, I., LIPMAN, D. J., OSTELL, J. & SAYERS, E. W. (2013): GenBank. – *Nucleic Acids Research* **41**: 36–42. <https://doi.org/10.1093/nar/gks1195>
- BERIDZE, B., SEKIEWICZ, K., WALAS, Ł., THOMAS, P. A., DANIELA, I., KVARTSKHAVA, G., FAZALIYEV, V., BRUCH, A. A. & DERING, M. (2023): Evolutionary history of *Castanea sativa* Mill. in the Caucasus driven by Middle and Late Pleistocene paleoenvironmental changes. <https://doi.org/10.1101/2023.01.11.523563>
- BERNHAEUER, M. & SCHUBERT, K. (1914): Staphylinidae IV. – In: SCHENKLING, S. (ed.): *Coleopterorum Catalogus*. 5th edition, pp. 289–408; Berlin (W. Junk).
- BRABY, M. F., EASTWOOD, R. & MURRAY, N. (2012): The subspecies concept in butterflies: has its application in taxonomy and conservation biology outlived its usefulness? – *Biological Journal of the Linnean Society* **106**: 699–716. <https://doi.org/10.1111/j.1095-8312.2012.01909.x>
- BRUNKE, A. J., CHATZIMANOLIS, S., SCHILLHAMMER, H. & SOLODOVNIKOV, A. (2016): Early evolution of the hyperdiverse rove beetle tribe Staphylinini (Coleoptera: Staphylinidae: Staphylininae) and a revision of its higher classification. – *Cladistics* **32**: 427–451. <https://doi.org/10.1111/cla.12139>
- BRUNKE, A. J., SALNITSKA, M., HANSEN, A. K., ZMUDZINSKA, A., SMETANA, A., BUFFAM, J. & SOLODOVNIKOV, A. (2020): Are subcortical rove beetles truly Holarctic? An integrative taxonomic revision of north temperate *Quedionuchus* (Coleoptera: Staphylinidae: Staphylininae). – *Organisms Diversity & Evolution* **20**: 77–116. <https://doi.org/10.1007/s13127-019-00422-2>
- BURKE, K. D., WILLIAMS, J. W., CHANDLER, M. A., HAYWOOD, A. M., LUNT, D. J. & OTTO-BLIESNER, B. L. (2018): Pliocene and Eocene provide best analogs for near-future climates. – *Proceedings of the National Academy of Sciences of the United States of America* **115**: 13288–13293. <https://doi.org/10.1073/pnas.1809600115>
- CHALADZE, G., OTTO, S. & TRAMP, S. (2014): A spider diversity model for the Caucasus Ecoregion. – *Journal of Insect Conservation* **18**: 407–416. <https://doi.org/10.1007/s10841-014-9649-1>
- CHANI-POSSE, M. (2010): Revision of the southern South American species of *Philonthus* Stephens (Coleoptera: Staphylinidae). – *Zootaxa* **2595** (1): 1–70. <https://doi.org/10.11646/zootaxa.2595.1.1>

- COIFFAIT, H. (1967): Tableau de détermination des *Philonthus* de la région Paléarctique occidentale (Col. Staphylinidae). – *Annales de la Société Entomologique de France* **3**: 381–450.
- COIFFAIT, H. (1974): Coléoptères staphylinides de la région paléarctique occidentale II. Sous famille Staphilininae, Tribus Philonthini et Staphylinini. – *Nouvelle Revue d'Entomologie. Supplément* **4**: 1–593.
- DEDYUKHIN, S. V., NIKITSKY, N. B. & SEMENOV, V. B. (2005): Checklist of beetles (Insecta, Coleoptera) of the Udmurt Republic. – *Euroasian Entomological Journal* **4**: 293–315.
- DUFRESNES, C., POYARKOV, N., JABLONSKI, D. (2023): Acknowledging more biodiversity without more species. – *Proceedings of the National Academy of Science* **120**: e2302424120. <https://doi.org/10.1073/pnas.2302424120>
- DUFRESNES, C., POYARKOV, N., JABLONSKI, D. (2024): Reply to Lukhtanov: Polytypic species: Old wine in a new bottle. – *Proceedings of the National Academy of Science* **121**: e2321819121. <https://doi.org/10.1073/pnas.2321819121>
- FABRICIUS, J. C. (1793): *Entomologiae Systematicae, emendatae et auctae*. – Secundum classes, ordines, genera, species adjectis synonymis, locis, observationibus, descriptionibus **1**, 538 pp; Hafniae (Christian Gottlob Proft). <https://doi.org/10.5962/bhl.title.125869>
- FAUVEL, A. (1878): Lers staphylinides de l'Afrique boréale. – *Bulletin de la Société Societe Linneenne de Normandie* (3) **2**: 83–162.
- GAGNIDZE, R., GVINIASHVILI, T., SHETEKAURI, S. & MARGALITADZE, N. (2002): Endemic genera of the Caucasian flora. – *Feddes Repertorium* **113**: 616–630. <https://doi.org/10.1002/fedr.200290009>
- GANGLBAUER, L. (1895): Die Käfer von Mitteleuropa. Die Käfer der österreichisch-ungarischen Monarchie, Deutschlands, der Schweiz, sowie des französischen und italienischen Alpengebieten. 2. Familienreihe Staphyloidea. Theil I. Staphylinidae, Pselaphidae, 881 pp.; Vienna (Carl Gerold's Sohn). <https://doi.org/10.1002/mmnd.48018950245>
- GEBREMESKEL, A., SALNITSKA, M., KRIVOSHEEVA, V. & SOLODOVNIKOV, A. (2023): Micro-endemism pattern and Wolbachia infection of *Quedius obliquiseriatus* (Coleoptera, Staphylinidae), a montane rove beetle endemic of the North-Western Caucasus. – *Alpine Entomology* **7**: 153–166. <https://doi.org/10.3897/alpento.7.111214>
- GORESLAVETS, I. N., SOLODOVNIKOV, A., GILDENKOV, M. & GREBENNIKOV, K. (2002): Rove beetles (Coleoptera, Staphylinidae) of Samara province: subfamilies Omaliinae, Proteininae, Tachyporinae, Habrocerinae, Oxytelinae, Oxyporinae, Steninae, Euaesthetinae, Paederinae and Staphylininae. – *Entomological Review* **81**: 343–355.
- GORESLAVETS, I. N. (2010): Materials to the fauna of rove beetles (Coleoptera, Staphylinidae) of Zhiguli Biosphere Reserve. – *Samarskaja Luka: problems of regional and global ecology* **19**: 98–121.
- GORRING, P. S. & COGNATO, A. I. (2023): The case for a nuclear barcode: using the CAD CPS region for species and genus level discrimination in beetles. – *Diversity* **15**: 847. <https://doi.org/10.3390/d15070847>
- HANSEN, A. K. & JENKINS SHAW, J. (2023): High altitude morphology of the widespread *Lobrathium multipunctum* (Gravenhorst, 1802) (Coleoptera, Staphylinidae, Paederinae) revealed by DNA-barcoding. – *Contributions to Entomology* **73**: 1–8. <https://doi.org/10.3897/contrib.entomol.73.e102511>
- HANSEN, A. K., BRUNKE, A. J., SIMONSEN, T. & SOLODOVNIKOV, A. (2022): Revision of *Quedius sensu stricto* (Coleoptera: Staphylinidae). – *Acta Entomologica Musei Nationalis Pragae* **62**: 225–299. <https://doi.org/10.37520/aemnp.2022.017>
- HANSEN, A. K., BRUNKE, A. J., THOMSEN, P. F., SIMONSEN, T. J. & SOLODOVNIKOV, A. (2023): Formation of the Holarctic Fauna: Dated molecular phylogenetic and biogeographic insights from the *Quedius*-lineage of Ground-Dwelling Rove Beetles (Coleoptera, Staphylinidae). – *Molecular Phylogenetics and Evolution* **182**: 107749. <https://doi.org/10.1016/j.ympev.2023.107749>
- HOCHHUTH, J. H. (1849): Die Staphylinen-Fauna des Kaukasus und Transkaukasiens. – *Bulletin de la Société Impériale des Naturalistes de Moscou* **22**: 18–214.
- HRIVNIAK, L., SROKA, P., BOJKOVÁ, J., GODUNKO, R. J., SOLDÁN, T. & STANICZEK, A. H. (2020): The impact of Miocene orogeny for the diversification of Caucasian *Epeorus (Caucasiron)* mayflies (Ephemeroptera: Heptageniidae). – *Molecular Phylogenetics and Evolution* **146**: 106735. <https://doi.org/10.1016/j.ympev.2020.106735>
- HROMÁDKA, L. (2008): Revision of Afrotropical species of the *Philonthus abyssinus* species group (Coleoptera: Staphylinidae: Philonthina). – *Acta entomologica Musei Nationalis Pragae* **48**: 37–50.
- HROMÁDKA, L. (2012): Revision of the Afrotropical species of the *Philonthus longicornis* species group (Coleoptera: Staphylinidae: Staphylininae). – *Klapalekiana* **48**: 75–120.
- JUSTESEN, M. J., HANSEN, A. K., KNÍZEK, M., LINDELOW, Å., SOLODOVNIKOV, A. & RAVN, H. P. (2023): Taxonomic reappraisal of the European fauna of the bark beetle genus *Cryphalus* (Coleoptera, Curculionidae, Scolytinae). – *ZooKeys* **1179**: 63–105. <https://doi.org/10.3897/zookeys.1179.101388>
- KADYROV, A. X., YAKUBOVA, D. S. & DADABAEV, X. R. (2014): Systematic list of family Staphylinidae (Coleoptera) of the slope Southern Gissar Mountains. – *News of the Academy of Sciences of the Republic of Tajikistan. Department of Biological and Medical Sciences* **2**: 46–50.
- KATOH, K., MISAWA, K., KUMA, K. I. & MIYATA, T. (2002): MAFFT: A novel method for rapid multiple sequence alignment based on fast Fourier transform. – *Nucleic Acids Research* **30**: 3059–3066. <https://doi.org/10.1093/nar/gkf436>
- KOCHER, L. (1958): *Catalogue commenté des Coléoptères du Maroc II*, 144 pp; Rabat (Société des Sciences Naturelles et Physiques du Maroc avec une Subvention du Ministère de l'Instruction publique et des Beaux-Arts).
- KOLENATI, F. A. (1846): *Meletemata entomologica. Fasc. III. Brachelytra caucasi cum distributione geographica adnexis pselaphinis, scydmaenis, notoxidibus et xylophagis*, 44 pp., 3 pls.; Petropolis (Imperialis Academiae Scientiarum). <https://doi.org/10.5962/bhl.title.51370>
- KRAATZ, G. (1857): *Naturgeschichte der Insecten Deutschlands. Abt. 1. Coleoptera. Zweiter Band. Lieferung 3–4*, pp. 377–768; Berlin (Nicholaische Buchhandlung).
- LANFEAR, R., FRANDSEN, P. B., WRIGHT, A. M., SENFELD, T. & CALCOTT, B. (2017): Partitionfinder 2: new methods for selecting partitioned models of evolution for molecular and morphological phylogenetic analyses. – *Molecular Biology and Evolution* **34**: 772–773. <https://doi.org/10.1093/molbev/msw260>
- LEIGH, J. W. & BRYANT, D. (2015): POPART: Full-feature software for haplotype network construction. – *Methods in Ecology and Evolution* **6**: 1110–1116. <https://doi.org/10.1111/2041-210X.12410>

- LI, J. & CHEN, P. (1993): The rove beetles of Northeast China. – In: LI, J. & CHEN, P. (eds.): Studies of fauna and ecogeography of soil animal, 265 pp.; Changchun (Northeast Normal University Press). [In Chinese, with occasional English descriptions.]
- LUKHTANOV, V. A. (2024): Polytypic species concept and subspecies in the genomic era. – *Proceedings of the National Academy of Science* **121**: e2317038121. <https://doi.org/10.1073/pnas.2317038121>
- MATĚJČEK, J., CILLO, D. & BAZZATO, E. (2018): Prima segnalazione per la Sardegna di *Philonthus splendens* (Fabricius, 1792) (Coleoptera, Staphylinidae, Philonthina). – *Mediterraneanonline/Naturalistica* **1**: 76–79.
- MILNE, R. I. & ABBOTT, R. J. (2002): The origin and evolution of tertiary relict floras. – *Advances in Botanical Research* **38**: 281–314. [https://doi.org/10.1016/S0065-2296\(02\)38033-9](https://doi.org/10.1016/S0065-2296(02)38033-9)
- MUÑOZ-TOBAR, S. I. & CATERINO, M. S. (2020): Mountains as islands : species delimitation and evolutionary history of the ant-loving beetle genus *Panabachia* (Coleoptera, Staphylinidae) from the Northern Andes. – *Insects* **11**: 11–13. <https://doi.org/10.3390/insects11010064>
- NIKITSKY, N. B., OSIPOV, I. N., CHEREMIS, M. V., SEMENOV, V. B. & GUSAKOV, A. A. (1996): Xylobiont, mycetobiont and scarab beetles from Prioksko-Terrasny Biosphere Reserve (with review of the fauna of these groups in Moscow Region). – *Proceedings of the Zoological Museum of Moscow State University* **36**: 1–197.
- ÖZDEMİR, S. (2021): Faunistic contributions, and ecological and zoogeographical evaluations on Staphylininae (Coleoptera: Staphylinidae) fauna of Eastern Black Sea Region of Turkey. – *Transactions of the American Entomological Society* **147**: 929–959. <https://doi.org/10.3157/061.147.0408>
- PARK, J. Y., YOO, I. S. & AHN, K. J. (2024): Does coastal *Philonthus nudus* Sharp (Coleoptera: Staphylinidae: Staphylininae) comprise cryptic species? – *Journal of Asia-Pacific Entomology* **27**: 102176. <https://doi.org/10.1016/j.aspen.2023.102176>
- PSAREV, A. M., EREMEEV, E. A. & ZINCHENKO, V. K. (2020): Materials for the study of entomofauna of protected areas of Altai Krai: Ikonnikov Island. – *IOP Conference Series. Earth and Environmental Science* **548**: 1–5. <https://doi.org/10.1088/1755-1315/548/7/072073>
- PULLANDRE, N., BROUILLET, S. & ACHAZ, G. (2021): ASAP: assemble species by automatic partitioning. – *Molecular Ecology Resources* **21**: 609–620. <https://doi.org/10.1111/1755-0998.13281>
- PULLANDRE, N., LAMBERT, N., BROUILLET, S. & ACHAZ, G. (2012): ABGD, Automatic Barcode Gap Discovery for primary species delimitation. – *Molecular Ecology* **21**: 1864–1877. <https://doi.org/10.1111/j.1365-294X.2011.05239.x>
- RAMBAUT, A. (2018): FigTree v.1.4.4. Available from: <http://tree.bio.ed.ac.uk/software/figtree/> (accessed 12 August 2023).
- RAMBAUT, A., DRUMMOND, A. J., XIE, D., BAELE, G. & SUCHARD, M. A. (2018): Posterior summarization in Bayesian phylogenetics using Tracer 1.7. – *Systematic Biology* **67**: 901–904. <https://doi.org/10.1093/sysbio/syy032>
- RATNASINGHAM, S. & HEBERT, P. D. N. (2007): BOLD : The Barcode of Life Data System (www.barcodinglife.org). – *Molecular Ecology Notes* **7**: 355–364. <https://doi.org/10.1111/j.1471-8286.2007.01678.x>
- RONQUIST, F., TESLENKO, M., MARK, P. VAN DER, AYRES, D. L., DARLING, A., HÖHNA, S., LARGET, B., LIU, L., SUCHARD, M. A. & HUELSENBECK, J. P. (2012): MrBayes 3.2: Efficient bayesian phylogenetic inference and model choice across a large model space. – *Systematic Biology* **61**: 539–542. <https://doi.org/10.1093/sysbio/sys029>
- SALNITSKA, M., SOLODOVNIKOV, A. & ORLOV, I. (2022): Sampling and curation of rove beetles (Insecta, Coleoptera, Staphylinidae) for comprehensive and DNA-grade collections to enhance biodiversity exploration in Northern Eurasia. – *Biodiversity Data Journal* **10**: e96080. <https://doi.org/10.3897/BDJ.10.e96080>
- SCHEERPELTZ, O. (1933): Staphylinidae VII. – In: SCHENKLING, S. (ed.): *Coleopterorum Catalogus* 6 (129), pp. 989–1500; Berlin (W. Junk).
- SCHILLHAMMER, H. (2000): Revision of the East Palaearctic and Oriental species of *Philonthus* Stephens. Part 3. The *politus* complex. – *Koleopterologische Rundschau* **70**: 113–176.
- SCHILLHAMMER, H. (2003): Revision of the East Palaearctic and Oriental species of *Philonthus* Stephens. Part 5. The *rotundicollis* and *sanguinolentus* species groups. – *Koleopterologische Rundschau* **73**: 85–136.
- SCHILLHAMMER, H. (2009): Notes on some West Palearctic Staphylinini, with description of a new species from Spain (Coleoptera : Staphylinidae : Staphylininae). – *Koleopterologische Rundschau* **79**: 97–116.
- SCHILLHAMMER, H. (2012): Philonthina. – In: ASSING, V. & SCHÜLKE, M. (eds.): *Die Käfer Mitteleuropas. Band 4: Staphylinidae (exklusive Aleocharinae, Pselaphinae und Scydmaeninae)*. 2nd edition, pp. 397–450; Heidelberg (Spektrum Akademischer Verlag). <http://books.google.co.uk/books?id=xh1OAAAAYAAJ>
- SEMENOV, V. B., EGOROV, L. V. & VINOGRADOVA, E. Y. (2015): The staphylinid beetles annotated checklist of the Chuvash Republic, 144 pp.; Cheboksary (Novoe Vremya).
- SEMIONENKO, O. I., SEMENOV, V. B. & GILDENKOV, M. Y. (2015): Rove beetles (Coleoptera: Staphylinidae) of the West of the European part of Russia (excepting subfamilies Pselaphinae, Scydmaeninae and Saphidiinae), 392 pp.; Smolensk (Universum).
- SHEARER, T. L. & COFFROTH, M. A. (2008): Barcoding corals: limited by interspecific divergence, not intraspecific variation. – *Molecular Ecology Resources* **8**: 247–255. <https://doi.org/10.1111/j.1471-8286.2007.01996.x>
- SHORTHOUSE, D. P. (2010): SimpleMapp, an online tool to produce publication-quality point maps. Available from: <https://www.simplemapp.net/> (accessed: 12 August 2023).
- SMETANA, A. (1955): Beiträge zur Kenntnis der Gattung *Philonthus* Curt. II. (Coleoptera Staphylinidae). – *Annales Historico-Naturales Musei Nationalis Hungarici* **6**: 205–211.
- SMETANA, A. (1958): Fauna ČSR. Svazek 12. Drabčikovití–Staphylinidae. I. Staphylininae. (Řád: Brouci–Coleoptera), 435 pp.; Prague (Československá Akademie Věd).
- SMETANA, A. (1959): Bestimmungstabelle der mitteleuropäischen Arten der Gattung *Philonthus* Curt. sensu lato. – *Entomologische Blätter für Biologie und Systematik der Käfer* **54**: 140–175.
- SRIVATSAN, A., LEE, L., KATOH, K., HARTOP, E., KUTTY, S. N., WONG, J., YEO, D. & MEIER, R. (2021): ONTbarcoder and MinION barcodes aid biodiversity discovery and identification by everyone, for everyone. – *BMC Biology* **19**: 217. <https://doi.org/10.1186/s12915-021-01141-x>
- STAN, M. (2013): On the species of *Philonthus* Stephens (Coleoptera: Staphylinidae: Staphylininae: Staphylinini: Philonthina) in the collections of Romanian natural history

- museums. – *Travaux du Muséum National d'Histoire Naturelle 'Grigore Antipa'* **55**: 233–276.
<https://doi.org/10.2478/v10191-012-0016-8>
- TÓTH, L. (1984): Holyvák VII. - Staphylinidae VII. Magyarország állatvilága. Fauna Hungariae 159, 142 pp.; Budapest (Akadémiai Kiadó).
- TOUSSAINT, E. F. A., MORINIÈRE, J., MÜLLER, C. J., KUNTE, K., TURLIN, B., HAUSMANN, A. & BALKE, M. (2015): Comparative molecular species delimitation in the charismatic *Nawab* butterflies (Nymphalidae, Charaxinae, Polyura). – *Molecular Phylogenetics and Evolution* **91**: 194–209.
<https://doi.org/10.1016/j.ympev.2015.05.015>
- TRIFINOPOULOS, J., NGUYEN, L. T., HAESLER, A. VON & MINH, B. Q. (2016): W-IQ-TREE: a fast online phylogenetic tool for maximum likelihood analysis. – *Nucleic Acids Research* **44**: W232–W235.
<https://doi.org/10.1093/nar/gkw256>
- VESELOVA, E. M. & RYVKIN, A. B. (1991): On the fauna and ecology of Staphylinidae (Coleoptera) of Yenisey taiga. – In: *Biological resources and biocenoses Yenisey taiga*, pp. 178–199; Moscow (Institute of Animal Morphology and Ecology of USSR Academy of Sciences).
- VICTOROVICH, P. S. & PAVLOVICH, I. M. (2018): Endemism, relicts and invasion species [sic] of animals in structure of the biodiversity of the Ciscaucasia. – *Structure of the Biodiversity of the Ciscaucasia, Entomology and Applied Science Letters* **5**: 17–20.
- VITECEK, S., KUČINIĆ, M., PREVIŠIĆ, A., ŽIVIĆ, I., STOJANOVIĆ, K., KERESZTES, L., BÁLINT, M., HOPPELER, F., WARINGER, J., GRAF, W. & PAULS, S. U. (2017): Integrative taxonomy by molecular species delimitation: multi-locus data corroborate a new species of Balkan Drusinae micro-endemics. – *BMC Evolutionary Biology* **17**: 129.
<https://doi.org/10.1186/s12862-017-0972-5>
- VUKOJIĆIĆ, S., JAKOVLJEVIĆ, K., MATEVSKI, V., RANDJELOVIĆ, V., NIKETIĆ, M. & LAKUŠIĆ, D. (2014): Distribution, diversity and conservation of boreo-montane plant species in the central part of the Balkan Peninsula and the southern part of the Pannonian Plain. – *Folia Geobotanica* **49**: 487–505.
<https://doi.org/10.1007/s12224-014-9192-6>
- YOO, I. S., FRANK, J. H., JUNG, J. K. & AHN, K. J. (2022): Integrative taxonomy of coastal *Cafiusbistriatus* (Erichson) species complex (Coleoptera, Staphylinidae). – *Zookeys* **1100**: 57–70.
<https://doi.org/10.3897/zookeys.1100.79435>
- ZHANG, J., KAPLI, P., PAVLIDIS, P. & STAMATAKIS, A. (2013): A general species delimitation method with applications to phylogenetic placements. – *Bioinformatics* **29**: 2869–2876.
<https://doi.org/10.1093/bioinformatics/btt499>

Authors' addresses:

¹Natural History Museum of Denmark, University of Copenhagen, Universitetsparken 15, 2100, Copenhagen, Denmark; e-mails: lge@snm.ku.dk (LG; corresponding author), akhansen@snm.ku.dk (AKH), josh.shaw@snm.ku.dk (JJS), asolodovnikov@snm.ku.dk (AS); <https://orcid.org/0009-0000-5395-5044> (LG), <https://orcid.org/0000-0003-2089-7233> (AKH), <https://orcid.org/0000-0001-8585-2226> (JJS), <https://orcid.org/0000-0003-2031-849X> (AS)

²Center for Integrative Biodiversity Discovery, Leibniz Institute for Evolution and Biodiversity Science, Museum für Naturkunde, Invalidenstrasse 43, 10115 Berlin, Germany.

ZooBank registration: <https://zoobank.org/References/13A18867-A64E-4087-B6A7-3EE4C7F9D6F3>

Manuscript received: 16.I.2024; accepted: 22.IV.2024.

Supplementary Files:

[Available from: <https://doi.org/10.6084/m9.figshare.26073775>]

Supplementary File 1. The material examined. Available from: <https://doi.org/10.6084/m9.figshare.25000589.v1>

Supplementary File 2. *COI* data of *Philonthus* beetles from BOLD used for finding the sister group to *P. splendens* complex. Available from: <https://doi.org/10.6084/m9.figshare.23929185.v1>

Supplementary File 3. *COI* barcodes used in the species delimitation analysis of *Philonthus splendens*-complex. Available from: <https://doi.org/10.6084/m9.figshare.24466636.v1>

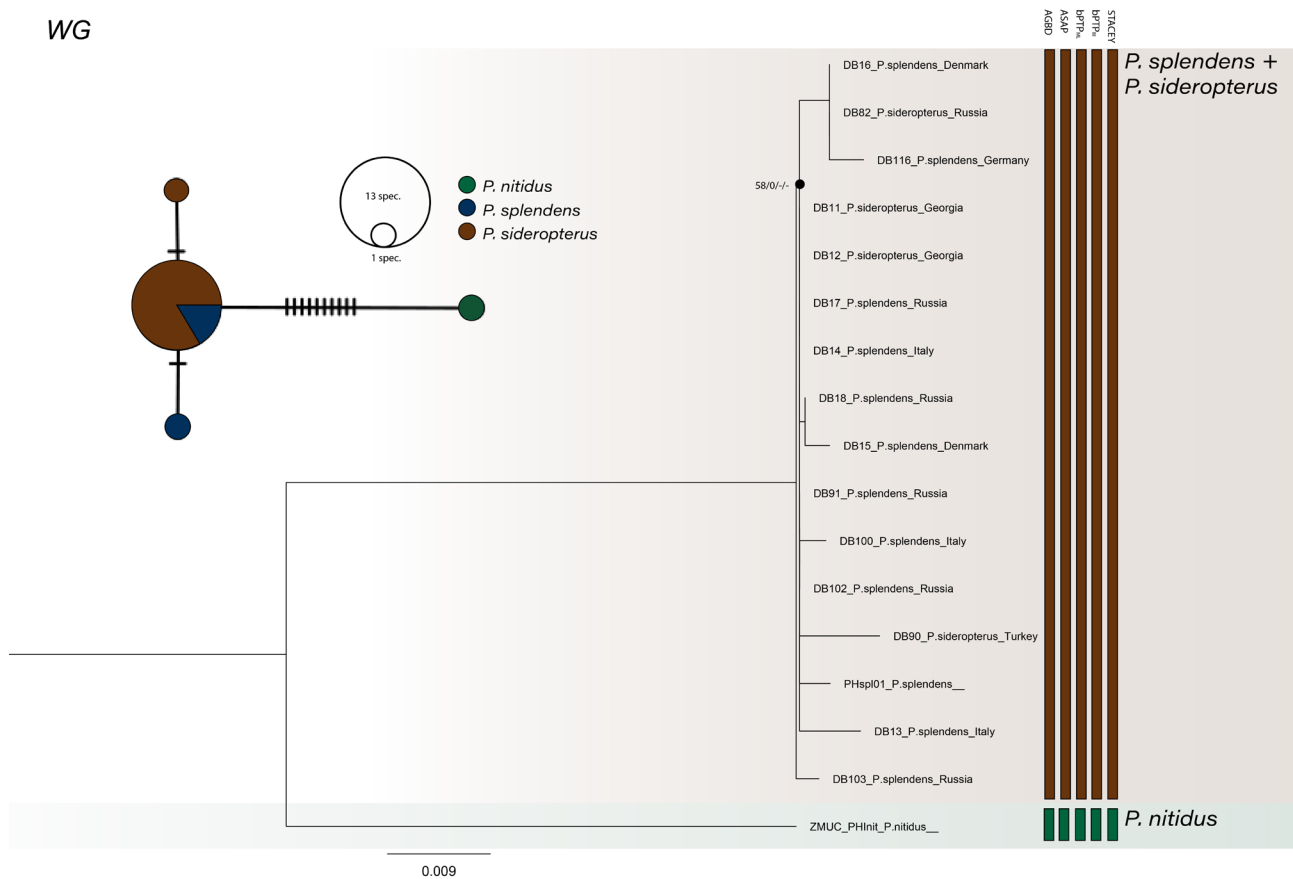

Supplementary Fig. 1. An integer neighbor-joining haplotype network (top left) and consensus phylogenetic tree based on Bayesian and Maximum Likelihood analyses of the *Wg* barcode, with support values. Support values at each node are shown in the following order: UFB, SH-aLRT, and PP. Bars with gaps on the right indicate the most probable clustering of three species delimitation methods. The size of the circles in the haplotype network is proportional to the number of specimens in the clusters; vertical bars between the clusters represent nucleotide differences. *Philonthus splendens* in brown, *P. sideroapterus* in blue, *P. nitidus* (outgroup) in green.

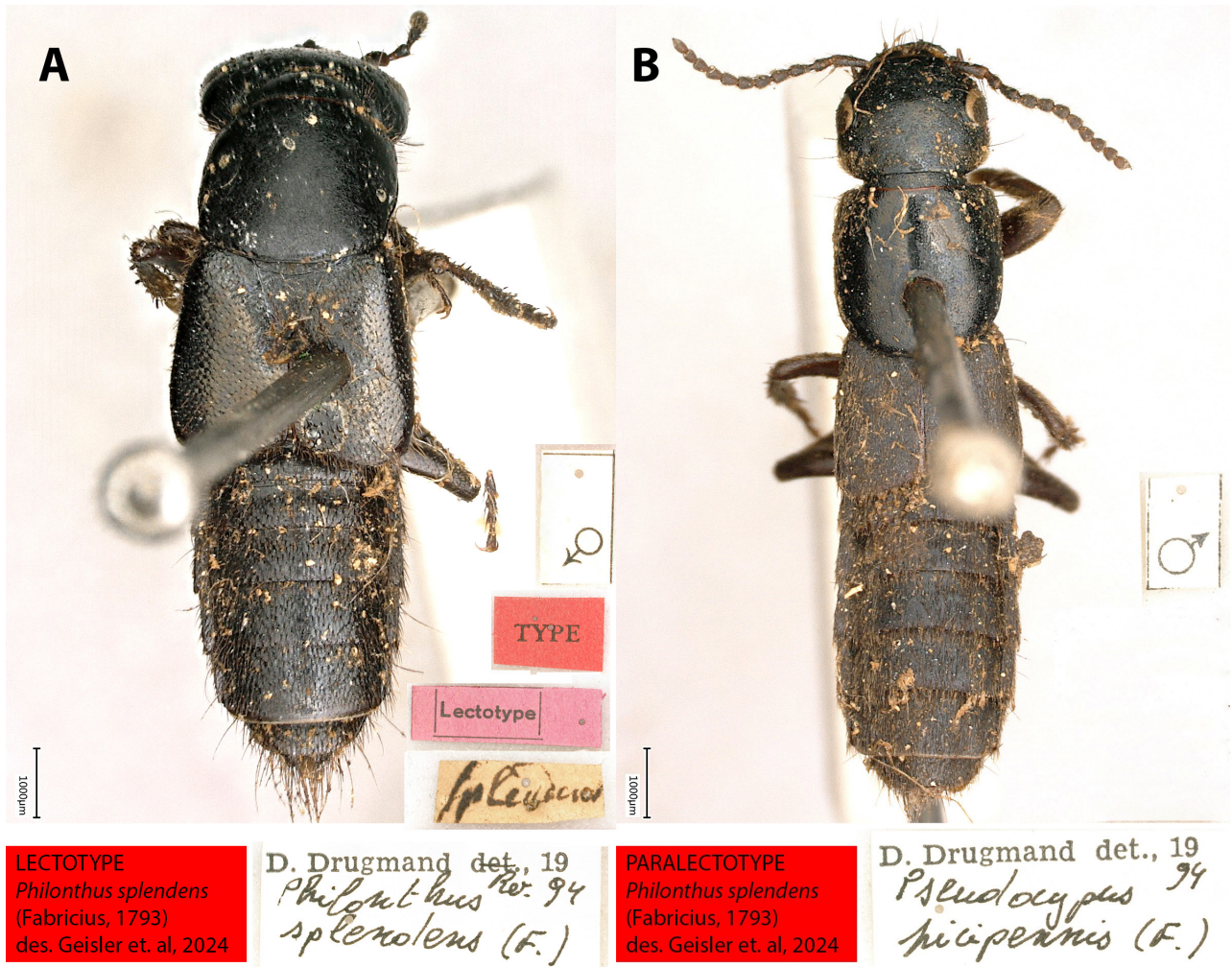

Supplementary Fig. 2. Lectotype and paralectotype of *Philonthus splendens* (Fabricius, 1793). **A.** Lectotype with original labels, labels of the unpublished lectotype designation by D. DRUGMAND, and our lectotype label. **B.** Paralectotype (identity: *Ocypus picipennis*) with the determination label by D. DRUGMAND and our paralectotype label.