



Evaluation of Water Intake in Seawater Adaptation in Eels Using a Synchronized Drop Counter and Pulse Injector System

Authors: Takei, Yoshio, Tsuchida, Takamasa, and Tanakadate, Akihiro

Source: Zoological Science, 15(5) : 677-682

Published By: Zoological Society of Japan

URL: <https://doi.org/10.2108/zsj.15.677>

BioOne Complete (complete.BioOne.org) is a full-text database of 200 subscribed and open-access titles in the biological, ecological, and environmental sciences published by nonprofit societies, associations, museums, institutions, and presses.

Your use of this PDF, the BioOne Complete website, and all posted and associated content indicates your acceptance of BioOne's Terms of Use, available at www.bioone.org/terms-of-use.

Usage of BioOne Complete content is strictly limited to personal, educational, and non - commercial use. Commercial inquiries or rights and permissions requests should be directed to the individual publisher as copyright holder.

BioOne sees sustainable scholarly publishing as an inherently collaborative enterprise connecting authors, nonprofit publishers, academic institutions, research libraries, and research funders in the common goal of maximizing access to critical research.

Evaluation of Water Intake in Seawater Adaptation in Eels Using a Synchronized Drop Counter and Pulse Injector System

Yoshio Takei^{1*}, Takamasa Tsuchida¹ and Akihiro Tanakadate²

¹*Ocean Research Institute, The University of Tokyo, Nakano, Tokyo 164-8639, Japan*

²*Department of Clinical Engineering, Allied Health Sciences, Kitasato University, Kitasato, Sagami-hara, Kanagawa 228-8555, Japan*

ABSTRACT—A new system has been developed for continuous measurement of drinking rate in eels in which drunk water exteriorized via an esophageal fistula was reintroduced into the stomach by a pulse injector synchronized with a drop counter. Using intact fish (controls), esophagus-cannulated fish whose drunk water was drained (drained fish), and esophagus and stomach-cannulated fish whose drunk water was reintroduced into the stomach (reintroduced fish), the validity of this system was examined by monitoring the changes in drinking rate and hydromineral balance after exposure to seawater (SW).

In reintroduced fish, the SW exposure was followed by an immediate burst of drinking and a subsequent cyclic pattern of drinking. The drained fish exhibited a similar pattern of drinking but at much higher rate. The plasma Na concentration and osmolality increased linearly for one day and then decreased gradually to a steady SW level in 5–6 days in control and reintroduced fish. However, both parameters increased linearly for 4–5 days in drained fish until they died at plasma osmolality of ca. 500 mOsm. The initial increase in plasma Na and osmolality was steeper for a day in control and reintroduced fish than in drained fish. Hematocrit scarcely changed for one week in control and reintroduced fish, but it increased abruptly from the second day in drained fish, suggesting severe hypovolemia.

These results show that the water and electrolyte balance of reintroduced fish were normal as in intact fish after exposure to SW. Thus, the drinking rate measured by the current system may represent actual drinking. The present study also provides first direct evidence to show that drinking plays a key role in SW adaptation in fish.

INTRODUCTION

The plasma of aquatic animals directly contacts environmental water only via a single layer of branchial respiratory cells, so that body water is lost or gained easily via the gill depending on the osmolality of environmental water (Maetz, 1971). For seawater (SW) fish, therefore, water drinking is the sole means to obtain water from the environment as in terrestrial animals (Maetz and Skadhauge, 1968). In fact, Hirano (1974) showed that in the eel drinking occurs immediately after exposure to SW in response to chloride ions in the media. The drunk SW is diluted to half in the esophagus by desalting (Hirano and Mayer-Gostan, 1976), and it is further diluted by the stomach and intestine to almost isotonic to plasma before being absorbed by the intestine (Loretz, 1995). The excess monovalent ions absorbed by the gut and gills are actively excreted by mitochondria-rich (chloride) cells of the gill and body surfaces (Zadunaisky, 1984), and the ex-

cess divalent ions are secreted by the renal proximal tubule into the urine (Beyenbach, 1995). Therefore, drinking appears to be the primary event that occurs in the process of SW adaptation in fish.

In order to analyze the mechanisms regulating drinking in fish, euryhaline species are frequently used because they possess mechanisms to start and stop drinking when environmental salinity changes (Evans, 1993). The drinking rate of fish has been measured by two methods. One is to dissolve a marker in environmental water and to measure its gut content after a certain period of time. Non-absorptive dyes such as phenol red (Oide and Utida, 1968; Kobayashi *et al.*, 1983) or radioactive tracers such as ⁵¹Cr-EDTA (Hazon *et al.*, 1989), ¹²⁵I-polyvinylpyrrolidone (Evans, 1968), or ³H-polyethylene glycol (Malvin *et al.*, 1980) are routinely used as markers. However, this method does not allow us to trace the time course of drinking in a single fish. Furthermore, it is not easy for this method to detect a burst of drinking that occurs within one minute after SW transfer (Hirano, 1974; Takei *et al.*, 1988b). To overcome these defects, the other method was established in which drinking is measured in a fish with an

* Corresponding author: Tel. +81-3-5351-6467;
FAX. +81-3-5351-6463.

esophageal fistula (Hirano, 1974; Takei *et al.*, 1979). This method enables to trace the change in drinking rate minute by minute, but since drunk water does not enter the intestine, the fish may suffer from gradual dehydration in SW because of the lack of water to compensate for the branchial loss. Furthermore, since stomach filling depresses drinking in the eel (Hirano, 1974), the lack of delivery of drunk water to the stomach may modify actual drinking.

In the present study, a new system has been established for continuous measurement of drinking rate in the eel. In this system, catheters were inserted into the esophagus and stomach of an eel, and the same volume of water drunk was injected into the stomach by a pulse injector synchronized with a drop counter. In order to examine whether the drinking measured in this system reflects the actual one, the changes in water and electrolyte balance were compared between intact eels and those subjected to the current system after exposure to SW.

MATERIALS AND METHODS

Animals

Cultured, immature eels, *Anguilla japonica*, were purchased from a local dealer. They were kept in a 1-ton freshwater (FW) tank for more than one week before use. Water in the tank was continuously filtered, aerated and regulated at $18 \pm 0.5^\circ\text{C}$. Eels were not fed after purchase. They weighed 197.3 ± 3.8 g (mean \pm SEM, $n = 17$) at the time of surgery.

Surgical procedures

After anesthesia of eels in 0.1% (w/v) tricaine methanesulfonate (Sigma, St. Louis, MO, USA) for 10 min, all fish were cannulated in

the ventral aorta with a polyethylene tube (o.d. : 0.8 mm, Natsume Seisakusho Co. Ltd., Tokyo, Japan). Twelve eels received another polyethylene catheter (o.d. : 1.6 mm, Becton Dickson Co., Sparks, MD, USA) in the esophagus and/or stomach as described previously (Takei *et al.*, 1979). The aortic catheter was used for blood collection, the esophageal catheter for measurement of drinking rate, and the stomach catheter for reintroduction of drunk water. The eels that bled more than 0.05 ml (ca. 0.7% of total blood volume) during surgery were excluded from the experiment. After surgery, eels were transferred to a plastic trough through which aerated and thermo-regulated (18°C) water constantly circulated (Fig. 1). In this condition, the cannulated eels survived more than 2 weeks. The catheter in the ventral aorta was connected to a syringe filled with isotonic (0.9%) NaCl solution. Eels were allowed to recover for more than 18 hr post-operatively.

Synchronized drop counter and pulse injector system

The catheter placed in the esophagus was connected to a drop counter for continuous measurement of drinking rate (Fig. 1). The volume of water that dropped from the esophageal catheter was 0.03 ml if the frequency was less than 2 drops/sec (216 ml/hr). The signal from the drop counter synchronously drove a pulse injector to reintroduce 0.03 ml of water into the stomach. After exposure to SW, the injectant was changed from FW to 80% SW because drunk SW was diluted to this concentration by the esophagus (Hirano *et al.*, 1976; Tsuchida and Takei, 1998). The total system was consisted of 6 sensors and 3 injectors in which 3 eels were measured at a time for drinking rate and urine flow rate (Fig. 2a). The data were stored in the memory of the drop counter and, whenever necessary, transmitted to a personal computer for analysis. A block diagram of the drop counter is shown in Fig. 2b. Direct printouts from the computer of drinking patterns analyzed by the hand-made program is shown in Fig. 3.

Experimental protocol

The eels were divided into 3 groups; intact fish (controls, $n = 5$), the fish whose drunk water was drained from the esophageal cath-

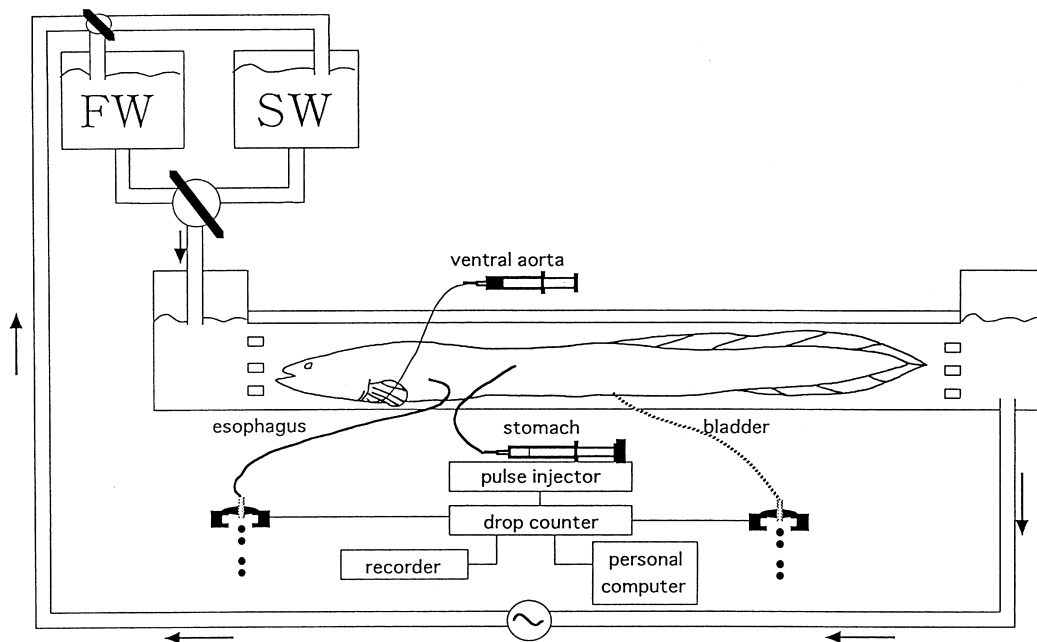

Fig. 1. An experimental setup for measurements of drinking rate and urine flow rate in the eel using a synchronized drop counter-pulse injector system. For detailed makeup of the system, see Fig. 2. The aortic catheter was used for blood sampling, esophageal catheter for measurement of water intake, and stomach catheter for reintroduction of drunk water. The bladder catheter was not inserted in the present study. The trough water can be changed from fresh water (FW) to seawater (SW) or *vice versa* only by turning a 3-way stopcock.

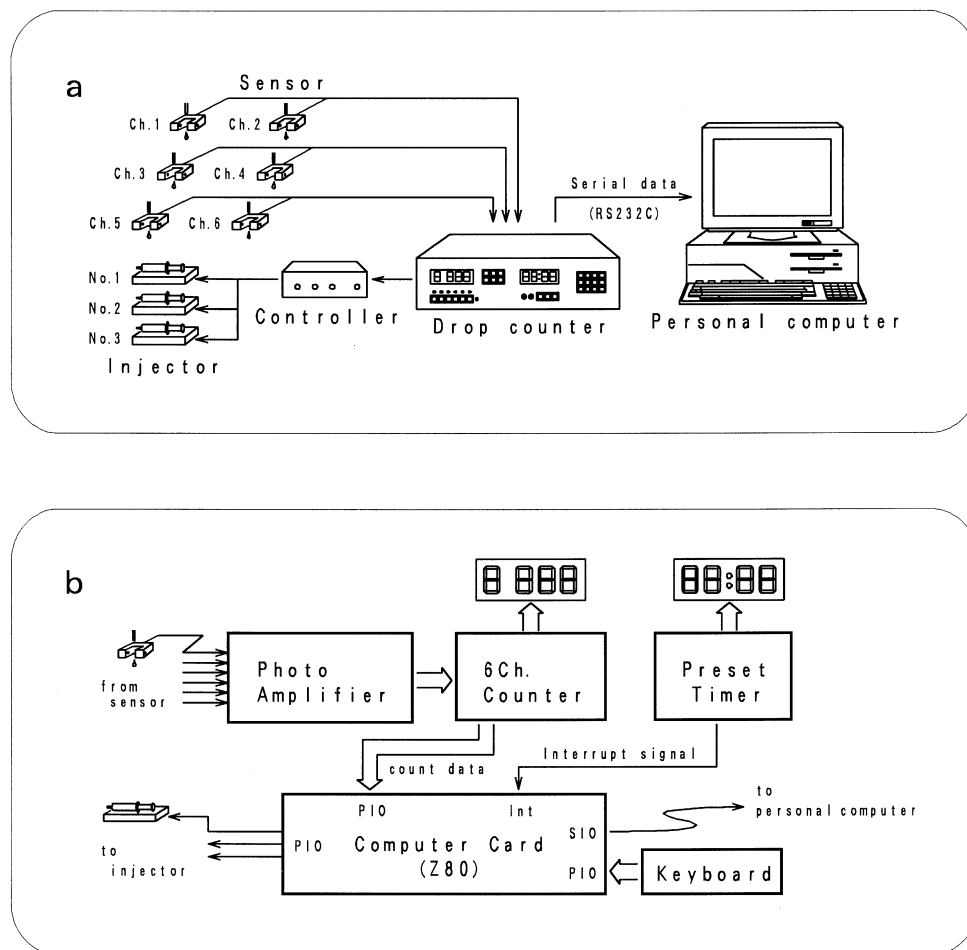

Fig. 2. (a) A hardware configuration of the system. Arrows indicate the direction of signal flow. The system consists of 6 sensors, 3 injectors, a drop counter, an injector controller, and a personal computer. Three fish can be measured at a time for drinking and urine flow rate. (b) A block diagram of the drop counter unit. A signal from the sensor is amplified and arranged in a square pulse by a photo amplifier. The number of pulses is counted and displayed on the panel. The number between 2 interrupt signals (1-99 min) from the preset timer is stored in the memory of the computer card. The capacity of the memory is 8 kilobytes for each channel. Each pulse is also sent to the pulse injector via an injector controller. The pulse injector is driven by a stepping motor, one step of which is adjusted to 0.03 ml by changing a gear ratio. The stored data are sent to the personal computer by operating the keyboard on the panel.

eter (drained fish, $n = 6$), and the fish whose drunk water was reintroduced into the stomach (reintroduced fish, $n = 6$). All of them were exposed to SW at time 0 by turning the 3-way stopcock (Fig. 1), and then 25-30 μl of blood was collected directly into a hematocrit tube at 1, 3, 6 and 12 hr and 1, 2, 3, 4, 5, 6 and 7 days after the exposure. The blood in the catheter was flushed with 50 μl of 0.9% NaCl solution. After measurement of hematocrit, Na concentration in plasma was determined in an atomic absorption spectrophotometer (Hitachi Z-5300, Tokyo, Japan) after dilution to 1/2,000. Plasma osmolality was measured in a vapor pressure osmometer (Wescor 5500, Logan, UT, USA). All determinations were made in duplicate or triplicate. Water intake was measured every 10 min with a drop counter as described above.

Analyses of data

Analysis of variance was used for statistical comparisons of plasma parameters between controls and drained or reintroduced fish. Significance was determined at $p < 0.05$. All results are expressed as means \pm SEM.

RESULTS

Changes in water intake

Drinking occurred immediately after exposure to SW in both drained fish and reintroduced fish which lasted for a few minutes as shown in individual fish (Fig. 3). After the initial burst of drinking, drained fish drank in various patterns, while a cyclic pattern of drinking was observed in most reintroduced fish. It is evident that the amount of water intake was much greater in the drained fish than in the reintroduced fish (Fig. 4) for both initial burst (ca. 27 ml/10 min vs. 12 ml/10 min) and subsequent drinking (ca. 8 ml/hr vs. 3 ml/hr).

Changes in water and electrolyte balance

Plasma Na concentration and osmolality increased immediately after exposure to SW in all groups of eels, but the increase was steeper in controls and reintroduced fish than in

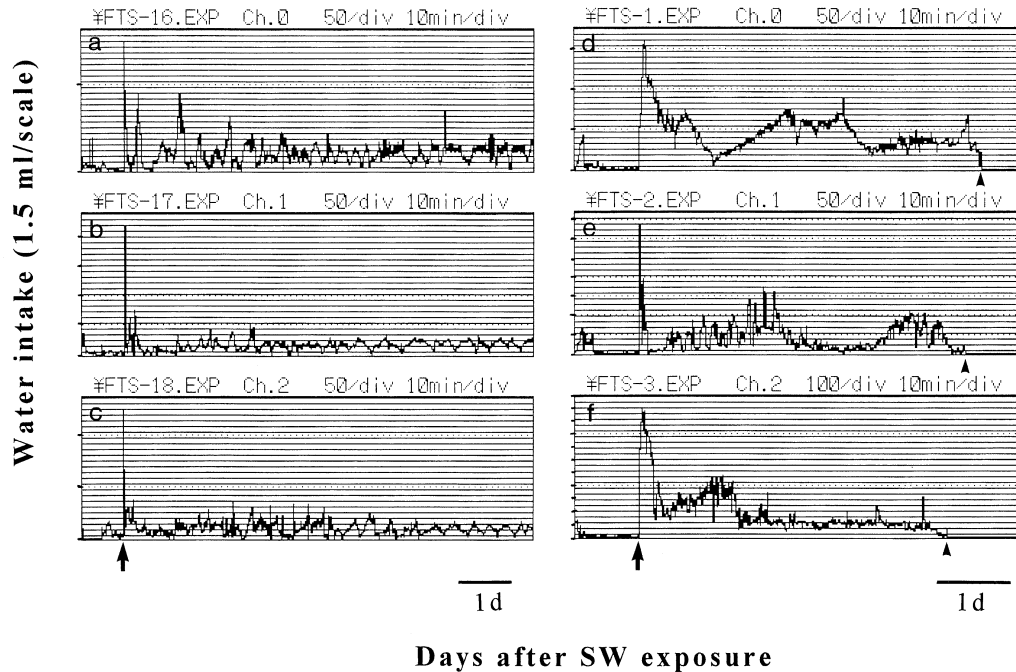

Fig. 3. Direct printouts from the personal computer of the pattern of drinking in reintroduced fish (a-c) and drained fish (d-f). Three fish are measured at a time. The height of each spike is the intake for 10 min. The interval of scales on the abscissa shows 1.5 ml of intake. Arrows and arrowheads show, respectively, the point of SW exposure and the point of death of eel.

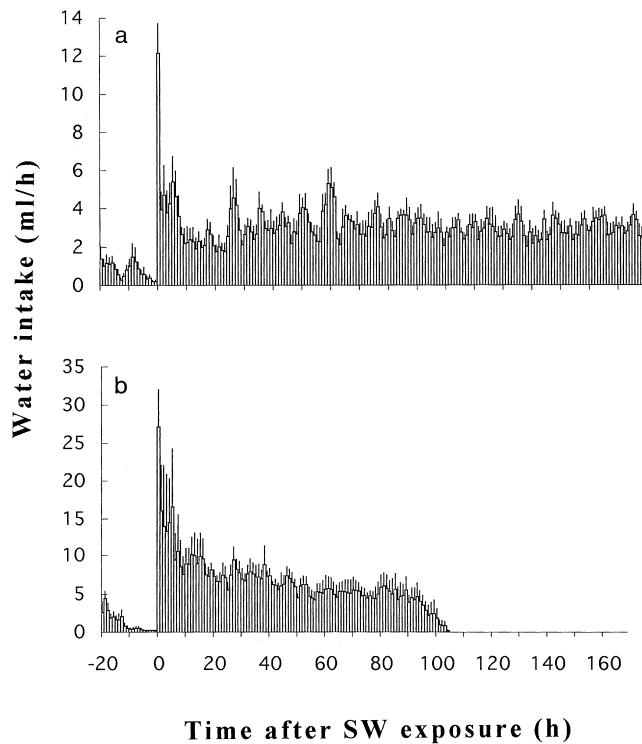

Fig. 4. Changes in drinking rate after exposure to seawater in (a) reintroduced fish and (b) drained fish ($n = 6$ in each case). The vertical bars represent SE of the mean. Most drained fish died ca. 100 hr after the exposure.

drained fish (Fig. 5a, b). The only difference between controls and reintroduced fish was that the maximum increase was smaller and the equilibrium was attained quicker in controls than in reintroduced fish. In drained fish, however, the increase in plasma Na concentration and osmolality was linear up to 4 days and the fish died when the increase reached 80% (ca. 270 mM for Na and 500 mOsm for osmolality).

The hematocrit was almost unchanged in controls and reintroduced fish for 7 days (Fig. 5c). In drained fish, however, it gradually increased for 2 days and the increase became abrupt thereafter to death.

DISCUSSION

The present study showed that the time course of changes in water and electrolyte balance after exposure to SW was similar between intact eels and reintroduced eels whose drunk water was re-injected into the stomach by the drop counter-pulse injector system. Therefore, the drinking observed in reintroduced eels most likely represents the actual one that occurs *in vivo* in intact eels. Radiolabelled substances which do not penetrate the gut epithelium are commonly used as tracers for measurement of drinking rate in aquatic animals (Evans, 1968; Carrick and Balment, 1983; Hazon *et al.*, 1989). This method allows to measure drinking rate with least disturbance to the animal, but it is impossible to trace the time course of drinking in a fish. Hirano (1974) has developed a new method using an esophageal fistula which removes disadvantages of

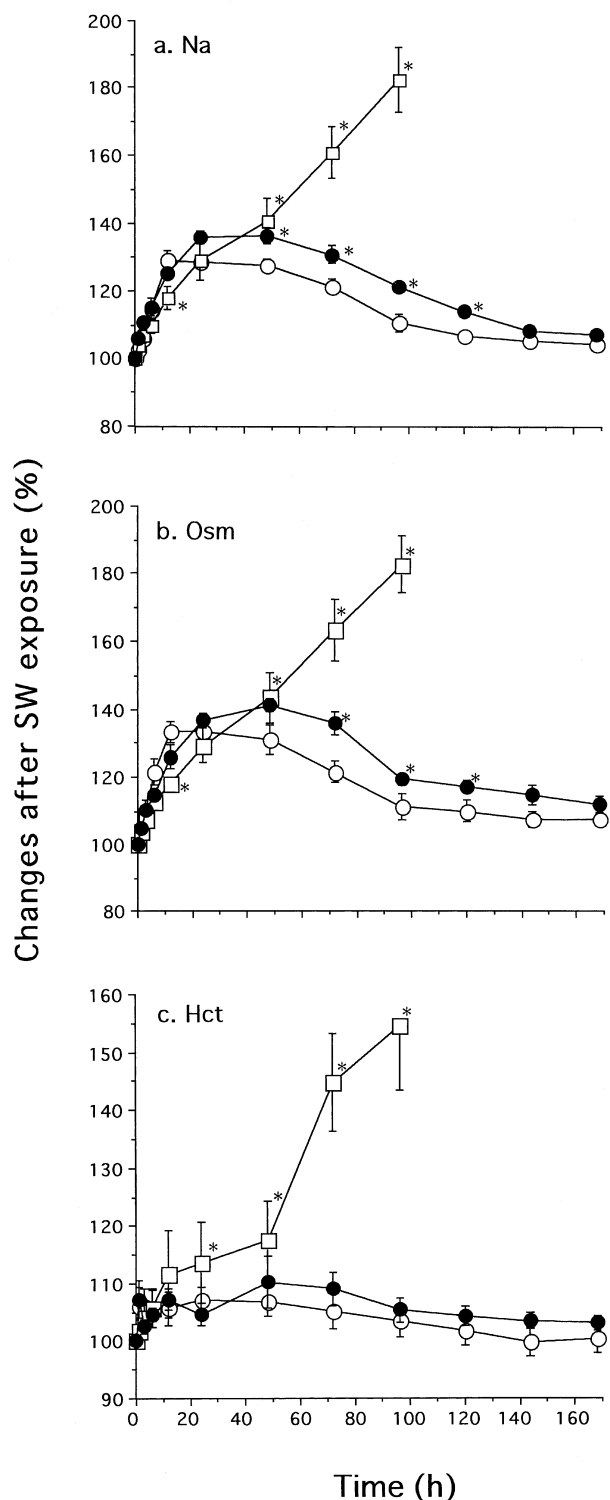

Fig. 5. Changes in (a) plasma Na concentration, (b) plasma osmolality, and (c) hematocrit after exposure to seawater in intact fish (○, n = 5), reintroduced fish (●, n = 6) and drained fish (□, n = 6). The initial Na concentration, osmolality and hematocrit are, respectively, 140.5 ± 2.3 mM, 269.5 ± 4.5 mOsm, and $25.4 \pm 0.6\%$ in intact fish (n = 5), 144.9 ± 2.1 mM, 264.6 ± 4.2 mOsm, and $25.1 \pm 0.9\%$ in reintroduced fish (n = 6), and 145.6 ± 2.2 mM, 271.2 ± 5.9 mOsm, and $24.7 \pm 0.8\%$ in drained fish (n = 6). *p < 0.05 compared with intact fish. The vertical bars show SE of the mean.

the tracer method. However, the fish with the fistula gradually falls into dehydration if it is in SW. The present method removes the disadvantage of this method.

It is generally believed that drinking of environmental SW is essential for the survival of teleost fish in SW because it is the sole means to take water in the body to compensate for the volume lost osmotically through the body surface (Evans, 1993). To our knowledge, however, there has been no report on how fish suffer from dehydration if their drinking is interrupted in SW. Therefore, the current study provides first direct evidence showing a critical role of drinking in SW adaptation in fish.

The reintroduced fish displayed a cyclic pattern of drinking which most probably reflects the actual pattern occurring *in vivo* in intact fish. The cyclic pattern may originate from the cycle of stomach distention and emptying because stomach distention strongly inhibits drinking in eels (Hirano, 1974). Since the sphincter is present between the stomach and intestine of eels, ingested water may be stored for some time in the stomach for dilution (Skadhauge, 1969; Hirano *et al.*, 1976), and sent from time to time into the intestine by relaxation of the sphincter. This filling and emptying of the stomach may result in a cyclic pattern of drinking. The lack of clear cyclic pattern in drained fish supports this notion. Furthermore, the greater initial burst of drinking in drained fish may be accounted for by the lack of stomach filling with drunk water. These results show that the gut is an important organ for regulation of drinking by monitoring the volume and ion concentrations of its content (Ando and Nagashima, 1996).

If drunk water was not reintroduced into the stomach, plasma Na concentration and osmolality increased linearly, and the fish died when the value reached a certain level. Since both plasma osmolality and hematocrit of the drained fish were higher than those of intact fish more than 2 days after exposure, they suffered from severe hypovolemia and hypernatremia. However, initial increases in plasma Na concentration and osmolality were slower in drained fish than in intact and reintroduced fish. This may be due to the absorption of Na from drunk SW by the gut in the latter two groups. Thus the hydromineral balance of drained fish differs from that of intact fish soon after exposure to SW. In fact, even the immediate burst of drinking after SW exposure was modified in drained fish as shown in this study.

The hydromineral balance was comparable between intact and reintroduced fish except slightly higher plasma osmolality for 2-5 days after SW exposure in reintroduced fish. We reintroduced 80% SW into the stomach when fish were in SW because our previous study showed that drunk SW was diluted to 80% when it dropped from the esophageal catheter (Tsuchida and Takei, 1998). However, SW may be diluted more in intact fish before entering the stomach because it stayed longer in the esophagus than in esophagus-cannulated fish. In the latter, drunk SW enters the catheter immediately because of the negative inner pressure of the catheter. Therefore, more diluted SW may have to be reintroduced into the stomach to mimic more precisely the

hydromineral balance of intact fish during the course of SW adaptation.

The present study showed that plasma Na concentration and osmolality increased immediately after SW exposure while hematocrit, an indicator of blood volume, scarcely changed for some time in all groups of eels. These results indicate that blood volume is more strictly maintained than plasma osmolality in the eel during the initial phase of SW adaptation. This is in contrast to the observation in mammals and birds where plasma Na concentration and osmolality are maintained constant at the sacrifice of blood volume during the initial phase of water deprivation (Fitzsimons, 1979; Takei *et al.*, 1988a). The primary regulation of plasma Na concentration in terrestrial animals is explained by the fact that it directly affects the neuronal activity. Since fish cells in culture are generally resistant to high environmental osmotic pressure and grow well in media of as high as 500 mOsm (Tocher *et al.*, 1994), the regulation of plasma osmolality may not be a priority in fish. This notion is supported by the fact that the eel can survive elevated plasma Na concentration and osmolality by 80% in the present study.

In summary, a new system has been developed for continuous measurement of drinking rate in eels whose drunk water was reintroduced into the stomach by a pulse injector driven synchronously by a drop counter. Changes in hydromineral balance after exposure to SW in these fish were similar to those of intact fish, showing that drinking also reflects that of intact fish. However, the eels whose drunk water was drained suffered from severe hypovolemia and hypernatremia and displayed much higher drinking rate than did reintroduced fish until they died. This result clearly shows that drinking is essential for SW adaptation in fish.

ACKNOWLEDGMENTS

We thank Mr. H. Ishikawa and Mr. M. Sohma of Kitasato University for their help in making the drop counter-pulse injector system. This investigation was supported by a grant from the Ministry of Education, Science, Sports and Culture of Japan (08640843 and 09102008).

REFERENCES

- Ando M, Nagashima K (1996) Intestinal Na⁺ and Cl⁻ levels control drinking behavior in the seawater-adapted eel *Anguilla japonica*. *J Exp Biol* 199: 711–716
- Beyenbach KW (1995) Secretory electrolyte transport in renal proximal tubules of fish. In "Cellular and Molecular Approaches to Fish Ionic Regulation" Ed by CM Wood, TJ Shuttleworth, Academic Press, San Diego, pp 85–105
- Carrick S, Balment RJ (1983) The renin-angiotensin system and drinking in the euryhaline flounder, *Plachthyes flesus*. *Gen Comp Endocrinol* 51: 423–443
- Evans DH (1968) Measurements of drinking rates in fish. *Comp Biochem Physiol* 25: 751–753
- Evans DH (1993) Osmotic and ionic regulation. In "The Physiology of Fishes" Ed by DH Evans, CRC Press, Boca Raton, pp 315–342
- Fitzsimons JT (1979) The Physiology of Thirst and Sodium Appetite. Cambridge Univ Press, Cambridge, pp 44–53
- Hazon N, Balment RJ, Perrott M, O'Toole LB (1989) The renin-angiotensin system and vascular and dipsogenic regulation in elasmobranchs. *Gen Comp Endocrinol* 74: 230–236
- Hirano T (1974) Some factors regulating water intake by the eel, *Anguilla japonica*. *J Exp Biol* 61: 737–747
- Hirano T, Mayer-Gostan N (1976) Eel esophagus as an osmoregulatory organ. *Proc Natl Acad Sci USA* 73: 1348–1350
- Hirano T, Morisawa M, Ando M, Utida S (1976) Adaptive changes in ion and water transport mechanism in the eel intestine. In "Intestinal Ion Transport" Ed by JWL Robinson, MTP, Lancaster, pp 301–317
- Kobayashi H, Uemura H, Takei Y, Itazu N, Ozawa M, Ichinohe K (1983) Drinking induced by angiotensin II in fishes. *Gen Comp Endocrinol* 49: 295–306
- Loretz CA (1995) Electrophysiology of ion transport in teleost intestinal cells. In "Cellular and Molecular Approaches to Fish Ionic Regulation" Ed by CM Wood, TJ Shuttleworth, Academic Press, San Diego, pp 25–56
- Maetz J (1971) Fish gills: Mechanisms of salt transfer in fresh-water and sea-water. *Phil Trans Roy Soc B* 262: 209–249
- Maetz J, Skadhauge E (1968) Drinking rates and gill ionic turnover in relation to external salinities in the eel. *Nature* 217: 371–373
- Malvin RL, Schiff D, Eiger S (1980) Angiotensin and drinking rates in the euryhaline killifish. *Am J Physiol* 239: R31–R34
- Oide H, Utida S (1968) Changes in intestinal absorption and renal excretion of water during adaptation to sea-water in the Japanese eel. *Marine Biol* 1: 172–177
- Skadhauge E (1969) The mechanism of salt and water absorption in the intestine of the eel (*Anguilla anguilla*) adapted to waters of various salinities. *J Physiol (London)* 204: 135–158
- Takei Y, Kobayashi H, Hirano T (1979) Angiotensin and water intake in the Japanese eel, *Anguilla japonica*. *Gen Comp Endocrinol* 38: 466–475
- Takei Y, Okawara Y, Kobayashi H (1988a) Drinking induced by water deprivation in the quail, *Coturnix coturnix japonica*. *J Comp Physiol B* 158: 519–525
- Takei Y, Okubo J, Yamaguchi K (1988b) Effects of cellular dehydration on drinking and plasma angiotensin II level in the eel, *Anguilla japonica*. *Zool Sci* 5: 43–51
- Tocher DR, Castell JD, Dick JR, Sargent JR (1994) Effects of salinity on the growth and lipid composition of Atlantic salmon (*Salmo salar*) and turbot (*Scophthalmus maximum*) cells in culture. *Fish Physiol Biochem* 13: 451–461
- Tsuchida T, Takei Y (1998) Effects of homologous ANP infusion on drinking and plasma angiotensin II level in eels adapted to fresh water or seawater. *Am J Physiol*, in press
- Zadunaisky JA (1984) The chloride cell: The active transport of chloride and the paracellular pathway. In "Fish Physiology Vol 11B" Ed by WS Hoar, DJ Randall, Academic Press, New York, pp 275–343

(Received April 23, 1998 / Accepted June 16, 1998)