

Host Plant Preference of *Melanotus communis* (Coleoptera: Elateridae) among Weeds and Sugar Cane Varieties Found in Florida Sugar Cane Fields

Authors: Michael Karounos, Ron Cherry, Dennis Otero, Hardev Sandhu, and Julien Beuzelin

Source: Florida Entomologist, 102(2) : 403-407

Published By: Florida Entomological Society

URL: <https://doi.org/10.1653/024.102.0213>

BioOne Complete (complete.BioOne.org) is a full-text database of 200 subscribed and open-access titles in the biological, ecological, and environmental sciences published by nonprofit societies, associations, museums, institutions, and presses.

Your use of this PDF, the BioOne Complete website, and all posted and associated content indicates your acceptance of BioOne's Terms of Use, available at www.bioone.org/terms-of-use.

Usage of BioOne Complete content is strictly limited to personal, educational, and non-commercial use. Commercial inquiries or rights and permissions requests should be directed to the individual publisher as copyright holder.

BioOne sees sustainable scholarly publishing as an inherently collaborative enterprise connecting authors, nonprofit publishers, academic institutions, research libraries, and research funders in the common goal of maximizing access to critical research.

Host plant preference of *Melanotus communis* (Coleoptera: Elateridae) among weeds and sugar cane varieties found in Florida sugar cane fields

Michael Karounos^{1,*}, Ron Cherry¹, Dennis Otero¹, Hardev Sandhu¹, and Julien Beuzelin¹

Abstract

The corn wireworm, *Melanotus communis* (Gyllenhal) (Coleoptera: Elateridae), is an important soil insect pest of Florida sugar cane (*Saccharum* spp.; Poaceae). The objective of this study was to determine the host plant preference of *M. communis* adults and larvae to weeds and sugar cane varieties found in Florida sugar cane fields. Three sugar cane varieties, 3 grass weeds, and 3 broadleaf weeds were tested for their attraction to the insects in free choice tests. After a 24 h exposure to whole plant extracts (juices), most adults were found in sugar cane varieties, followed by grass weeds, then broadleaf weeds. After a 48 h exposure to chopped roots in muck soil, most larvae were found in sugar cane varieties, followed by grass weeds, then broadleaf weeds. After a 48 h exposure to chopped roots in sandy soil, most larvae were found in sugar cane varieties, followed by broadleaf weeds, then grass weeds. Our data show that in free choice tests, both *M. communis* adults and larvae prefer sugar cane over weeds present in Florida sugar cane fields.

Key Words: wireworms; click beetles; ecology; *Saccharum*

Resumen

El gusano del maíz, *Melanotus communis* (Gyllenhal) (Coleoptera: Elateridae), es una plaga importante de la caña de azúcar (*Saccharum* spp.; Poaceae) en la Florida. El objetivo de este estudio fue determinar la preferencia de la planta hospedera de los adultos y larvas de *M. communis* a las malezas y variedades de caña de azúcar que se encuentran en los campos de caña de azúcar de la Florida. Se probaron tres variedades de caña de azúcar, 3 pastos-malezas y 3 malezas de hoja ancha por su atracción hacia los insectos en pruebas de libre elección. Después de una exposición de 24 h a extractos de plantas enteras (jugos), la mayoría de los adultos se encontraron en variedades de caña de azúcar, seguidos de los pastos-malezas y luego malezas de hoja ancha. Después de una exposición de 48 h a las raíces cortadas en el suelo de lodo, la mayoría de las larvas se encontraron en variedades de caña de azúcar, seguidas de los pastos-malezas y luego las malezas de hoja ancha. Después de una exposición de 48 h a las raíces picadas en el suelo arenoso, la mayoría de las larvas se encontraron en variedades de caña de azúcar, seguidas por los pastos-malezas y luego por las malezas con hojas anchas. Nuestros datos muestran que en las pruebas de libre elección, tanto los adultos como las larvas de *M. communis* prefieren la caña de azúcar en lugar de las malezas presentes en los campos de caña de azúcar en la Florida.

Palabras Clave: gusanos de alambre; elateridos; ecología; *Saccharum*

Sugar cane (*Saccharum* spp.; Poaceae) is Florida's major field crop, being grown in southern Florida on 159,902 ha in 2017 (VanWeelden et al. 2018). Click beetles (Coleoptera: Elateridae), known as wireworms in their larval stage, are insect pests of newly planted sugar cane in Florida. The dominant elaterid species attacking Florida sugar cane is *Melanotus communis* (Gyllenhal) (Coleoptera: Elateridae), as shown in field surveys (Cherry & Stansly 2008; Cherry et al. 2017). They have been the wireworms of utmost importance to growers since the earliest years of Florida sugar cane (Gifford 1964). It also is the most common wireworm in corn fields (*Zea mays* L.; Poaceae) in the north-central states of the USA, and is commonly called the corn wireworm (Riley et al. 1974). It is also a serious pest of potatoes (*Solanum tuberosum*; Solanaceae), feeding on the seed pieces, and causing weak stands and tunneling into tubers (Jansson & Lecrone 1989).

Our current knowledge of elaterid feeding ecology remains rudimentary (Traugott et al. 2015), and this is true especially for *M. communis* in Florida sugar cane. Weeds are ubiquitous throughout Florida

sugar cane (Otero et al. 2013). Understanding weed-insect interactions is complex, especially with systems such as sugar cane, which contain a variety of weeds external to and within the crop system. Weeds can be food sources and oviposition sites for soil insects (Norris & Kogan 2000). Our objective was to determine host plant preference of *M. communis* adults and larvae to some common weeds and sugar cane varieties found in Florida sugar cane fields.

Materials and Methods

INSECT COLLECTION

Adults were collected using ultraviolet light traps adjacent Florida sugar cane fields. Traps ran nightly from the last wk of May through the second wk of Jul 2017. This is the period of maximum flight activity of *M. communis* in southern Florida (Cherry & Hall 1986). Adults were

¹University of Florida, Institute of Food and Agricultural Sciences, Everglades Research and Education Center, Belle Glade, Florida 33430, USA; E-mail: karounos@gmail.com (M. K.); rcherry@ufl.edu (R. C.); dcobero@ufl.edu (D. O.); hsandhu@ufl.edu (H. S.); jbeuzelin@ufl.edu (J. B.)

*Corresponding author; E-mail: karounos@gmail.com

stored at 24 °C in moist Dania muck with sliced carrots for food. Muck is the highly organic (> 70% soil organic matter) where *M. communis* is most abundant in Florida sugar cane (Cherry & Stansly 2008), and the mean annual soil temperature in the fields is 24 °C (Cherry 1991). Muck for adult storage was collected from sugar cane fields and heat sterilized to reduce broad mite (*Polyphagotarsonemus latus* [Banks]; Prostigmata: Tarsonemidae) infestations. Larvae were collected by digging under Florida sugar cane stools where they are aggregated (Cherry 2007). After collection, to simulate natural conditions, larvae also were stored in moist muck soil at 24 °C with sliced carrots provided for food. The moist muck used in storage and in all tests was approximately 50% water by weight as determined by oven-drying soil.

PLANT TREATMENTS

The use of plant parts and plant extracts in testing insect orientation and feeding responses is common. More specifically, Thorpe et al. (1947) tested feeding responses of *Agriotus* (Coleoptera: Elateridae) spp. wireworms to juices of several commercial plant crops. Also, Davis (1961) reported the biting response of larvae of the prairie grain wireworm, *Ctenicera aeripennis* (Brown) (Coleoptera: Elateridae), to extracts of rye (*Secale cereale*; Poaceae) seeds. Crude extracts from whole plants of butterfly milkweed (*Asclepias tuberosa*; Apocynaceae) were tested for feeding deterrence to *M. communis* wireworms by Viliani and Gould (1985).

In our tests, we used plant extracts (juices) for adult tests and plant parts (roots) for larval tests to determine host plant preference. Ten treatments were used in tests. Nine treatments with plants were 3 sugar cane varieties, 3 grass weed species, and 3 broadleaf weed species. The tenth treatment was a control, e.g., soil without plant material. The sugar cane varieties 'CP96-1252,' 'CP88-1762,' and 'CP00-1101' are the most, seventh-most, and eleventh-most grown in the Everglades Agricultural Area, respectively (VanWeelden et al. 2018). Sugar cane used in our tests was harvested at the Everglades Research and Education Center at Belle Glade, Florida, USA. The weed species selected for this study are major weed pests for Florida sugar cane growers (Odero et al. 2013; Rott et al. 2018). Weedy host species were dug up individually, and whole by shovel and hand within fields at the Research Center. The grass weeds used were columbus grass (*Sorghum almum* Parodi; Poaceae), fall panicum (*Panicum dichotomiflorum* Michx.; Poaceae), and elephant grass (*Pennisetum purpureum* Schumach.; Poaceae). The broadleaf weeds used were spiny amaranth (*Amaranthus spinosus* L.; Amaranthaceae), common ragweed (*Ambrosia artemisiifolia* L.; Asteraceae), and common purslane (*Portulaca oleracea* L.; Portulacaceae).

ADULT FREE CHOICE TEST

Adult *M. communis* are found both above- and below-ground, so both stalks and roots may serve as cues for adult host plant preference. Therefore, whole plants were collected for the adult study. Whole plants were rinsed thoroughly with water and shredded into pulp using a Dedini sugar cane shredder (Dedini Indústrias De Base, Piracicaba, São Paulo, Brazil). Approximately 1 kg of pulpy plant material was pressed for juice in a Dedini hydraulic press with a maximum pressure of 700 kPa. The juice extract was aliquoted into 30 mL graduated jars and frozen at -18 °C. They were removed from the freezer and thawed at 25 °C before each replicate.

Tests were conducted in a temperature-controlled insectary at 26 °C with a 14:10 h (L:D) photoperiod. Tests were conducted inside cubic aluminum screen mesh cages with 61 cm sides (Bioquip 1450D, Rancho Dominguez, California, USA). Fisherbrand 100 × 15 mm polystyrene Petri dishes (Thermo Fisher Scientific, Waltham, Massachusetts,

USA) were modified to contain the plant treatments. One replicate consisted of 1 cage with 10 dishes, each containing 1 plant treatment spaced uniformly in a circular pattern at the base of the cage (Fig. 1). Eight replicates were made and placement of treatments were randomized within each replicate. The top of the Petri dish lid was painted black because adults hide in sugar cane litter during daylight. This cryptic behavior also has been observed by Fenton (1926), who found large numbers of adult *M. communis* under tree bark in Iowa, USA. The dish base was modified by creating 2 cm entrance sections on 4 opposite sides to allow adults entry into the dish. Sixty mL of newly collected, filtered (with a 4.75-mm sieve), and homogenized muck soil was added into the Petri dish. Ten mL of plant extract was the maximum that could be absorbed into the muck soil in each dish without spilling out of the dish. Therefore, 10 mL of plant juice was used in each Petri dish for each plant treatment for each replicate.

Forty active adults were released into the center of the circle of 10 equally spaced dishes. Sex of the adults used was unknown, because the 2 sexes are externally very similar. The mesh cage was subsequently closed and left in the insectary for 24 h before being examined. The contents of each dish were emptied into labelled plastic bags and frozen immediately. Adults found outside the dishes were counted as no choice. Adults were dissected to determine sex using genitalia (Quate & Thompson 1967). Data analyses comparing means of total adults, male adults, and female adults among treatments, and also pooled by plant treatment type (sugar cane, grass weed, broadleaf weed) were performed with Fisher's LSD, $\alpha = 0.05$, using R (LSD.test; R Core Team 2014).

LARVAL FREE CHOICE TESTS

Unlike adults, which primarily occur during May to Jun in Florida sugar cane (Cherry & Hall 1986), wireworms are found throughout the yr (Cherry 2007). This extended period for wireworm availability allowed us to test wireworms in both muck and sand soil types in which they occur in Florida sugar cane (Cherry & Stansly 2008). Sand (Riviera sand), like the muck soil, was collected by digging from fields in Palm Beach County, Florida, which is the largest sugar cane-growing county in Florida. Tests with larvae were conducted in the same insectary light and temperature conditions as described in the adult tests. Wireworms have highly variable feeding behavior and feed infrequently (Traugott et al. 2015; Karounos et al. 2018). Hence, researchers have starved larvae to enhance their feeding behavior for feeding tests (Keaster et al. 1975; van Herk & Vernon 2007; Cherry & Nuessly 2010). In our tests, larvae were starved 2 wk prior to testing to induce searching behavior for host plants.

The 10 plant treatments used were the same as in adult tests. However, instead of whole plant juices, chopped roots (3 cm pieces) were used, because *M. communis* larvae are soil-dwelling and found in root systems of host plants. Plant roots were collected, rinsed in water, and frozen to ensure availability during the experiment. Before each test, roots were thawed, weighed, and chopped as needed.

Circular uncoated aluminum pans (Nordic Ware, St. Louis Park, Minnesota, USA), 35 cm diam and 4 cm deep, were used for larval tests. A modified version of bioassays utilizing a circular pan for observing larval orientation and feeding behavior was used (Apablaza et al. 1977; van Herk & Vernon 2007). The pan was filled to a depth of 2 cm with moist soil, and covered with a clear glass pane to prevent it from drying out.

The 10 treatment dishes were spaced out evenly in a radial pattern in the pan (Fig. 2). Each radial sector measured 11 cm of the circumference, and 10 cm of radius into the pan. The remaining center area where the insects were placed initially in the pan measured 15 cm in diam and was considered the no-choice zone. A maximum of 3

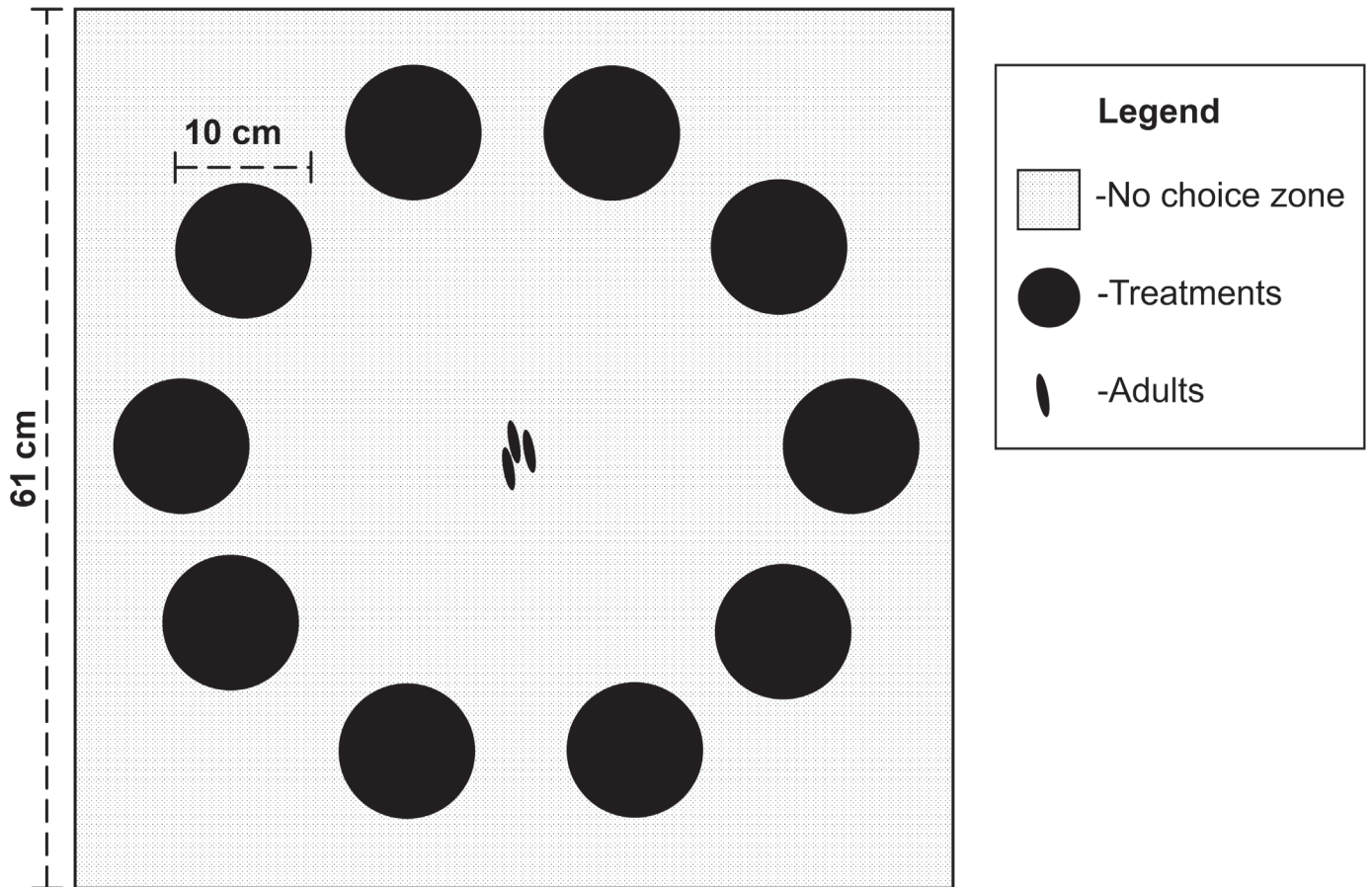

Fig. 1. Diagram of the adult host plant tests.

g of chopped root material could be used per treatment without interfering with the neighboring treatments so that root materials were not touching. Roots were thawed, washed, chopped, homogenized, weighed to 3 g, then buried in soil along the outer rim of the pan. The control treatment was moist soil only.

Each replicate consisted of 20 larvae placed into the center of the circular pan, and placement of treatments was randomized within each replicate. Larval weight was measured before and after each replicate. Larvae used in this test were an initial mean weight of 72 mg. Larvae were given more time than the adults (48 versus 24 h) to move freely in the pan arena, and orient because of their limited movement through soil compared to adults in open air. Eight replicates using muck soil and 8 replicates using sand were conducted.

The material from each sector was collected after 48 h. Roots were separated, and soil was carefully sifted for larvae. Larvae found in the 15 cm diam center of the pan, and therefore outside the treatment sectors, were considered to have displayed no choice. Mean numbers of larvae found in treatments, and pooled by plant type (sugar cane, grass weed, broadleaf weed), were analyzed with Fisher's LSD, $\alpha = 0.05$, using R (LSD.test, R Core Team 2014).

Results and Discussion

ADULT FREE CHOICE TEST

Adults were found in 85% of treatments with 15% non-responsive to treatments. Two treatments differed significantly from the water

control (Table 1). Sugar cane variety CP88-1762 had significantly more adults than the water control and all other treatments. Ragweed had significantly less adults than the water control. When treatments were pooled by plant type, the mean abundance of adults associated with sugar cane varieties was significantly greater than broadleaf weeds, but not significantly greater than grass weeds.

At the test conclusion, adults were dissected and 89% were male while 11% were female. This sex ratio is consistent with adult light trap catches of *M. communis* reported by Cherry and Hall (1986). Forty-two, 32, and 26% of male adults were found in sugar cane, grass weed, and broadleaf weed treatments, respectively. Sixty-two, 27, and 12% of female adults were found in sugar cane, grass weed, and broadleaf weed treatments, respectively. These data indicate that both sexes were responding similarly to the host plant treatments.

LARVAL TEST IN MUCK

Seventy-three percent of larvae were found in treatment sectors, and 27% in the center no-choice zone. Variability within treatments was high, which partially explains why no treatment was significantly different than the control (Table 2). However, it should be noted that the 2 greatest means of larvae per treatment both occurred in 2 of the 3 sugar cane varieties. Also, the third sugar cane variety (CP96-1252) was in the upper 50% of the treatments when considering mean number of larvae per treatment. The overall preference of sugar cane shows up more clearly when treatments are pooled by plant type. Here, significantly more wireworms were found in the 3 sugar cane varieties than in either the 3 grass weed species or 3 broadleaf weed species.

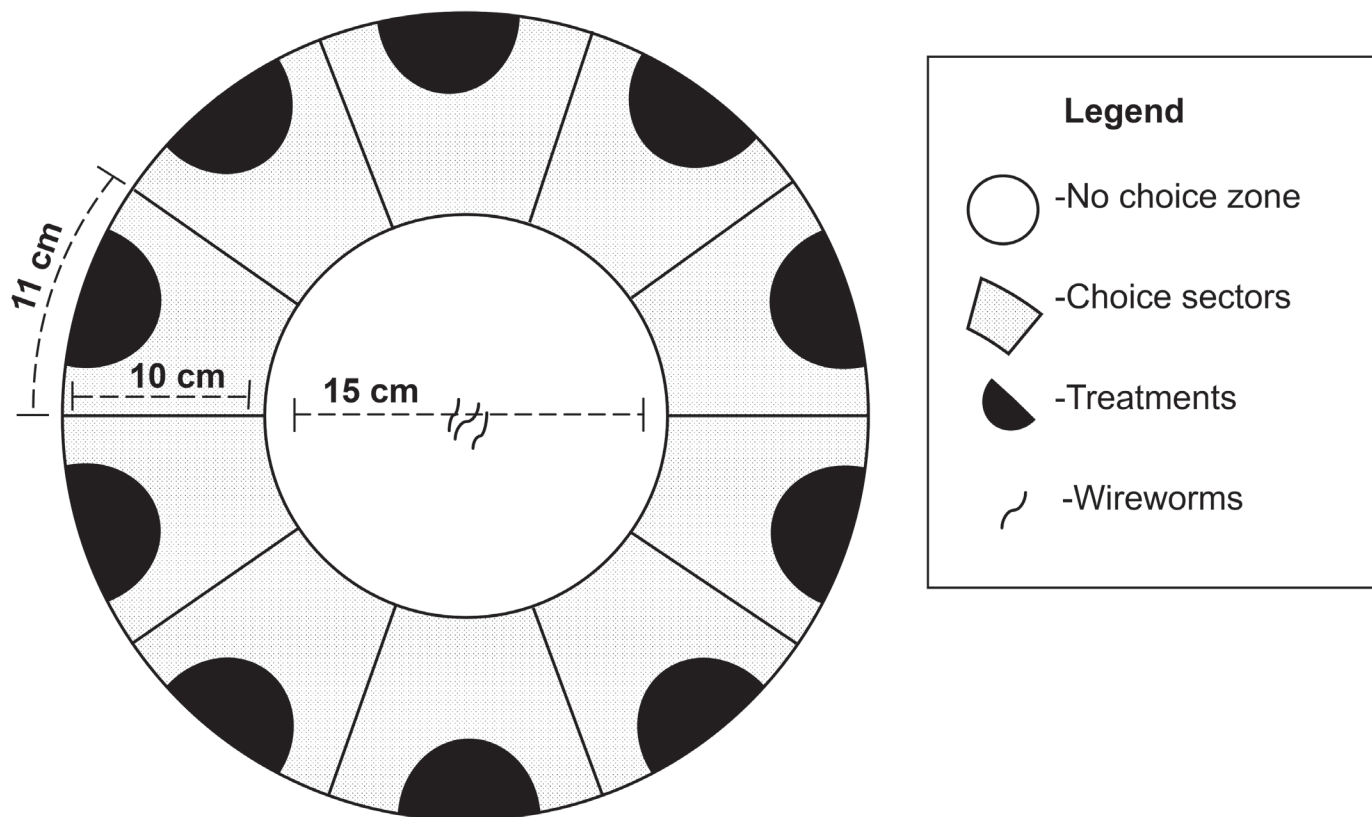

Fig. 2. Diagram of the larval host plant tests.

LARVAL TEST IN SAND

Observations in this test were comparable to those in the larval free choice test in the muck soil. Seventy-four percent of larvae were found in the treatment sectors, and 26% in the center no-choice zone. The greatest number of wireworms was associated with sugar cane variety CP00-1101; this number was significantly greater than in any of the other nine treatments (Table 3). Also, 3 of the 4 greatest means for larvae per treatment occurred in the 3 sugar cane varieties. The overall

preference for sugar cane again shows up more clearly when treatments are pooled by plant type. Here, significantly more wireworms were found in the 3 sugar cane varieties than in either the 3 grass weed species or the 3 broadleaf weed species.

In summary, as noted earlier, our current knowledge of feeding ecology remains rudimentary (Traugott et al. 2015), and this is especially true for *M. communis* in Florida sugar cane. Also, as noted by Thorpe et al. (1947), field observations on how wireworms find their food in soil are difficult to evaluate. This difficulty in field observations has resulted

Table 1. Adult *Melanotus communis* found in free choice tests after exposure to 10 mL whole plant juices for 24 h.

Plant type	Mean ^a	SD	Pooled mean ^a	SD
Broadleaf weeds				
Common purslane	3.8 b	2.9		
Spiny amaranth	2.3 bc	1.9	2.3 b	2.4
Ragweed	0.9 c	1.1		
Grass weeds				
Elephant grass	3.5 b	2.1		
Sorghum grass	2.4 bc	1.9	3.0 ab	1.8
Fall panicum	3.1 bc	1.4		
Sugar cane varieties				
CP88-1762	7.0 a	3.7		
CP96-1252	3.0 bc	2.5	4.3 a	3.3
CP00-1101	2.8 bc	1.8		
Control	3.5 b	2.1		

^aMeans in a column followed by the same letter are not significantly different ($\alpha = 0.05$) using LSD. Pooled mean is the overall mean of the plant type.

Table 2. Larval *Melanotus communis* found in free choice tests after exposure to 3 g of chopped roots in muck soil for 48 h.

Plant type	Mean ^a	SD	Pooled mean ^a	SD
Broadleaf weeds				
Common purslane	0.8 b	0.5		
Spiny amaranth	1.6 ab	1.8	1.2 b	1.3
Ragweed	1.1 ab	1.2		
Grass weeds				
Elephant grass	1.3 ab	1.8		
Sorghum grass	0.8 b	1.0	1.3 b	1.4
Fall panicum	1.8 ab	1.2		
Sugar cane varieties				
CP88-1762	2.5 a	1.2		
CP96-1252	1.6 ab	1.6	2.1 a	1.5
CP00-1101	2.1 ab	1.7		
Control	1.1 ab	0.8		

^aMeans in a column followed by the same letter are not significantly different ($\alpha = 0.05$) using LSD. Pooled mean is the overall mean of the plant type.

Table 3. Larval *Melanotus communis* found in free choice tests after exposure to 3 g of chopped roots in sand soil for 48 h.

Plant type	Mean ^a	SD	Pooled Mean ^a	SD
Broadleaf weeds				
Common purslane	1.0 bc	1.1		
Spiny amaranth	2.0 b	1.4	1.4 b	1.2
Ragweed	1.1 bc	1.1		
Grass weeds				
Elephant grass	1.3 bc	1.0		
Sorghum grass	0.9 bc	0.6	1.0 b	0.8
Fall panicum	0.9 bc	0.6		
Sugar cane varieties				
CP88-1762	1.8 bc	0.9		
CP96-1252	1.5 bc	0.9	2.3 a	1.6
CP00-1101	3.8 a	1.8		
Control	0.6 c	0.7		

^aMeans in a column followed by the same letter are not significantly different ($\alpha = 0.05$) using LSD. Pooled mean is the overall mean of the plant type.

in wireworm feeding studies generally being conducted in laboratories under controlled conditions, as was done in this study. Throughout this study, variability was frequently high within individual plant treatments. However, when viewed by plant types, the data are consistent. In free choice tests in muck soil, more adults were found associated with sugar cane residues than grass or broadleaf weeds. In free choice tests in both muck and sandy soil, more larvae were found associated with sugar cane than grass or broadleaf weeds. These data show that both adults and larvae of *M. communis* prefer sugar cane over weeds, which partially explains why the insects are pests in Florida sugar cane.

Acknowledgments

This research was supported by the Florida Sugar Cane League.

References Cited

- Apablaza J, Keaster A, Ward R. 1977. Orientation of corn-infesting species of wireworms toward baits in the laboratory. *Environmental Entomology* 6: 715–718.
- Cherry R. 1991. Feeding rates of different larval instars of a sugarcane grub, *Li-gyrus subtropicus* Blatchley. *Journal of Agricultural Entomology* 8: 163–168.
- Cherry R. 2007. Seasonal population dynamics of wireworms (Coleoptera: Elateridae) in Florida sugarcane fields. *Florida Entomologist* 90: 426–431.
- Cherry R, Hall D. 1986. Flight activity of *Melanotus communis* (Coleoptera: Elateridae) in Florida sugar cane fields. *Journal of Economic Entomology* 79: 626–628.
- Cherry R, Nuessly G. 2010. Repellency of the biopesticide, azadirachtin, to wireworms (Coleoptera: Elateridae). *Florida Entomologist* 93: 52–55.
- Cherry R, Stansly P. 2008. Abundance and spatial distribution of wireworms in Florida sugarcane fields on muck versus sandy soils. *Florida Entomologist* 91: 383–387.
- Cherry R, McCray M, Sandhu H. 2017. Changes in the relative abundance of soil-dwelling insect pests in Florida sugarcane. *Journal of Entomological Science* 52:169–176.
- Davis G. 1961. The biting response of larvae of the prairie grain wireworm, *Ctenicera aeripennis destructor* (Brown) (Coleoptera: Elateridae), to various extracts of germinating rye seed. *Canadian Journal of Zoology* 39: 299–303.
- Fenton F. 1926. Observations on the biology of *Melanotus communis* and *Melanotus pilosus*. *Journal of Economic Entomology* 19: 502–504.
- Gifford J. 1964. A brief review of sugarcane insect research in Florida, 1960–1964. *Proceedings of the Soil and Crop Science Society of Florida* 24: 449–453.
- Jansson R, LeCrone S. 1989. Evaluation of food baits for pre-plant sampling of wireworms in potato fields in southern Florida. *Florida Entomologist* 72: 503–510.
- Karounos M, Cherry R, Sandhu H, Otero C. 2018. Feeding behavior of *Melanotus communis* (Coleoptera: Elateridae) in Florida sugarcane. *Journal of Entomological Science* 53: 242–250.
- Keaster A, Chippendale G, Pill B. 1975. Feeding behavior and growth of the wireworms *Melanotus depressus* and *Limonius dubitans*: effect of host plants, temperature, photoperiod, and artificial diets. *Environmental Entomology* 4: 591–595.
- Norris R, Kogan M. 2000. Interactions between weeds, arthropod pests, and their natural enemies in managed ecosystems. *Weed Science* 48: 94–158.
- Odero D, Cherry R, Hall D. 2013. Weedy host plants of the sugarcane root weevil in Florida sugarcane. *Journal of Entomological Science* 48: 81–89.
- Quate L, Thompson S. 1967. Revision of click beetles of genus *Melanotus* in America North of Mexico (Coleoptera: Elateridae). *Proceedings of the United States National Museum* 121: 1–83.
- R Core Team. 2014. R: a language and environment for statistical computing. R Foundation for Statistical Computing, Vienna, Austria. <http://www.R-project.org/> (last accessed 19 Jan 2019).
- Riley T, Keaster A, Enns W. 1974. Species of wireworms of the genus *Melanotus* associated with corn in Missouri. *Journal of Economic Entomology* 67: 793. doi: 10.1093/jee/67.6.793
- Rott P, Odero D, Beuzelin J, Raid R, VanWeelden M, Mossler M. 2018. Florida crop/pest profile: sugarcane. Institute of Food and Agricultural Sciences, PI-171, University of Florida, Gainesville, Florida. <http://edis.ifas.ufl.edu/pi207> (last accessed 19 Jan 2019).
- Thorpe W, Crombie A, Hill R, Darrah J. 1947. The behavior of wireworms in response to chemical stimulation. *Journal of Experimental Biology* 23: 234–266.
- Traugott M, Benefer C, Blackshaw R, van Herk W, Vernon R. 2015. Biology, ecology and control of elaterid beetles in agricultural land. *Annual Review Entomology* 60: 313–334.
- van Herk W, Vernon R. 2007. Soil bioassay for studying behavioral responses of wireworms to insecticide-treated wheat seed. *Environmental Entomology* 36:1441–1449.
- VanWeelden M, Swanson S, Davidson W, Rice R. 2018. Sugarcane variety census: Florida 2017. *Sugar Journal*, July 2018: 10–19.
- Villani M, Gould F. 1985. Screening of crude plant extracts as feeding deterrents of the wireworm, *Melanotus communis*. *Entomologia Experimentalis et Applicata* 37: 69–75.