



A Three-Dimensional Fluorescence Analysis of the Wings of Male *Morpho sulkowskyi* and *Papilio xuthus* Butterflies

Authors: Kumazawa, Kinya, and Tabata, Hiroshi

Source: Zoological Science, 18(8) : 1073-1079

Published By: Zoological Society of Japan

URL: <https://doi.org/10.2108/zsj.18.1073>

BioOne Complete (complete.BioOne.org) is a full-text database of 200 subscribed and open-access titles in the biological, ecological, and environmental sciences published by nonprofit societies, associations, museums, institutions, and presses.

Your use of this PDF, the BioOne Complete website, and all posted and associated content indicates your acceptance of BioOne's Terms of Use, available at www.bioone.org/terms-of-use.

Usage of BioOne Complete content is strictly limited to personal, educational, and non-commercial use. Commercial inquiries or rights and permissions requests should be directed to the individual publisher as copyright holder.

BioOne sees sustainable scholarly publishing as an inherently collaborative enterprise connecting authors, nonprofit publishers, academic institutions, research libraries, and research funders in the common goal of maximizing access to critical research.

A Three-Dimensional Fluorescence Analysis of the Wings of Male *Morpho sulkowskyi* and *Papilio xuthus* Butterflies

Kinya Kumazawa* and Hiroshi Tabata

Materials Research Laboratory, Nissan Research Center, Nissan Motor Co.Ltd.,
1Natsushima-cho, Yokosuka 237-8523, Japan

ABSTRACT—Fluorescence properties from the wings of male *M. sulkowskyi* and *Papilio xuthus* butterflies were investigated for the first time over a wide range of excitation and emission wavelengths using a three-dimensional (3-D) fluorescence method.

From the 3-D plots of the pale blue region of the wings of *M. sulkowskyi*, four contour peaks were observed. On the other hand, from the yellow region of the wings of *Papilio xuthus*, one peak was observed. The origins of these contour peaks are discussed based on a comparison with standard pigments. Of the four contour peaks seen for *M. sulkowskyi*, a specific peak (A), located at an excitation wavelength of about 325 nm and an emission wavelength of about 410 nm, was thought to be mainly due to a mixture or compound of three pteridine pigments (i.e., biopterin, pterin and isoxanthopterin). The single specific peak observed for *Papilio xuthus*, located at an excitation wavelength of about 400 nm and an emission wavelength of about 470 nm, was thought to be due to the Papiliochrom II pigment.

Based on these results, the possibility of using 3-D fluorescence analysis as a tool for classifying butterflies is briefly described.

Key words: 3-D fluorescence, butterfly wing, classification, *M. sulkowskyi*, *P. xuthus*

INTRODUCTION

Butterflies are among the showiest of insects, and their beautiful wing colors have inspired centuries of study. Some species of *Morpho* butterflies in the family Nymphalidae (Ackery, 1984) are known to display typical structural colors (not pigment colors). Anderson and Richards (1942) investigated the correlation between color and structure in *M. cypris* by electron microscopy and reported that the brilliant blue color of this butterfly is based on the microscopic structure of the wing scales. Following their work, attempts at more quantitative correlations of structure and color have been concentrated on *Morpho* species such as *M. cypris* (Ghiradella, 1972, 1984; Wright, 1963), *M. menelaus* (Ghiradella, 1984, 1976), and *M. amathonte* (Ghiradella, 1984). In addition to these observations, we have also recently reported our findings concerning the correlation between the color and structure of the wings of *Morpho* species such as *M. sulkowskyi* and *M. adonis* (Tabata *et al.*, 1996).

Since the pioneering work of Cockayne (1924), on the

other hand, it has been reported that the wings of some butterflies in the family *Papilionidae* (Umebachi, 1970, 1985; Shono, 1983) and in the family *Pieridae* (Shono, 1983; Ford, 1941, 1944, 1947) emit fluorescence. Cockayne proposed that an examination of the fluorescent pigments in butterfly wings might be useful for the classification of these butterflies. Compared with studies on the fluorescence of *Papilionidae* and *Pieridae* butterflies, the emission of fluorescence from the wings of *Morpho* species had never been reported until our recent work (Kumazawa *et al.*, 1994, 1996; Kumazawa and Tabata, 1996; Tabata *et al.*, 1996). In 1994, we investigated the fluorescence emitted from various parts of the wings of male *M. sulkowskyi* butterflies using a microspectrophotometer (MSP) and reported for the first time that the pale blue region of the wings was fluorescent when irradiated with ultraviolet (UV) or visible light, but the black region was nonfluorescent and that the fluorescence spectra from the upper and lower surfaces of the scales differed (Kumazawa *et al.*, 1994). Additionally, pigments responsible for the fluorescence spectra were identified using high-performance liquid chromatography (HPLC), high-performance thin-layer chromatography (HPTLC) and ultraviolet (UV) spectroscopy, with the result that three pteridine pigments (biopterin, pterin and isoxanthopterin) were present in the wings (Tabata *et al.*, 1996).

* Corresponding author: Tel. 0468-67-5194;
FAX. 0468-67-1505.
E-mail: k-kumazawa@mail.nissan.co.jp

The objective of this work was to provide a useful technique for the classification of butterflies by a nondestructive and easy-to-use method. We undertook a characterization of the fluorescence properties of the wings of male *M. sulkowskyi* and *P. xuthus* butterflies over a wide range of excitation and emission wavelengths using a three-dimensional (3-D) fluorescence method. From the 3-D plots for the wings of *M. sulkowskyi* and *P. xuthus*, four specific peaks and one contour peak were clearly observed, respectively. The origins of these contour peaks are discussed based on a comparison with standard pigments.

Of the four contour peaks seen for *M. sulkowskyi*, one specific peak (A), located at an excitation wavelength of about 325 nm and an emission wavelength of about 410 nm, was thought to be mainly attributable to a mixture or compound of three pteridine pigments (i.e., biopterin, pterin and isoxanthopterin). On the other hand, the one specific peak observed for *P. xuthus*, located at an excitation wavelength of about 400 nm and an emission wavelength of about 470 nm was thought to be caused by the Papiliochrome II pigment.

Based on these results, the possibility of using 3-D fluorescence analysis as a tool for classifying butterflies is briefly described.

MATERIALS AND METHODS

Materials and preparations

The wings of male *M. sulkowskyi* and *P. xuthus* butterflies were purchased from Okura Biological Lab. (Tokyo, Japan), as mentioned

in our previous papers. Several kinds of standard fluorescent pigments such as biopterin, pterin and isoxanthopterin were used for specification of the pigments responsible for the fluorescence emitted from *M. sulkowskyi*. The pigments were supplied by Dr. B. Shircks Laboratories (Jona, Switzerland) and were selected because it has been suggested that they might be present in the wings of this butterfly.

Fluorescence has been observed only from the pale blue and yellow regions of the wings of *M. sulkowskyi* and *P. xuthus*, as indicated in our previous paper (Kumazawa *et al.*, 1994). Therefore, this investigation also focused on the pale blue and yellow regions of the wings. That was done by removing the wings from the body with a cutter and mounting them on nonfluorescent quartz glass (Matsunami Glass Co., Tokyo, Japan) for analysis. Fluorescence from the powders of the standard pigments was analyzed using a specific holder with the quartz glass (Hitachi, model 650-0161).

Apparatus

All fluorescence measurements were made using an F-4500 Hitachi fluorescence spectrophotometer (Hitachi, Ltd., Tokyo, Japan). A diagram of this apparatus is shown in Fig. 1.

The light emitted by a 150-watt xenon lamp (L) is introduced into an excitation monochromator (EXM) that selects light of certain specified wavelengths and outputs it to a beam splitter (BS) from which a portion of the light irradiates the sample (SA). A portion of the light is also introduced into a monitor detector (MD). Fluorescence produced by the sample is introduced into an emission monochromator (EMM) that selects light of certain desired wavelengths. The selected light is then introduced into a photomultiplier tube (PMT) that measures the light intensity. The output of the PMT is divided by the monitor detector (MD), and the value thus obtained is used in correcting the quantity of light emitted by the light source. A shutter (S) is provided between the beam splitter (BS) and the sample (SA) to block the excitation light except during the data acquisition interval.

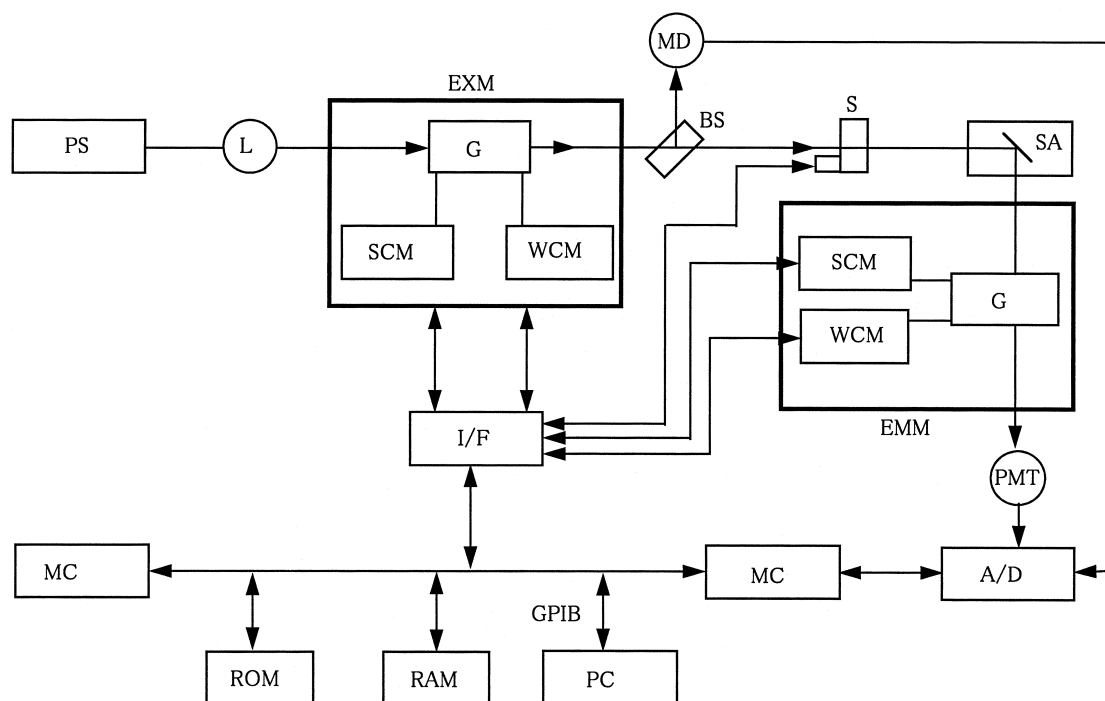

Fig. 1. Diagram of the setup for measuring the three-dimensional fluorescence property, F-4500 (Hitachi, Ltd., Tokyo). A/D: analog-to-digital converter, BS: beam splitter, EMM: emission monochromator, EXM: excitation monochromator, G: grating, GCM: grating control motor, GPIB: general purpose interface bus, I/F: interface, L: xe-lamp, MC: microcomputer, MD: monitor detector, PC: personal computer, PMT: photo multiplier tube, PS: power source, RAM: random access memory, ROM: read only memory, S: shutter, SA: sample, SCM: slit control motor,

The maximum scan speed of this apparatus is 30,000 nm/min (500 nm/s) and the minimum data sampling interval is 0.001 s. A powerful and faster pulsed motor in the wavelength drive mechanism, and two microcomputers (one is dedicated to data acquisition from a photo multiplier tube (PMT)) are used to achieve the rapid scan. This apparatus can acquire a spectrum within 1 second, and it takes about only 1 min to get 3-D data.

A description is given here of the specific measurement conditions that were used. To reconfirm fluorescence from the wings of the butterflies, 3-D measurements were mainly carried out at excitation wavelengths ranging from 200 to 400 nm and at emission wavelengths ranging from 300 to 500 nm. A scan speed of 12,000 nm/min and a data sampling interval of 0.001 s were used in this experiment. The spectral bandwidth of the excitation and emission monochromators was 5.0 nm.

Irradiation was done at a 60-degree angle to the sample surface and fluorescence was collected at a 30-degree angle to the surface. The irradiated area on a sample through the rectangular slit was about 5 mm² (1 mm × 5 mm). To avoid photodegradation of the butterfly wing samples, an automated shutter system was used to open the shutter only when data were being collected.

The fluorescence data presented here have been corrected for the nonuniform spectral response of the detection system using the correction factors supplied with the instrument. Fluorescence measurements were carried out at room temperature.

RESULTS AND DISCUSSION

Fluorescence from the wings

Compared with conventional fluorescence measurements, a 3-D fluorescence measurement (Petzick and Froehlich, 1992; Shimoyama and Noda, 1992, 1993; Zeng *et al.*, 1995; Barnes *et al.*, 1993) provides all of the desired information such as the excitation wavelength, emission wavelength and fluorescence intensity.

This information is obtained as the top ring of contour lines connecting points of equal fluorescence intensity. Thus, the contour plot has a pattern specific to each sample much like a fingerprint. Therefore, in addition to the MSP technique described previously (Kumazawa *et al.*, 1994, 1996) we thought that this approach might be used to identify small differences among similar samples or unknown samples by comparison with standard samples. Based on this idea, we investigated for the first time the fluorescence from butterfly wings using the 3-D fluorescence method.

3-D plot for wings of *M. sulkowskyi*

Fig. 2 shows the 3-D contour plot obtained from the pale blue region of the wings of a male *M. sulkowskyi*. Some contour peaks (i.e., center of the circles) and two diagonal lines are observed. The two diagonal lines running from the top of the figure to the bottom left indicate the first-order (i.e., the emission wavelengths are equal to the excitation wavelengths) and second-order (i.e., the emission wavelengths are equal to two times the excitation wavelengths) scatterings of excitation light. Of the contour peaks mentioned above, peak B at an excitation wavelength of about 310 nm and an emission wavelength of about 330 nm and peak F at excitation and emission wavelengths of about 225 nm and 340 nm, respectively, show a valley (ex., see Fig. 3 (a)). In contrast, four other

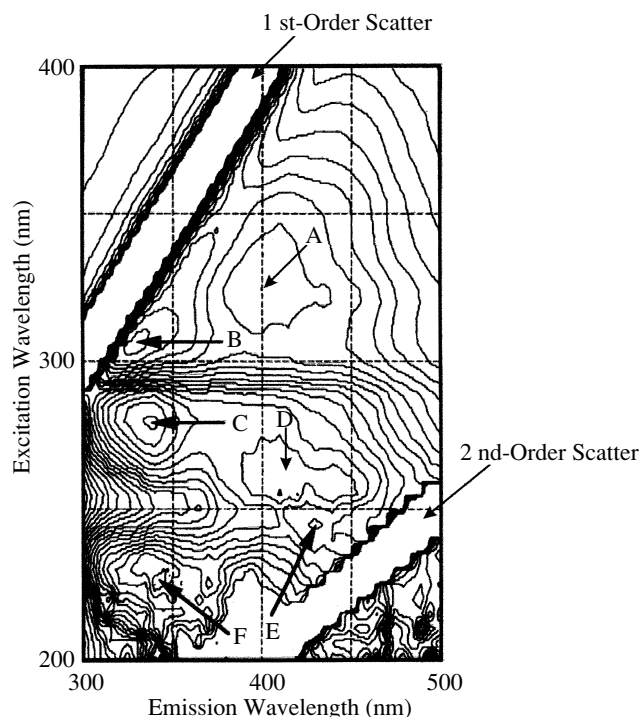

Fig. 2. Three-dimensional contour plot obtained from the pale blue region of the wings of a male *M. sulkowskyi*. In this figure, A, C, D and E show the contour peaks. B and F show the valley (not contour peaks).

contour peaks (A, C, D and E) give the top ring of the contour line responsible for the fluorescence.

Contour peak A is observed at an excitation wavelength of about 325 nm and an emission wavelength of about 410 nm. Contour peak C is observed at excitation and emission wavelengths of about 280 nm and 340 nm, respectively. Contour peaks D and E are observed at an excitation wavelength of about 255 nm and an emission wavelength of about 410 nm and at an excitation wavelength of about 250 nm and an emission wavelength of about 430 nm, respectively. In the pale blue region of the wings of male *M. sulkowskyi*, therefore, it is thought that at least four kinds of fluorescent pigments or compounds corresponding to the four observed contour peaks are present.

In other words, the wings of male *M. sulkowskyi* have their own distinctive 3-D data (contour peak number and specific excitation and emission wavelengths).

This result may characterize the wings of male *M. sulkowskyi*.

The emission spectra were then analyzed to investigate the origin of the fluorescent pigments or compounds corresponding to these four contour peaks (i.e., A, C, D and E). Fig. 3 (b)–Fig. 3 (e) show the emission spectra of the four contour peaks when the best excitation wavelength was used. The emission spectra at different excitation wavelengths are very different in both shape and intensity. These results also support the idea that at least four kinds of fluorescent pigments or compounds are present in the wings of this butterfly.

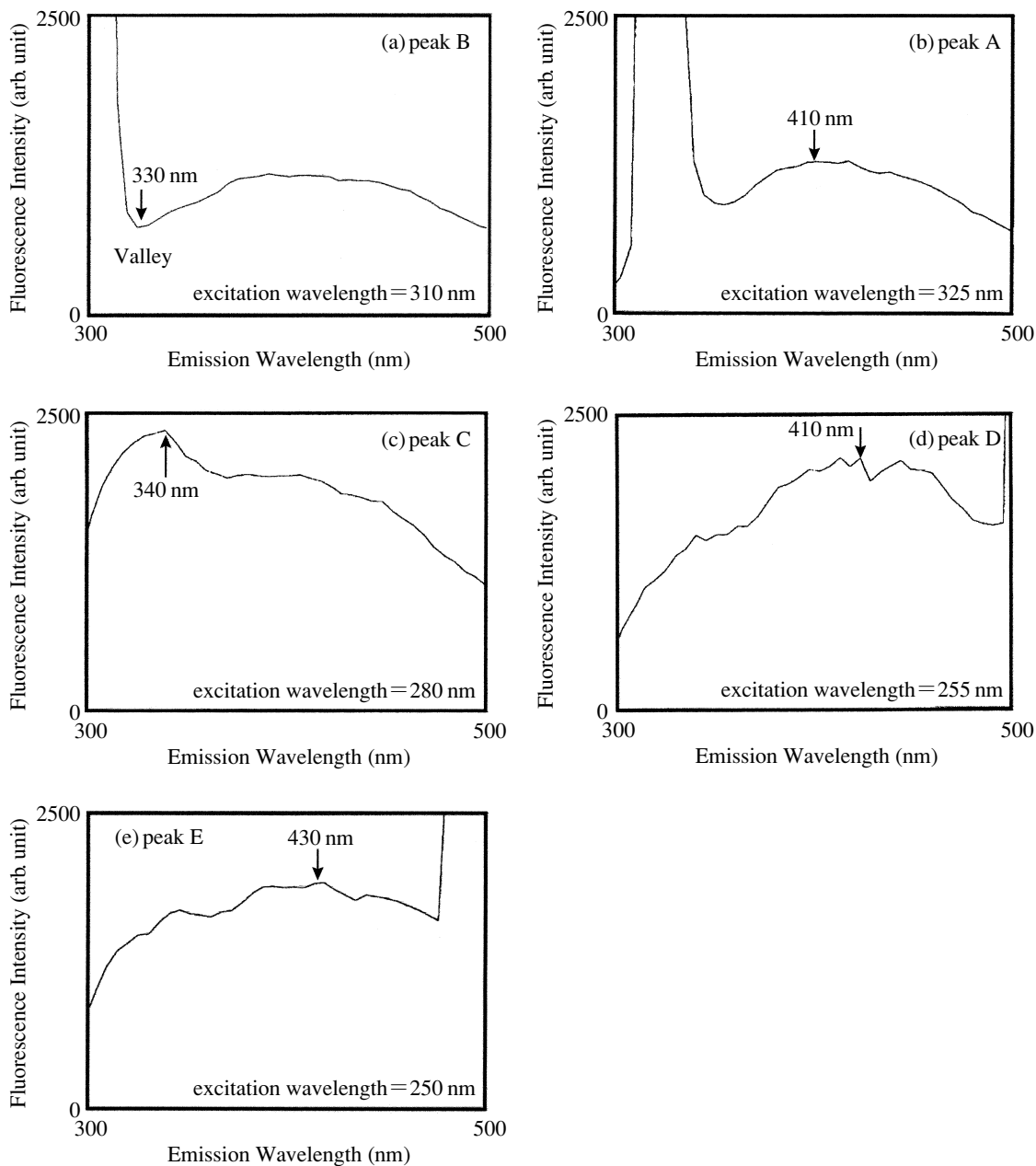

Fig. 3. (a) Emission spectrum obtained from contour peak B. The excitation wavelength was 310 nm.
Fig. 3. (b) Emission spectrum obtained from contour peak A. The excitation wavelength was 325 nm.
Fig. 3. (c) Emission spectrum obtained from contour peak C. The excitation wavelength was 280 nm.
Fig. 3. (d) Emission spectrum obtained from contour peak D. The excitation wavelength was 255 nm.
Fig. 3. (e) Emission spectrum obtained from contour peak E. The excitation wavelength was 250 nm.

3-D plot for wings of *P. xuthus*

As an example of another species of butterfly, we investigated the 3-D plot from the yellow region of the wings of a male *P. xuthus*. Fig. 4 shows the contour plot obtained from this butterfly. A contour peak is observed at an excitation wavelength of about 400 nm and an emission wavelength of about 470 nm. The emission spectrum obtained from this contour plot is shown in Fig. 5.

Judging from the results of our previous study (Kumazawa *et al.*, 1996) and Shono's paper (1983) on the fluorescent pig-

ment in the wings of *P. xuthus*, the origin of this peak is thought to be due to the Papiliochrome II pigment.

According to Umehachi (1978, 1985), the Papiliochrome II pigment is also present in the yellow region of the wings of male *P. demoleus*, *P. protenor* and *P. dardanus* in the family Papilionidae. Therefore, similar contour peaks attributable to the Papiliochrome II pigment might also be observed in species other than *P. xuthus*, though this has not yet been examined.

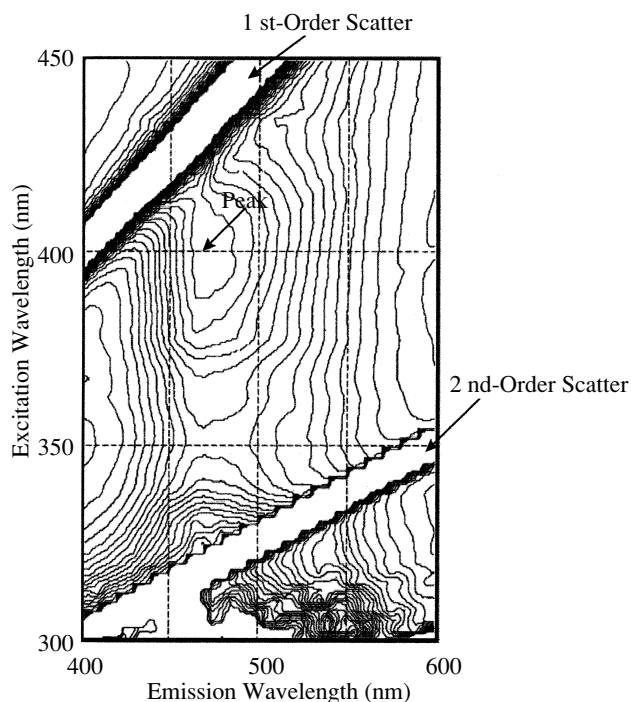

Fig. 4. Three-dimensional contour plot obtained from the yellow region of the wings of a male *P. xuthus*.

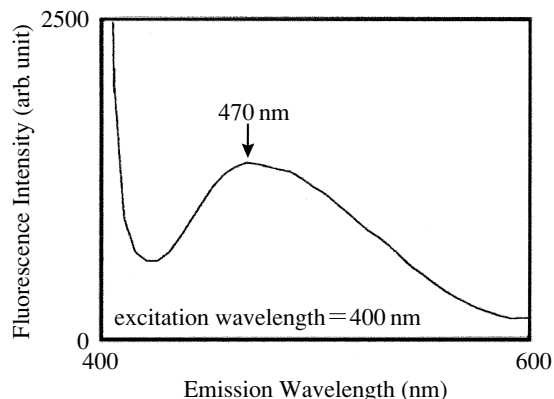

Fig. 5. Emission spectrum obtained from the contour peak shown in Fig. 3. The excitation wavelength was 400 nm.

Fluorescence from pteridine pigments

In our previous studies on the fluorescent pigments present in the wings of male *M. sulkowskyi* using HPLC, pteridine pigments such as biopterin, pterin and isoxanthopterin and unknown pigments were found (Tabata *et al.*, 1996). The average contents of biopterin, pterin and isoxanthopterin in the wings of this butterfly were $1,030 \pm 430$, 459 ± 183 and 150 ± 57 pmol/specimen, respectively.

The chemical properties of the pteridine pigments in the wings and/or the scales differed from those of the dry powder samples (standard pteridine pigments). However, measurements of the UV spectrum, which provide information about the electronic state of the material as in the fluorescence study, of the pterin solution (Pfleiderer, 1985) made it possible to

estimate that the difference in the fluorescence peak position between the dry powder samples and the pigments in the wings was less than approximately 20 nm.

Therefore, we investigated the fluorescence from the dry powder samples of three kinds of pteridine pigments

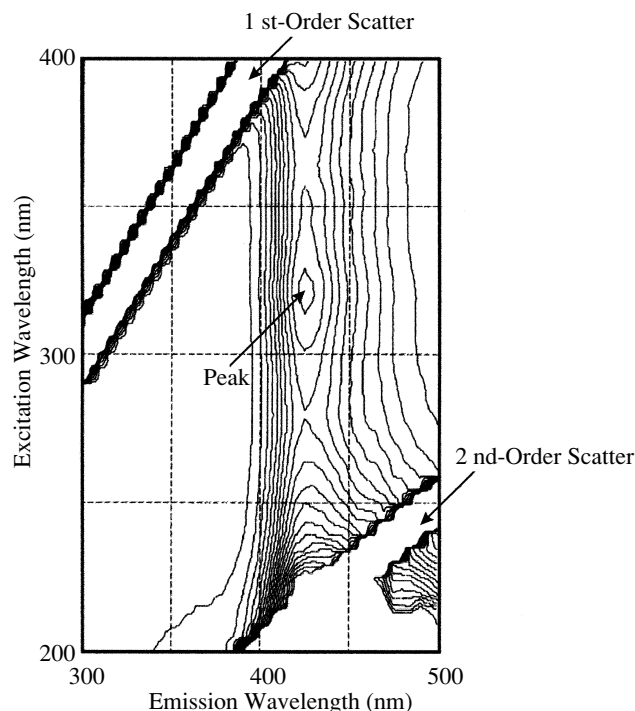

Fig. 6. Three-dimensional contour plot obtained from the standard biopterin pigment (powder).

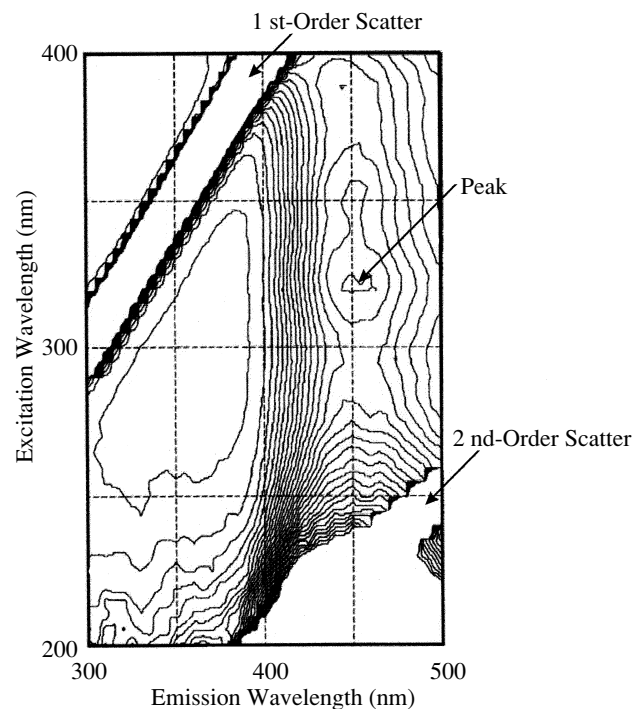

Fig. 7. Three-dimensional contour plot obtained from the standard pterin pigment (powder).

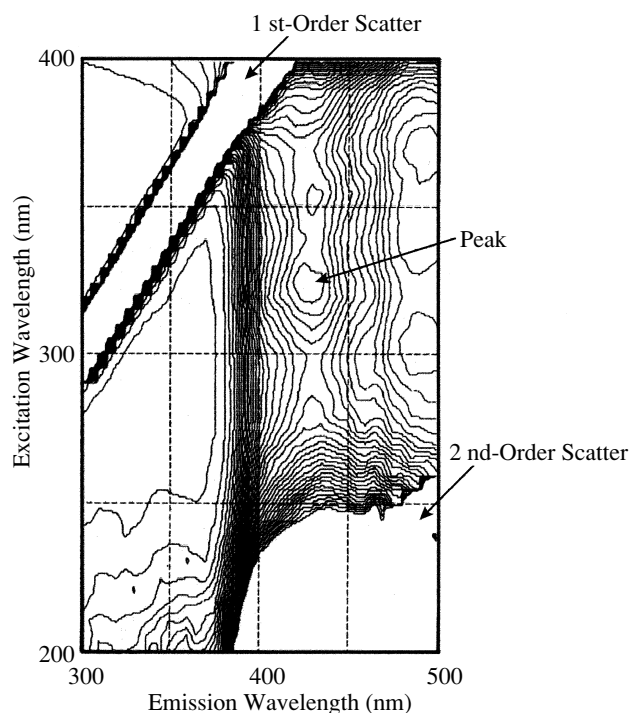

Fig. 8. Three-dimensional contour plot obtained from the standard isoxanthopterin pigment (powder).

(biopterin, pterin and isoxanthopterin). The 3-D contour plots obtained from these pteridine pigments are shown in Fig. 6 to Fig. 8.

The contour peaks from the biopterin, pterin and isoxanthopterin powders are seen at excitation and emission wavelengths of about 320 nm and 425 nm, 320 nm and 450 nm, and 325 nm and 430 nm, respectively. Thus, the position of the contour peaks (i.e., excitation-emission wavelengths) from the biopterin and isoxanthopterin pigments was very similar to that of contour peak A from the wings of male *M. sulkowskyi*.

In contrast, the contour peak position from the pterin pigment was slightly different from that of contour peak A in Fig. 2. This difference may be due to a difference in the electronic state between pterin and the other two pteridine pigments (i.e., biopterin and isoxanthopterin) in the wings of this butterfly.

It is generally known that the pteridine pigments in the wings or scales of butterflies are weakly bonded to surrounding proteins (Pfleiderer, 1985).

Therefore, it is not surprising that there was a small difference in contour peak position between the dry powder samples and the pigments in the wings. These results suggest that contour peak A seen in Fig. 2 may have been derived from a mixture or compound of these three pteridine pigments. This would also explain the complexity of the shape of contour peak A, which resembles the composition of two peaks.

To clarify the origin of the other three contour peaks (C, D and E), we investigated 3-D contour plots thought to contain some pteridine pigments such as leucopterin, xan-

thopterin and neopterin. However, contour peaks of pteridine pigments corresponding to peaks C, D and E were not found. Further investigation is now under way to clarify the origin of these three contour peaks.

Possible tool for the classification of butterflies

In addition to studying the fluorescence from the wings of male *M. sulkowskyi*, more recently, we also investigated the fluorescence from the blue region of the wings of male *M. Adonis* using this method. In a manner similar to the results seen for *M. sulkowskyi*, some contour peaks were observed and one of them was rather consistent with the position of contour peak A in Fig. 2 (Kumazawa, unpublished). Both species of butterfly had their own pattern of specific circles at around the position of contour peak A (at excitation and emission wavelengths of about 325 nm and 410 nm, respectively), much like a fingerprint.

According to our previous studies using HPLC, three pteridine pigments (biopterin, pterin and isoxanthopterin) were also found in the wings of *M. Adonis* (Tabata *et al.*, 1996). If specific fluorescent pigments or compounds are contained in the wings of butterflies, these results suggest that this technique of using 3-D fluorescence analysis might be a useful tool for classifying butterflies.

The same fluorescent pigments are actually present in the wings of *M. sulkowskyi* and *M. Adonis*, so it would not be surprising for both of these butterflies to belong to the same family or subfamily.

According to Ackery (1984), *M. sulkowskyi* and *M. Adonis* belong to the same subfamily (Morphinae). Therefore, our conclusion regarding the classification of butterflies based on the position of contour peaks obtained from the 3-D fluorescence measurements would not be inconsistent with his classification.

As to taxonomic studies of butterflies, various methods such as morphological (Ghiradella, 1984, 1974; Downey, 1975), chemical (Umebachi, 1970; Descimon, 1975, 1965) and genetic (Turner, 1981) analyses have been employed.

However, in many cases, these methods are destructive and involve complicated experimental procedures. Compared with these methods, an analysis of contour peaks using the 3-D fluorescence method can be made rather easily and in a nondestructive manner. Such an analysis yields information about the numbers and kinds of fluorescent pigments or compounds in the wings of butterflies based on their characteristic pattern resembling a fingerprint. Therefore, this method could be a useful tool for the classification of butterflies, though much more data from other butterflies are necessary.

Possibility for zoological applications of 3-D fluorescence analysis

The butterfly wings mentioned in the foregoing discussion were all dry samples. Therefore, in an effort to investigate the possibility of applying 3-D fluorescence analysis to zoology, we have recently obtained living male *P. xuthus* and have performed fluorescence analyses on the yellow region

of the wings, as mentioned earlier, of living butterflies.

It was expected that differences in the water content or the combinations of fluorescent pigments present in the wings, among other factors, would influence the position of the contour peak which was obtained by the 3-D fluorescence method.

However, the contour peak position was observed at an excitation wavelength of about 400 nm and an emission wavelength of about 470 nm, which was the same as that seen for the dry samples described earlier. These results suggest that it is possible that the characteristics of the fluorescent pigments present in the wings or scales of butterflies do not change appreciably regardless of whether a butterfly is alive or dead.

This is the first known application of 3-D fluorescence analysis to living animals. Although not enough data have been collected at this point, it is possible that this method may have latent potentialities that might lead to new developments in the future.

It is also possible that, by combining the 3-D fluorescence spectrophotometer with a microscope, optical fiber or some other apparatus in the future, new information about fluorescence, ranging from the microscopic to the macroscopic domain, might be obtained from living animals regardless of their size.

ACKNOWLEDGEMENTS

The authors would like to thank Dr. O. Yata of Kyushu University (Fukuoka, Japan) for his suggestions on taxonomy. The authors are also grateful to Mr. C. Jindoh and Mr. N. Obara of Nissei Sangyo Co., Ltd., and Mr. H. Koshi of Hitachi, Ltd. for their helpful advice and use of the fluorescence spectrophotometer.

REFERENCES

- Ackery PR (1984) Systematic and Faunistic Studies on Butterflies. In "the Biology of Butterflies". Ed by RI Vane-Wright, PR Ackery, Academic Press, London, pp 9–21
- Anderson TF, Richards AG Jr (1942) An electron microscope study of some structural colors of insects. *J Appl Phys* 13: 748–758
- Barnes D, Aggarwal S, Thomsen S, Fitzmaurice M, Richards-Kortum R (1993) A characterization of the fluorescent properties of circulating human eosinophils. *Photochem Photobiol* 58: 297–303
- Cockayne EA (1924) The distribution of fluorescent pigments in Lepidoptera. *Trans Ent Soc Lond (A)* Pst 1: 1–19
- Descimon H (1975) Chemistry and Biology of Pteridines. *Pro 5th Intl Symp Konstanz Walter de Gruyter*, New York, pp 805–840
- Descimon H (1965) Ultrastructure et pigmentation des écailles des Lépidoptères. *J Microscopie* 4: 130
- Downey JC, Allyn AC (1975) Wing-scale morphology and nomenclature. *Bull Allyn Mus* 31: 1–30
- Ford EB (1941) Studies on the chemistry of pigments in the Lepidoptera, with reference to their bearing on systematics. *Proc R Ent Soc Lond (A)* 16: Pst 7–9: 65–90
- Ford EB (1944) Studies on the chemistry of pigments in the Lepidoptera, with reference to their bearing on systematics 4. The classification of the Papilionidae. *Trans Ent Soc Lond* 94 Part 2: 201–223
- Ford EB (1947) A murexide test for the recognition of pteridines in intact insect. *Pro R Ent Soc Lond (A)* 22: 72–76
- Ghiradella H, Aneshensleg D, Eisner T, Silberglied R, Hinton HE (1972) Ultraviolet reflection of a male butterfly: interference color caused by thin-layer elaboration of wing scales. *Science* 178: 1214–1217
- Ghiradella H (1974) Development of ultraviolet-reflecting butterfly scales: how to make interference filter. *J Morphol* 142: 395–410
- Ghiradella H (1984) Structure of iridescent butterfly scales. Variations on several themes. *Ann Entomol Am* 77: 637–645
- Ghiradella H, Radigan (1976) Development of butterfly scales II. Struts, lattices, and surface tension. *Ann Entomol Am* 150: 279–298
- Kumazawa K, Tanaka S, Negita K, Tabata H (1994) Fluorescence from wing of *Morpho sulkowskyi* butterfly. *Jpn J Appl Phys* 33: 2119–2122
- Kumazawa K, Negita K, Hasegawa T, Tabata H (1996) Fluorescence from cover and basal scales of *Morpho sulkowskyi* and *Papilio xuthus* butterflies. *J Exp Zool* 275: 15–19
- Kumazawa K, Tabata H (1996) Time-resolved fluorescence studies of the wings of *Morpho sulkowskyi* and *Papilio xuthus* butterflies. *Zool Sci* 13: 843–847
- Petzick MP, Froehlich PM (1992) Extending the capability of luminescence spectroscopy with a rapid-scanning fluorescence spectrophotometer. *American Laboratory* 68–73
- Shimomura S, Noda Y (1992) Non-destructive determination of natural dyestuffs used for ancient coloring cloth by the three-dimensional fluorescence spectrum. *Bunseki Kagaku* 41: 243–250 (in Japanese)
- Shimoyama S, Noda Y (1993) Non-destructive determination of natural dyestuffs used for a ancient colored cloths using a three-dimensional fluorescence spectrum technique. *Pro 12th Int Conf., Dyes in history and archeology*, Brussels Textile Research Associates York, 1994 pp 45–56
- Shono M (1983) Examination of squama in spring type butterfly by microfluorespectrophotometry. *Med boil* 107 (3): 121–123 (in Japanese)
- Tabata H, Kumazawa K, Funakawa M, Takimoto J, Akimoto M (1996) Microstructure and optical properties of scales of butterfly wings. *Opt Rev* 3: 139–145
- Tabata H, Hasegawa T, Nakagoshi M, Tsusue M (1996) Occurrence of biopterin in the wings of *Morpho sulkowskyi*. *Experientia* 52: 85–87
- Turner JRG (1981) Adaptation and evolution in *Helicocus* butterflies. *Ann Rev Ecol Syst* 12: 99–121
- Umehachi Y, Yoshida K (1970) Some chemical and physical properties of papiliochrome II in the wings of papilio xuthus. *J Insect Physiol* 16: 1203–1228
- Umehachi Y (1975) Yellow pigments in the wings of Papilio xuthus (Papilionid Butterfly). *Acta Vitamine Enzymol* 29: 219–222
- Umehachi Y (1985) Papiliochrome, a new pigment group of butterfly. *Zool Sci* 2: 163–174
- Wright WD (1963) The rays are not colored. *Nature* 198: 1239–1244
- Zeng H, Macaulay C, Malleau D, Palcic B (1995) Spectroscopic and microscopic characteristics of human skin autofluorescence emission. *Photochem Photobiol* 61: 639–645

(Received May 23, 2001 / Accepted August 27, 2001)