

Phenotypic variation and polymorphism confirmed among white-bellied swiftlets of the *Collocalia esculenta* group (Apodidae, Collocaliini) by mitochondrial and nuclear DNA evidence

Authors: Davies, Sian E. W., Goh, Wei Lim, Ball, Sarah P., Siew, Wei Sheng, and Tarburton, Michael

Source: Bulletin of the British Ornithologists' Club, 140(4) : 373-386

Published By: British Ornithologists' Club

URL: <https://doi.org/10.25226/bboc.v140i4.2020.a2>

BioOne Complete (complete.BioOne.org) is a full-text database of 200 subscribed and open-access titles in the biological, ecological, and environmental sciences published by nonprofit societies, associations, museums, institutions, and presses.

Your use of this PDF, the BioOne Complete website, and all posted and associated content indicates your acceptance of BioOne's Terms of Use, available at www.bioone.org/terms-of-use.

Usage of BioOne Complete content is strictly limited to personal, educational, and non - commercial use. Commercial inquiries or rights and permissions requests should be directed to the individual publisher as copyright holder.

BioOne sees sustainable scholarly publishing as an inherently collaborative enterprise connecting authors, nonprofit publishers, academic institutions, research libraries, and research funders in the common goal of maximizing access to critical research.

Phenotypic variation and polymorphism confirmed among white-bellied swiftlets of the *Collocalia esculenta* group (Apodidae, Collocaliini) by mitochondrial and nuclear DNA evidence

Sian E. W. Davies*, Wei Lim Goh*, Sarah P. Ball, Earl of Cranbrook, Wei Sheng Siew & Michael Tarburton

Received 29 December 2016; resubmitted 3 December 2018; revised 25 September 2020; published 9 December 2020

<http://zoobank.org/urn:lsid:zoobank.org:pub:3826C787-5FC7-4863-BF0F-251EC206A1E0>

SUMMARY.—Among white-bellied glossy swiftlets of the *Collocalia* group, A. R. Wallace was first to recognise the Makassar Strait, separating Borneo and Sulawesi, as a geographical barrier between different phenotypes: plain-tailed to the west and spot-tailed to the east. Other morphological characters used to define species within the group have been blue or green gloss to the dorsal plumage, and the presence or absence of a single minute tufted feather on the hallux. The value of these characters as taxonomic markers is now known to be unreliable due to the discovery of phenotypically mixed populations east of the Makassar Strait, from North Maluku province, Indonesia, through Papua New Guinea to New Ireland. We combine field observations of plumage characters with genetic evidence to establish taxonomy of *Collocalia* group swiftlets. Sequencing specific mitochondrial genes (*Cytb* and *ND2*), the nuclear-encoded *Fib* gene, and a subset of mitochondrial genomes provided data for phylogenetic analysis. Genetic divergence of *c.*4.7% is observed between two *Collocalia* clades either side of the Makassar Strait: the plain-tailed *C. affinis cyanoptila* sampled at Fraser's Hill, Peninsular Malaysia, and a phenotypically mixed population of *C. esculenta spilura* from North Maluku, Indonesia. Each population formed high-affinity genetic clades, within which divergence was <0.5%. These findings are consistent with geographic but not phenotypic separation between populations. We therefore conclude taxonomy based on these plumage features in glossy swiftlets of the Collocaliini is unreliable.

Reviewers of the complex of small, white-bellied glossy swiftlets, for which the oldest available name is *Collocalia esculenta* (Linnaeus, 1758), have given weight to certain phenotypic characters as taxonomic indicators distinguishing species or species groups. One character, first perceived by Wallace (1864), separates 'plain-tailed' and 'spot-tailed' species. The plain-tailed group occurs from the Andaman Islands, India, through Malaysia and Indonesia to Lombok. All members have glossy upperparts that are uniformly dark-coloured including the rump and tail. 'Spot-tailed' populations, from Sulawesi east through and beyond New Guinea, were believed by Wallace (1864), and thereafter by Stresemann (1940) and Somadikarta (1982, 1986), to be differentiated by a white spot on the concealed inner vane of all but the central pair of rectrices. In a review of speciation in the *C. esculenta* complex integrating phenotypic and molecular data, Rheindt *et al.* (2017) broadly confirmed Wallace's ideas, with some revision of species boundaries within these two groups.

*The two first-named authors contributed equally to this work.



Figure 1. The minute feather tuft on the hallux of *Collocalia affinis cyanoptila* (Earl of Cranbrook)

Among the plain-tailed group of white-bellied swiftlets a second indicator is variation in the green or blue tone to the glossy upperparts. This character has been linked to the presence or absence of a single, small tufted feather on the dorsal side of the hind toe (hallux). Within the western plain-tailed white-bellied swiftlets, excluding those populations in the Philippines, two species groups have been separated by this mix of characters (Somadikarta 1982, 1986). One consists of the species *C. a. affinis* (*sensu* Rheindt *et al.* 2017) on the Andamans, Nicobar and other islands, and *C. a. cyanoptila* from Sumatra, Peninsular Malaysia and Borneo. Within this group, members of three geographically separated colonies of *C. a. cyanoptila* in Selangor, Peninsular Malaysia, exhibited individual age- and wear-related change, from the greenish gloss of fresh plumage to blue gloss of old, worn plumage. Although differently glossed, all individuals in the separate populations were genetically uniform (Lim 1994). Members of this group bear a single, very small tufted feather on the hallux (Fig. 1). In the live bird, this feather is moulted around mid-term during primary moult in the wings, and for a period may be totally absent from one foot or both or, if present, sheathed and inconspicuous (Cranbrook *et al.* 2005). It can also be difficult to confirm presence or absence of this feather on the hallux in specimens. The feet (often tied together) must be separated to allow inspection with a lens, and are often in poor condition due to fungal infestation or other issues of imperfect preservation.

The other group within the western plain-tailed population includes *C. linchi* of Java, Bali, Lombok and intervening small islands. These birds are characterised by permanently green-glossed upperparts including the tail, and being invariably 'bare-toed', i.e., lacking the feather tuft on the hallux. There is more than one instance of sympatry involving the *C. linchi* superspecies and *C. affinis*. In Sabah, Malaysia, the endemic *C. dodgei*, a member of the *linchi* superspecies (Rheindt *et al.* 2017), overlaps in daily activity range with the more numerous local population of *C. affinis cyanoptila* (Cranbrook *et al.* 2005, Moyle *et al.* 2008). On Sumatra, Somadikarta (1986) reported overlapping ranges of *C. affinis cyanoptila* and *C. linchi ripleyi*, with a mixed colony in a cave at Talangpadang, South Lampung. Separation at species level is confirmed by divergence in *Cytb* mtDNA sequences of 6.03–7.20% (Table 3 in Rheindt *et al.* 2017).

On the grounds of exhibiting a spotted tail, Christmas Island white-bellied swiftlet *C. natalis* was regarded by Stresemann (1940) and Somadikarta (1986) as a geographically anomalous member of the *C. esculenta* group, lying west of the main boundary of separation, named 'Stresemann's Line' by Somadikarta (1986) (Fig. 2). However, mitochondrial *Cytb* sequence divergence from nominate *linchi*, at 1.10–1.45%, is 'shallow' and this island endemic, which displays a morphology unlike any other *Collocalia* species, was considered a member of the *linchi* superspecies (Rheindt *et al.* 2017). Removal of *C. natalis* restores Wallace's concept of the Makassar Strait as a natural boundary between western plain-tailed and eastern spot-tailed white-bellied swiftlets. Molecular studies support divergence

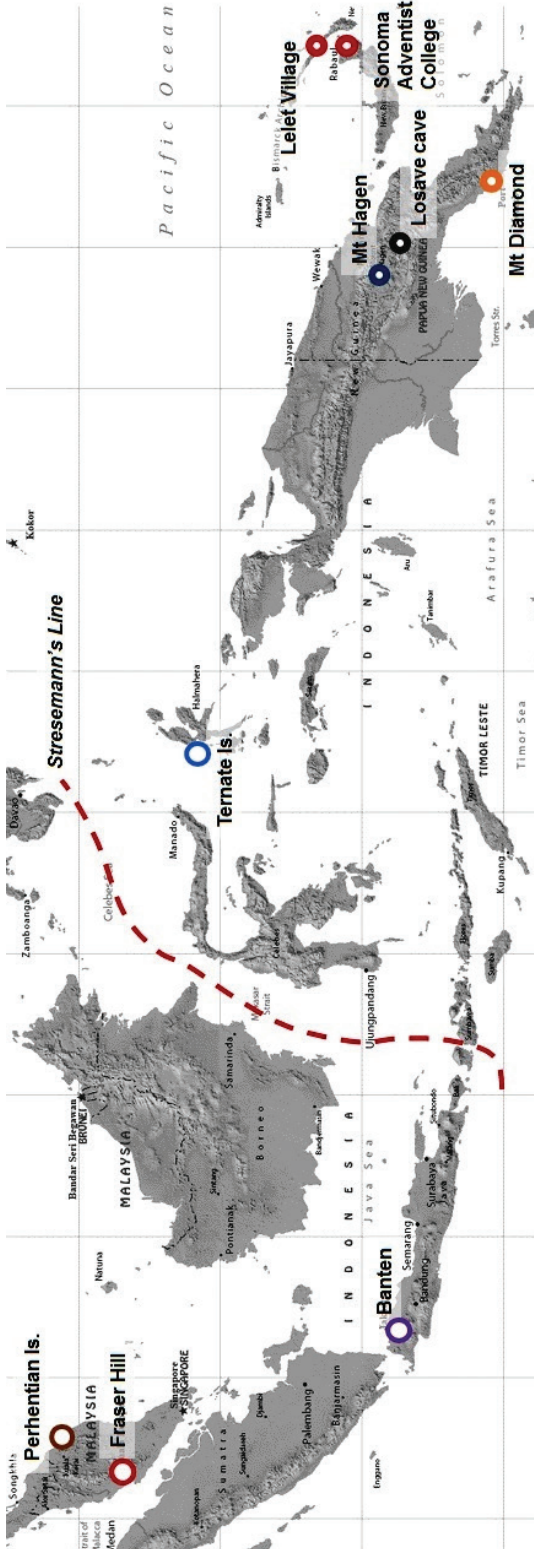

Figure 2. Locations where field observations and DNA material collection were undertaken, showing ‘Stresemann’s Line’ as defined by Somadikarta (1986).

between the clades separated by this boundary at 4.66–8.59% in mtDNA, regarded as ‘deep’ by Rheindt *et al.* (2017).

The possibility that plain-tailed white-bellied swiftlets might cross this boundary was raised by Mayr & Camras (1938); who noted a specimen of a plain-tailed, greenish-glossed, ‘apparently young’ bird resembling *C. linchi* of Lombok, among spot-tailed, blue-glossed *C. esculenta manadensis* on Sangihe (Sangir) Island, Sulawesi (also discussed by Salomonsen 1983: 31). S. Somadikarta (*in* Cranbrook *et al.* 2005) examined six additional specimens from Sangihe in the Bogor Zoological Museum, all of which had spotted tails. Rheindt *et al.* (2017) did not assess the implications of this single plain-tailed specimen east of Stresemann’s Line, but did report a personal communication by Cranbrook, with photographs of four individuals at a single colony on Ternate, North Maluku province, Indonesia. These shared intensely blue upperparts and the lack of a feather tuft on the hallux, but two were plain-tailed and two spot-tailed. This contrasted with 24 specimens from North Maluku seen by Rheindt *et al.* (2017: 421), all with spotted tails, leading these authors to conclude that: ‘the new, unpublished findings from Ternate suggest that the morphological division across Stresemann’s Line may not be as clear-cut as previously assumed’.

Here we present the results of collective efforts from different research employing both field observations and genetic studies, with the aim of testing the taxonomic significance of the phenotypic characters that are conventionally used in *Collocalia* identification.



Materials and Methods

Field observations.—Scientific nomenclature *sensu* Rheindt *et al.* (2017) is followed. Locations are given as coordinates, usually taken directly from GPS readings, and elevation as metres above sea level (m). Fig. 2 shows the locations mentioned in the text.

East of the Makassar Strait, in Papua New Guinea, on nine occasions between August 2000 and August 2005, MT, with students from the Pacific Adventist University, handled 275 *C. esculenta nitens* at the abandoned copper mines on Mt. Diamond, Central province (c.09°46.4362''S, 147°32.4446''E; 68 m). Smaller samples were taken at Losave Cave, near the Chimbu / Eastern Highlands province border (06°64.8333''S, 145°15.8889''E; 1,425 m); at a cave 5 km west of Kumul Lodge in Western Highlands province (05°77.9853''S, 143°95.9424''E; 2,614 m), and from one bird caught on the western peak of Mt. Hagen (05°76.4172''S, 144°02.1167''E; 3,670 m) (Table 2). From four nests of *C. esculenta tametamele* in the Japanese tunnels at Sonoma Adventist College, New Britain (c.04°42.7326''S, 152°23.9931''E; 171 m) one adult was caught and measured. At a cave near Lelet village (03°25.1350''S, 151°96.1743''E; 200 m) on New Ireland, 65 *C. esculenta heinrothi* were caught and examined. All of these birds were released after handling. Additionally, in 2016, four birds, identified on geographical grounds as *C. esculenta spilura* (see Coates & Bishop 2000) were caught using a mist-net at a nesting colony below a road bridge over a deep and precipitous river gully on the lower flank of Gunung Gamalama (07°97.182''S, 127°36.8507''E; 204 m) on Ternate, North Maluku province, Indonesia.

Plain-tailed swiftlets were sampled as follows: in 2015, one bird, taken from a small colony of Linchi Swiftlets *C. l. linchi*, at a swiftlet house-farm at Cacaban, Banten Residency, Java, Indonesia (06°10.8828''S, 106°00.1381''E; 61 m); and in 2016, five White-bellied Swiftlets *C. affinis cyanoptila* at a colony in the garage of Buona Vista (Stephen's Place), Fraser's Hill, Pahang, Peninsular Malaysia (03°71.5903''N, 101°75.0444''E; 1,292 m). As outgroup (for complete mitochondrial genome analysis), one Black-nest Swiftlet *Aerodramus maximus* was included from the Perhentian Islands, Terengganu, Peninsular Malaysia (05°96.3306''N, 102°68.3333''E; 3 m).

DNA materials.—Samples for genetic analysis were obtained by plucking one feather from each of the left and right wings in the primary tract; preferentially p3 or p4 (numbered centrifugally). Approximately 0.5 cm at the base of the rachis was cut off with fine scissors and immediately preserved in 70% or 90% ethanol. The birds were then released, apart from five, which were humanely killed by compression of the thorax; breast muscle was excised and immediately preserved in 90% ethanol.

Molecular procedures.—DNA was extracted from preserved material using standard procedures—HiYieldPlus DNA Mini Kit (Real Biotech Corporation) and Wizard Genomic DNA Purification Kit (Promega), following the manufacturers' instructions. Polymerase chain reactions (PCRs) were set up following the primers and conditions in Price *et al.* (2004) for the mitochondrial cytochrome-b (*Cytb*) and NADH dehydrogenase 2 (*ND2*), and Thomassen *et al.* (2005) for the nuclear beta-fibrinogen gene (*Fib*) region, which spanned the partial exon 8, complete intron 7 and partial exon 7 regions. Direct sequencing was performed commercially by FirstBase Laboratory Sdn. Bhd. Samples for next-generation sequencing were prepared using the Nextera DNA Sample Preparation Kit (Illumina, #FC-121-1031), according to the manufacturer's instructions. Next-generation sequencing was performed with a 4nM library on an Illumina MiSeq 600 bp v3 (2×300 bp) following standard procedures.

Data analysis.—We employed both multi-gene phylogenetic and phylogenomic analyses. The former was performed based on the mitochondrial *Cytb* and *ND2* regions,

and the nuclear *Fib7* region; published DNA data from other congeners was incorporated into our analyses. Phylogenomic analysis, based on the mitochondrial genomes, was also performed for a subset of samples.

Phylogenetic analysis for *Cytb*+*ND2* and *Fib* genes.—Twelve DNA sequences of *C. affinis*, *C. esculenta* and *C. linchi* published in previous studies were randomly retrieved from GenBank (Table 1) and added to our phylogenetic analyses based on *Cytb* and *ND2*. Two house-farm white-nest swiftlets, *Aerodramus* sp., and a white-nest swiftlet *A. fuciphagus vestitus* from a Middle Baram cave, Sarawak, Malaysia (Goh *et al.* 2018) were included as outgroups. MtDNA data from the other *Collocalia* taxa deposited by Price *et al.* (2004) were also included (Table 1). Analysis based on *Fib7* employed two outgroup species, i.e., the house-farm swiftlets (161803i, 161703f, 151020f; Goh *et al.* 2018) which were newly sequenced for this study, and *A. maximus* M2–M5 (Thomassen *et al.* 2005). All sequences

TABLE 1
Additional DNA sequences (Price *et al.* 2004 and Thomassen *et al.* 2005) included in the present study.

Taxa	Voucher	Locality	GenBank accession numbers		
			<i>Cytb</i>	<i>ND2</i>	<i>Fib7</i>
<i>A. maximus</i>	DHC03	Sabah	AY294449	AY294511	–
<i>A. maximus</i>	DHC117	Sabah	AY294445	AY294509	–
<i>A. maximus</i>	DHC120	Sabah	AY294446	AY294508	–
<i>A. maximus</i>	DMT040	Sabah	AY294446	AY294509	–
<i>A. maximus</i>	M2	Borneo	–	–	AY513100
<i>A. maximus</i>	M3	Borneo	–	–	AY513098
<i>A. maximus</i>	M4	Borneo	–	–	AY513099
<i>A. maximus</i>	M5	Borneo	–	–	AY513101
<i>C. affinis</i>	DMT059	Selangor	AY294460	AY294522	–
<i>C. affinis</i>	DMT057	Selangor	AY294459	AY294521	–
<i>C. affinis</i>	DMT051	Sandakan	AY294457	AY294519	–
<i>C. affinis</i>	DMT050	Sandakan	AY294458	AY294520	–
<i>C. affinis</i>	DHC88	Lahad Datu	AY294455	AY294517	–
<i>C. affinis</i>	DHC97	Lahad Datu	AY294456	AY294518	–
<i>C. esculenta</i>	FMNH358301	Sibuyan	AY294463	AY294525	–
<i>C. esculenta</i>	FMNH358303	Sibuyan	AY294464	AY294526	–
<i>C. esculenta</i>	ATP92.280	Mindanao	AY294462	AY294524	–
<i>C. esculenta</i>	ATP92.131	Mindanao	AY294461	AY294523	–
<i>C. esculenta</i>	MSP068	New Guinea	AY294466	AY294528	–
<i>C. linchi</i>	DHC72	Bogor	AY294467	AY294529	–

TABLE 2
Morphometric data for *Collocalia esculenta nitens* from Papua New Guinea.

Location where birds were sampled	Date of sampling	Mass			Wing length		
		Mass (g) ± se	Range	<i>n</i>	Wing length (mm) ± se	Range	<i>n</i>
Mt. Diamond	2005–08	6.6 ± 0.02	6.0–8.5	275	102 ± 0.16	91–109	239
Losave Cave	9 June 2000	6.7 ± 0.07	6.0–7.3	22	105 ± 1.05	94–111	15
5 km west of Kumul Lodge	23 July 2005	6.6 ± 0.08	6.4–6.9	7	111.9 ± 1.14	109–118	7
Mt. Hagen (western peak)	18 July 2005	7.6		1	115.5*		1

* Large size attributed to high-elevation habitat (MT)

obtained for this study are deposited in GenBank (accession numbers: MH727218–226). All sequences were aligned using ClustalX2 v.2.1 (Thompson *et al.* 1997) and manually edited and trimmed in BioEdit (Hall 1999).

Maximum Parsimony (MP) analysis was performed using PAUP4.0b10 (Swofford 2002). The strict consensus tree was reconstructed using heuristic search with 100 random-sequence additions, tree bisection reconnection (TBR) branch swapping and 1,000 bootstrap replications. Bootstrap support (BS) values >70% were considered reliable.

The best-fit models (GTR+G for mtDNA and HKY for nuclear DNA) for the Bayesian Inference (BI) were identified using MrModeltest2.2 (Nylander 2004). BI analyses were run in MrBayes3.1 (Huelsenbeck & Ronquist 2001), using two runs of four chains each, and run for 10,000,000 generations with trees sampled every 100 generations. The first 2,500 trees were discarded as burn-in. Posterior probabilities (PP) >0.90 were considered a strong support in this study.

Phylogenomic analysis of mitochondrial genomes.—Next-generation sequence data for phylogenomic analysis was generated using an Illumina MiSeq. A novel mitochondrial genome scaffold was constructed using Integrated Genome Viewer (IGV) v2.3.88 (Robinson *et al.* 2011, Thorvaldsdóttir *et al.* 2013) from the consensus sequences of five *Collocalia affinis cyanoptila* sampled at Fraser's Hill. The hyper-variable D-loop region (517 bp) was excluded from analysis, leaving a mitochondrial sequence length of 15,564 bp. For the four birds sampled on Ternate and five *C. a. cyanoptila* from Fraser's Hill, MiSeq data was quality-assessed and re-sequenced against this scaffold using the on-instrument Illumina MiSeq Reporter Software. Additionally, two genetic outgroups were included: one *C. l. linchi* sampled at Cacaban, Java, and one *Aerodramus maximus* from the Perhentian Islands, Malaysia. The *A. maximus* sample was re-sequenced against a novel mitochondrial scaffold constructed from house-farmed birds of the region. Re-sequenced mitochondrial genomes were manually curated in IGV to produce a consensus sequence for each bird. Sequences obtained for this study are deposited in GenBank [accession number(voucher)]: MT123507(bd108_162710a), MT123508(bd109_162710b), MT123509(bd110_162710c), MT123510(bd111_162710d), MT123511(bd112_162810a), MT921253(bd072_160803a), MT921254(bd073_160803b), MT921255(bd074_160803c), MT921256(bd075_160803d), MT921257(bd006_15200618), MT921258(bd097_162003a). Mitochondrial genome sequences for the 11 birds were aligned using MUSCLE (Edgar 2004). The best-fit model (GTR+G) for Maximum Likelihood phylogeny was selected and performed using MEGA7 (Tamura 2013), with 1,000 Bootstrap replications. Bootstrap values >70% were considered strong support. Estimates of genetic divergence (uncorrected *p*-distances) were computed in MEGA7.

Results

Tail spots.—East of Stresemann's Line (Fig. 2), among some 303 glossy swiftlets, *C. esculenta* subsp. examined, from three cave colonies and one mountain peak in mainland Papua New Guinea, and one cave on New Ireland (Table 2), three birds had no spots on the rectrices. Others had spots on one, two, three or four rectrices between rr2–5 (never on the central pair). Moreover, spots were variable in size, sometimes large, sometimes small (1 mm diameter) and not always equal or present on matching feathers on either side of the tail. One bird from Mt. Diamond had a very small spot on one feather on the right side, but none on any of the left rectrices. Another from the same colony had an extremely small spot on just r3. One bird from the Losave colony also had a very small spot on just one rectrix.

The small sample of four birds on Ternate were all mist-netted in flight and evidently adult. One had lost the right r4, but otherwise the flight feathers were entirely unmoulted, and fresh in appearance. Two conformed to the description in Coates & Bishop (2000) of

C. esculenta spilura, being intensely glossed blue on the upperparts including the dorsal tail-coverts, with white spots on the inner webs of all but the central pair of rectrices. The other two (identical to each other) were similarly intensely blue-glossed above, including the dorsal tail-coverts and tail, but all rectrices were uniform black, glossed blue, with no indication of any white spot on the inner vanes (Figs. 3–4). The hind toes of all four birds lacked a small dorsal tuft.

Green to blue gloss transition.—Repeated sampling of *C. esculenta nitens* at the Mt. Diamond colonies revealed an age-related trend from greenish to blue gloss, as observed for *C. affinis cyanoptila* by Lim (1994). The greenish gloss of a newly moulted bird (Fig. 5) gives way after a few months to a mixture of green and bluish gloss (Fig. 6). Just prior to moult the dorsal plumage exhibits a deep blue surface, with much less gloss, as the feather transmits less light via refraction and reflects more (Fig. 7). Confirmation that these are the stages of change is observed when, at the same nest, a blue adult is perched alongside its young with a green gloss (Fig. 8).

Presence of feather tuft on the hallux.—At three colonies of *C. esculenta* in mainland Papua New Guinea and one on New Ireland, 21% of swiftlets examined had a feather tuft on the hind toe.

Molecular phylogenetic analyses: Cytb + ND2 and Fib7 dataset.—The *Cytb* + *ND2* sequence data were aligned into a data matrix of 1,213 characters, of which 204 characters are parsimony-informative. For the *Fib7* dataset, 32 of 932 characters are parsimony-informative. For each dataset, phylogenetic analyses using BI and MP methods resulted in largely consistent tree topologies, thus only BI topologies are presented here (Figs. 9–10).

In our phylogenetic tree based on the mitochondrial *Cytb* and *ND2* data (Fig. 10), all five individuals of *C. affinis cyanoptila* sampled at Fraser's Hill form a clade (PP 1.00 / BS 100%) with the *Collocalia* individuals collected from Selangor, Sandakan and Lahad Datu (referred to *C. esculenta cyanoptila* by Price *et al.* 2004). *C. marginata* and *C. isonata bagobo* from the Philippines (named *C. esculenta marginata* and *C. e. bagobo* by Price *et al.* 2004) resolve into a cluster with high support (PP 1.00 / BS 95%). The two plain-tailed *C. esculenta* sampled on Ternate form a clade (PP 1.00 / BS 100%) with three other *C. esculenta*, including the two spot-tailed individuals sampled on Ternate by the present study.

Phylogenetic analyses based on the nuclear *Fib7* marker (Fig. 10) again showed high affinity (PP 1.00 / BS 100%) between all four *Collocalia* individuals sampled on Ternate irrespective of tail pattern. They appeared genetically uniform and distant from the *C. affinis cyanoptila* sampled at Fraser's Hill (where only two representatives could be sequenced for the *Fib7* marker).

Mitochondrial genomes.—Phylogenetic analyses based on 'whole' mitochondrial genomes (excluding the hypervariable D-loop region) of a subset of individuals are shown in Fig. 11. Exclusion of the D-loop did not significantly affect genetic divergence or phylogeny results, and resulted in a sequence length of 15,564 bp of mtDNA. The four *Collocalia* individuals sampled on Ternate form a genetically distinct clade with high support (BS 100%), and the five *C. affinis cyanoptila* individuals at Fraser's Hill form another clade (BS 100%), distinct from Ternate birds. These results corroborate the *Cytb* and *ND2* sequence and nuclear *Fib7* marker phylogenies (Figs. 9–10).

Genetic divergence across the mitochondrial genome between the Ternate *C. esculenta spilura* clade and the Fraser's Hill *C. affinis cyanoptila* clade was estimated at 4.68% (Table 3). Both clades are equally genetically distant from the *C. l. linchi* specimen sampled on Java, with 4.74–5.00% divergence. The genetic outgroup for this study, *Aerodramus maximus*, showed a deep genetic divergence of 9.43–9.86% from all *Collocalia* specimens tested.



Figure 3. One of two plain-tailed *Collocalia esculenta spilura*, Mt. Gamalama road bridge, Ternate, Indonesia, August 2016 (Sian E. W. Davies)

Figure 4. One of two spot-tailed *Collocalia esculenta spilura*, Mt. Gamalama road bridge, Ternate, Indonesia, August 2016 (Sian E. W. Davies)

Figure 5. Adult *Collocalia esculenta nitens* displaying large tail spots and the green gloss of fresh plumage, Mt. Diamond, Papua New Guinea, October 2000 (Michael Tarburton)

Figure 6. Another adult *Collocalia esculenta nitens* midway through moult, displaying a mix of blue and green, Mt. Diamond, Papua New Guinea, September 2003 (Michael Tarburton)

Figure 7. Adult *Collocalia esculenta nitens* just prior to moulting, showing its deep blue plumage, Mt. Diamond, Papua New Guinea, August 2001 (Michael Tarburton)

Figure 8. A blue-glossed adult of *Collocalia esculenta nitens* with old plumage (on left) perched alongside its young in fresh green plumage, Mt. Diamond, Papua New Guinea, September 1999 (Michael Tarburton)

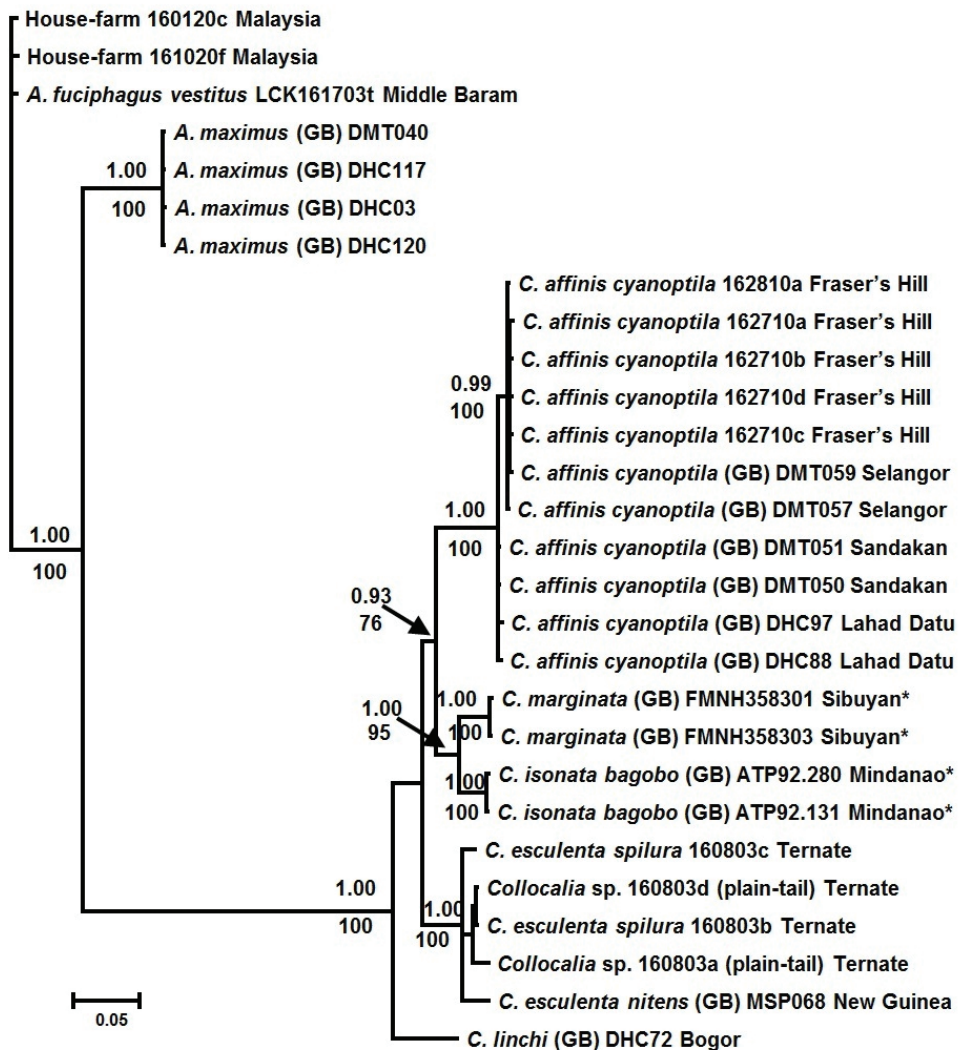

Figure 9. Phylogenetic tree based on the mitochondrial *Cytb* + *ND2* regions (1,213 bp) reconstructed using Bayesian Inference. Numbers above the nodes indicate posterior probabilities >0.90. Bootstrap support values >70% in the maximum parsimony analysis were mapped on the Bayesian topology. Sequences retrieved from GenBank (GB) were published in Price *et al.* (2004). '*' = *Collocalia* taxa from the Philippines not covered in this paper.

As would be expected from near full-length mitochondrial sequences, genetic differences were observed between individuals within both *Collocalia* clades, with divergence of 0.40% within the Ternate group and 0.07% in the Fraser's Hill group. There was high support (BS >70%) for the presence of multiple genetic subclades or maternal lineages within the Ternate group. However, these distinctions did not correlate with the presence or absence of tail spots.

Discussion

Tail spots.—Our observations reveal that, among the population of *C. esculenta spilura* on Ternate, some individuals (50% of the tiny sample of four) were entirely plain-tailed.

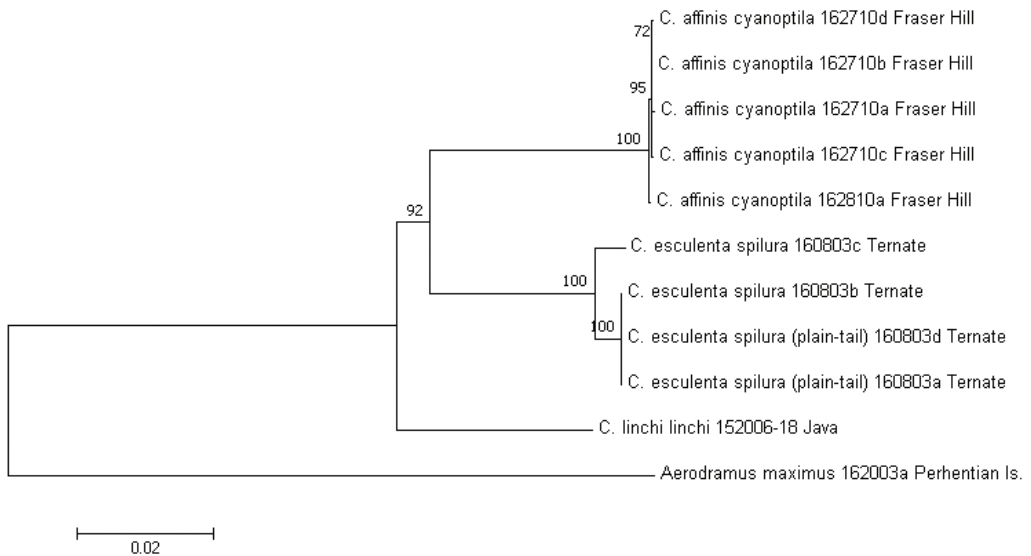

Figure 11. Phylogenetic tree based on novel assembled 'full-length' (with D-loop excluded) mitochondrial genomes (15,564 bp) constructed using Maximum Likelihood with the GTR+G model. Bootstrap support values >70% are indicated above the nodes.

Green and blue gloss.—Between the species (and subspecies) of *C. affinis* and *C. linchi*, variation in the colour of dorsal gloss is supported by genomic evidence (Cibois *et al.* 2018: Fig. 9), and is therefore confirmed as a useful taxonomic indicator. On the other hand, the succession of images of swiftlets at the Mt. Diamond colonies of *C. esculenta nitens* shows age- and wear-related progress from greenish to blue gloss. It is evident that greenish or blue dorsal gloss cannot be considered a character of taxonomic significance among this member of the *C. esculenta* group.

Feather tuft on hallux.—The difficulty of confirming the presence or absence of the single feather tuft on the hallux in *C. affinis cyanoptila*, described by Cranbrook *et al.* (2005), cautions against generalisations as to the prevalence of this character. If this minute feather is shed about mid-term in the slow progression of the moult of the primaries, its absence in an individual should be checked against the moult state of that bird. Variation in New Guinea swiftlets raises doubts that this character is of general taxonomic significance in the *C. esculenta* complex.

Genetic relationships.—Phylogenetic analysis of the mitochondrial markers *Cytb* and *ND2* revealed that the maternal genetic lineages of *Collocalia* may split along geographical lines. This is corroborated by phylogenies produced from the nuclear gene marker *Fib7*. *Cytb* and *ND2* data placed birds sampled at Fraser's Hill within a super-clade of *C. affinis cyanoptila*, comprising two distinct subclades corresponding to Peninsular Malaysia and Bornean Malaysia (Fig. 9).

In both *Cytb* + *ND2* and *Fib7* datasets, the *C. esculenta spilura* sampled on Ternate formed a separate clade. This clade did not cluster with *Collocalia* from the Philippines, which were placed west of Stresemann's Line by Somadikarta (1986), but instead formed a clade with *C. esculenta nitens* from Papua New Guinea (Fig. 9), confirming that plumage variation in Ternate birds does not represent migration from western populations.

This suggestion was corroborated by analysis of mitochondrial genome sequences from a subset of individuals in this study, including the four Ternate *C. e. spilura* and five *C. a.*

cyanoptila from Fraser's Hill, in addition to *C. linchi* and *A. maximus* outgroups (Table 3). This analysis enabled evaluation of genetic divergence across a larger region (15,564 bp vs. *c.*2,000 bp for *ND2 + Cytb* combined), thereby increasing confidence in the calculated divergence values: <0.5% within species, *c.*5% between species, and *c.*10% between genera from the sequenced mitochondrial genomes. These are broadly consistent with values from short (*c.*400 bp) mitochondrial fragments (Rheindt *et al.* 2017).

There was a very close genetic relationship between all four Ternate swiftlets, with a within-group evolutionary distance of 0.400%, comparable to that among Fraser's Hill birds (0.074%). The Ternate group was equally distant from *C. l. linchi* on Java (4.739%) and *C. a. cyanoptila* at Fraser's Hill (4.677%). This distance is equivalent to that between *C. a. cyanoptila* and *C. l. linchi* (5.001%), suggesting a species-level divergence of *c.*5% among *Collocalia*, and that these three species are equally distinct from each other. In addition, all three were equally distant from the *Aerodramus maximus* outgroup, each divergent by *c.*10%. These data imply that tail-spot variation within the Ternate population cannot be attributed to genetic input from another species.

Genetic analyses of mitochondrial and nuclear DNA reveal geographic separation of phylogenies, which do not correlate with the phenotypic characters traditionally used as taxonomic indicators, such as tail spots, green and blue gloss, and hallux feather tuft.

Conclusions

Our observations consolidate the deep divergence at 4.66–8.59% mtDNA, reported by Rheindt *et al.* (2017) between the clades of *Collocalia* spp., separated by the Makassar Strait, and further refine it to *c.*5% (4.677–5.001%) via comparison of long mitochondrial sequences (15,564 bp *cf.* *c.*400 bp in Rheindt *et al.* 2017). Our phylogenetic results support the separation by Rheindt *et al.* (2017) of the *Collocalia esculenta* complex into the 'western *linchi*', 'western white-bellied swiftlet' (*C. affinis*) and 'eastern *C. esculenta*' groups. It is, however, now clear that this phylogenetic separation is not expressed phenotypically, by the presence or absence of white spots on the concealed rectrices. The spot-tailed Christmas Island Swiftlet *C. natalis* is a member of the *C. linchi* group. Two plain-tailed birds on Ternate were genetically inseparable from two spot-tailed *C. esculenta spilura* in the same colony, and relatively distantly related to plain-tailed swiftlets *C. affinis cyanoptila* of Peninsular Malaysia and Borneo. *C. esculenta* in Papua New Guinea displayed great variation in the size, distribution and, rarely, absence (<1% of the sample) of concealed white spots on the rectrices, and 21% of the sample had a small feather tuft on the hallux. These comparisons support Somadikarta's (1986) contention that swiftlets of the *C. esculenta* complex cannot be divided into species by single morphological characters.

A comparatively small sample led Rheindt *et al.* (2017) to conclude that all populations of *C. esculenta* throughout mainland New Guinea have intensely blue-glossed dorsal plumage and clearly marked tail spots, and usually no feather tuft on the hind toe. Based on our observations of phenotypic variation in *C. esculenta* subspecies extending from North Maluku through Papua New Guinea to New Ireland, this conclusion needs to be amended, for the benefit of other students of white-bellied swiftlets and to prevent misleading statements in future regional avifaunas.

Genetic data presented by Cibois *et al.* (2018) from Western Pacific glossy swiftlets showed that the white-rumped taxon *albidior* of New Caledonia, rather than being a subspecies of Satin Swiftlet *C. uropygialis* of Vanuatu, was embedded within *C. esculenta becki* of the Solomon Islands, and *C. e. nitens* of New Guinea. This result suggests that further work may reveal that rump coloration is also not a taxonomically significant indicator among some *C. esculenta* species.

Acknowledgements

Dr S. Somadikarta, doyen of swiftlet studies, has kindly shared his expertise gained over a long lifetime. The approach to this study in the field, and the handling of swiftlets and specimen collection, was assessed by submission to the Ethics Committee of Micropathology Ltd. It was agreed that sampling was to be undertaken humanely, and concluded that there would be no detriment to the bird populations studied. Permission was kindly given by Artem Internusa P.T. and other owners or legal occupiers of all buildings harbouring colonies of swiftlets that we sampled. Collection of genetic material for research was permitted by the Dept. of Wildlife and National Parks, Peninsular Malaysia (JPHL&TN.IP:100-34/1.24 Jld 8 and JPHL&TN. TR:80-1/38 BHG.2(12)). This project was part-funded by the Malaysian Ministry of Education Fundamental Research Grant Scheme (FRGS/2/2014/SG05/UTAR/02/2), and a Universiti Tunku Abdul Rahman (UTAR) Research Scholarship Scheme grant to WSS. Additional travel costs and subsistence were supported in part by the 2014 Merdeka Award to Cranbrook, and *pro bono* by Micropathology Ltd. Max Male is acknowledged for his guidance to caves near Kumul Lodge and Mt. Hagen, and Terrence Habiri's help on trips to Losave Cave and the caves at Mt. Diamond is appreciated. MT also thanks landowners on all three islands in Papua New Guinea for permitting him and his students to visit caves on their land. We thank the four anonymous reviewers and Guy Kirwan for their comments on the manuscript.

References:

- Cibois, A., Thibault, J.-C., McCormack, G. & Pasquet, E. 2018. Phylogenetic relationships of the eastern Polynesian swiftlets (*Aerodramus*, Apodidae) and considerations on other western Pacific swiftlets. *Emu* 118: 247–257.
- Coates, B. J. & Bishop, K. D. 2000. *Panduan lapangan burung-burung di kawasan Wallacea*. BirdLife International Indonesia, Bogor & Dove Publications, Alderley.
- Cranbrook, Earl of, Somadikarta, S., Davison, G. W. H., Lim, C. K. & Möller, H. S. 2005. The Kinabalu Linchi Swiftlet, *Collocalia linchi dodgei* Richmond: an unresolved puzzle. Pp. 133–144 in Mandalam, K. R., Davison, G. W. H. & Regis, P. (eds.) *East Kinabalu Royal Society Expeditions 40th Anniversary monograph*. Kota Kinabalu, Sabah Society.
- Edgar, R. C. 2004. MUSCLE: multiple sequence alignment with high accuracy and high throughput. *Nucleic Acids Res.* 32: 1792–1797.
- Goh, W. L., Siew, W. S., Davies, S. E. W., Ball, S., Khoo, G., Lim, C. K., Rahman, M. A. & Cranbrook, Earl of. 2018. Genetic diversity among white-nest swiftlets genus *Aerodramus* (Aves: Apodidae: Collocaliini) of house-farms in Malaysia and Indonesia. *Raffles Zool. Bull.* 66: 350–360.
- Hall, T. A. 1999. BioEdit: a user-friendly biological sequence alignment editor and analysis program for Windows 95/98/NT. *Nucleic Acids Symp. Ser.* 41: 95–98.
- Huelsensbeck, J. P. & Ronquist, F. 2001. MRBAYES: Bayesian inference of phylogenetic trees. *Bioinformatics* 17: 754–755.
- Lim, C. K. 1994. Variasi protein dan systematik Burung layang-layang perut putih (white-bellied swiftlets) dari tiga koloni di Semenanjung Malaysia. B.Sc. dissertation. Zool. Dept., Univ. Malaya, Kuala Lumpur.
- Mayr, E. 1931. Birds collected during the Whitney South Sea Expedition XIII. *Amer. Mus. Novit.* 486: 1–29.
- Mayr, E. & Camras, S. 1938. Birds of the Crane Pacific Expedition. *Publ. Field Mus. Nat. Hist. Zool. Ser.* 20: 453–473.
- Moyle, R. G., Hosner, P. A., Nais, J., Lakim, M. & Sheldon, F. H. 2008. Taxonomic status of the Kinabalu 'linchi' swiftlet. *Bull. Brit. Orn. Cl.* 128: 94–100.
- Nylander, J. A. A. 2004. MrModeltest v.2. Evolutionary Biology Centre, Uppsala Univ.
- Price, J. J., Johnson, K. P. & Clayton, D. H. 2004. The evolution of echolocation in swiftlets. *J. Avian Biol.* 35: 135–143.
- Rheindt, F. E., Christidis, L., Norman, J. A., Eaton, J. A., Sadanandan, K. R. & Schodde, R. 2017. Speciation in Indo-Pacific swiftlets (Aves: Apodidae): integrating molecular and phenotypic data for a new provisional taxonomy of the *Collocalia esculenta* complex. *Zootaxa* 4250: 401–433.
- Robinson, J. T., Thorvaldsdóttir, H., Winckler, W., Guttman, M., Lander, E. S., Getz, G. & Mesirov, J. P. 2011. Integrative Genomics Viewer. *Nature Biotech.* 29: 24–26.
- Salomonsen, F. 1983. Revision of the Melanesian swiftlets (Apodes, Aves) and their conspecific forms in the Indo-Australian and Polynesian region. *Kong. Dansk. Vidensk. Selsk. Biol. Skr.* 23: 1–112.
- Somadikarta, S. 1982. The White-bellied Swiftlet *Collocalia esculenta* from Java. *Bull. Brit. Orn. Cl.* 102: 18–20.
- Somadikarta, S. 1986. *Collocalia linchi* Horsfield and Moore - a revision. *Bull. Brit. Orn. Cl.* 106: 32–40.
- Stresemann, E. 1940. Die Vögel von Celebes. Teil III. Systematik und Biologie. *J. Orn.* 88: 389–487.
- Swofford, D. L. 2002. PAUP*. *Phylogenetic analysis using parsimony (*and other methods)*. Version 4. Sinauer Associates, Sunderland, MA.
- Tamura, K., Stecher, G., Peterson, D., Filipski, A. & Kumar, S. 2013. MEGA6: molecular evolutionary genetics analysis version 6.0. *Mol. Biol. Evol.* 30: 2725–2729.
- Thomassen, H. A., Tex, R. J., de Bakker, M. A. G. & Povel, G. D. E. 2005. Phylogenetic relationships amongst swifts and swiftlets: a multi locus approach. *Mol. Phylo. & Evol.* 37: 264–277.

- Thompson, J. D., Gibson, T. J., Plewnial, F., Jeanmougin, F. & Higgins, D. G. 1997. The Clustal X windows interface: flexible strategies for multiple sequence alignment aided by quality analysis tools. *Nucleic Acids Res.* 25: 4876–4882.
- Thorvaldsdóttir, H., Robinson, J. T. & Mesirov, J. P. 2013. Integrative Genomics Viewer (IGV): high-performance genomics data visualization and exploration. *Briefings in Bioinformatics* 14: 178–192.
- Wallace, A. R. 1864. On the identification of the *Hirundo esculenta* of Linnaeus, with a synopsis of the described species of *Collocalia*. *Proc. Zool. Soc. Lond.* 1863: 382–385.

Addresses: Sian E. W. Davies, Micropathology Ltd., Univ. of Warwick Science Park, Coventry, CV4 7EZ, UK, e-mail: s.davies@micropathology.com. Wei Lim Goh, Dept. of Biological Science, Faculty of Science, Universiti Tunku Abdul Rahman (UTAR), Jalan Universiti, Bandar Barat, 31900 Kampar, Perak, Malaysia, e-mail: wlgo@utar.edu.my. Sarah P. Ball, Micropathology Ltd., Univ. of Warwick Science Park, Coventry, CV4 7EZ, UK, e-mail: s.ball@micropathology.com. Earl of Cranbrook, Old Barn, Church Farm, Great Glemham, Saxmundham, Suffolk IP17 2DB, UK, e-mail: lordcranbrook@greatglemhamfarms.co.uk. Wei Sheng Siew, D6.10, Block D, Level 6, Research Laboratory 2, Taylor's University Lakeside Campus, No. 1, Jalan Taylor's, 47500 Subang Jaya, Selangor, Malaysia, e-mail: vin.siew@gmail.com. Michael Tarburton, School of Science & Technology, Pacific Adventist University, PMB Boroko, Papua New Guinea, e-mail: tarburton.m@optusnet.com.au

