

**THE C120 MAGNUM WITH PAN TRIGGER: A HUMANE TRAP FOR MINK  
(MUSTELA VISON)**

Authors: Gilbert Proulx, Morley W. Barrett, and Stephen R. Cook

Source: Journal of Wildlife Diseases, 26(4) : 511-517

Published By: Wildlife Disease Association

URL: <https://doi.org/10.7589/0090-3558-26.4.511>

---

BioOne Complete ([complete.BioOne.org](http://complete.BioOne.org)) is a full-text database of 200 subscribed and open-access titles in the biological, ecological, and environmental sciences published by nonprofit societies, associations, museums, institutions, and presses.

Your use of this PDF, the BioOne Complete website, and all posted and associated content indicates your acceptance of BioOne's Terms of Use, available at [www.bioone.org/terms-of-use](http://www.bioone.org/terms-of-use).

Usage of BioOne Complete content is strictly limited to personal, educational, and non-commercial use. Commercial inquiries or rights and permissions requests should be directed to the individual publisher as copyright holder.

---

BioOne sees sustainable scholarly publishing as an inherently collaborative enterprise connecting authors, nonprofit publishers, academic institutions, research libraries, and research funders in the common goal of maximizing access to critical research.

## THE C120 MAGNUM WITH PAN TRIGGER: A HUMANE TRAP FOR MINK (*MUSTELA VISON*)

Gilbert Proulx,<sup>1,2</sup> Morley W. Barrett,<sup>1</sup> and Stephen R. Cook<sup>1,3</sup>

<sup>1</sup> Humane Trapping Program, Alberta Environmental Centre, Bag 4000, Vegreville, Alberta, Canada T0B 4L0

<sup>2</sup> Present address: Forestry Department, Alberta Research Council, P.O. Box 8330, Postal Station F, Edmonton, Alberta, Canada T6H 5X2

<sup>3</sup> Present address: Fiberglass Canada, P.O. Box 595, Edmonton, Alberta, Canada T5J 2L1

**ABSTRACT:** The C120 Magnum trap, equipped with a 66 × 69 mm pan trigger, which favored double strikes in the neck and thorax regions, successfully killed nine of nine wild mink (*Mustela vison*) in simulated natural conditions. Average times to loss of consciousness and heartbeat were estimated at <72 (±24) sec and 158 (±48) sec, respectively, after firing of the trap. This study confirmed that the C120 Magnum trap can be expected to render >79% of all captured mink unconscious in ≤3 min ( $P < 0.05$ ). This is the first mink kill trap to meet the requisites of the Canadian General Standards Board regarding killing traps.

**Key words:** C120 Magnum quick-kill trap, humane trapping, mink, *Mustela vison*, rotating-jaw trap, experimental study.

### INTRODUCTION

Because of the perceived cruelty associated with use of the leghold trap, the wildlife management authorities of three Canadian provinces have recently prohibited the use of conventional leghold traps in land sets for capturing most furbearers (Barrett et al., 1988). In most regions, the commercially available rotating-jaw Conibear® (Woodstream Corporation, Lititz, Pennsylvania 17543, USA) has been promoted as an alternative means for trapping small furbearers. The Conibear 120® (C120) is marketed as a quick-kill trap for mink (*Mustela vison*) and its use is recommended in trapping and conservation manuals (Canadian Trappers Federation, 1984; Alberta Vocational Centre, 1987). However, the standard C120, equipped with a two-prong trigger, does not consistently strike mink in vital areas (Cook et al., 1973; Voigt, 1974) and its impact and clamping energies are lower than those recommended by the Canadian General Standards Board (1984) for marten (*Martes americana*) and mink (Cook and Proulx, 1989).

Proulx et al. (1989a) developed the C120 Magnum trap (the researchers did not ac-

quire a registered trademark so that the trap can be produced by any manufacturer) which rated higher than the Canadian General Standards Board's (1984) kill threshold values (minimum striking and clamping forces) for marten and mink. This trap quickly killed marten struck in the head-neck region (Proulx et al., 1989a), but did not effectively kill mink struck in the neck (Proulx and Barrett 1989). This may be due to the greater cervical musculature and stronger bones of the mink. However, the work with marten (Proulx et al., 1989a) demonstrated that double strikes, where animals were simultaneously struck in the head-neck and thorax regions by the distal and proximal rotating-jaws, respectively, produced consistent and rapid unconsciousness. Double strikes damaged the central nervous system or impeded the respiratory functions of the animals (Proulx et al., 1989a). Given similar strike locations, the C120 Magnum trap could have the potential to quickly kill mink.

The objectives of this study were (1) to develop a trigger system for the C120 Magnum trap that will ensure consistent double strikes in the head-neck and thorax regions of mink, under simulated natural

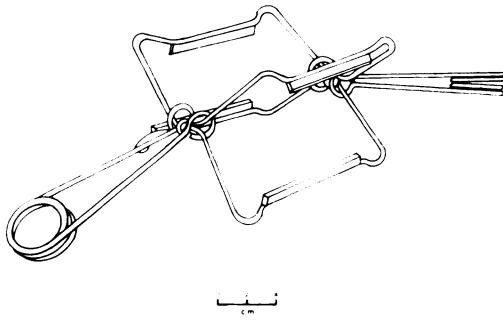

FIGURE 1. Diagram of the Conibear 120 Magnum trap with four clamping bars.

conditions; and (2) to evaluate the potential of the C120 Magnum to quickly kill mink which received a double strike.

#### MATERIAL AND METHODS

The study was conducted in a 2.2 ha forested compound at the Alberta Environmental Centre (Vegreville, Alberta, Canada T0B 4L0). Wild-

caught mink were individually introduced in  $12.2 \times 5.2 \times 4.4$  m test enclosures and were allowed a minimum of 3 days to acclimate to simulated natural conditions before any tests were conducted. Enclosures were kept under surveillance with two remote control Panasonic® WV 1854 video-cameras (Avicom Industrial Communications, Edmonton, Alberta, Canada T5S 1G7) equipped with a Comiscar® 15–180 mm F1.9 lens (Avicom Industrial Communications, Edmonton, Alberta, Canada, T5S 1G7) and a high efficiency 500 watt infrared (invisible to animal eyes) light illuminator (Avicom Industrial Communications). Personnel observed the video monitors in a laboratory building approximately 125 m from the enclosures. Proulx et al. (1989b) described the facilities, equipment and husbandry procedures.

The C120 Magnum traps used in this study were similar to those of Proulx et al. (1989a). However, they had four clamping bars instead of two to reinforce the trap's metal frames (Fig. 1). Traps were set in a ground cubby box (Fig. 2) (Proulx et al., 1989b) similar to the one used by trappers (Alberta Vocational Centre, 1987).

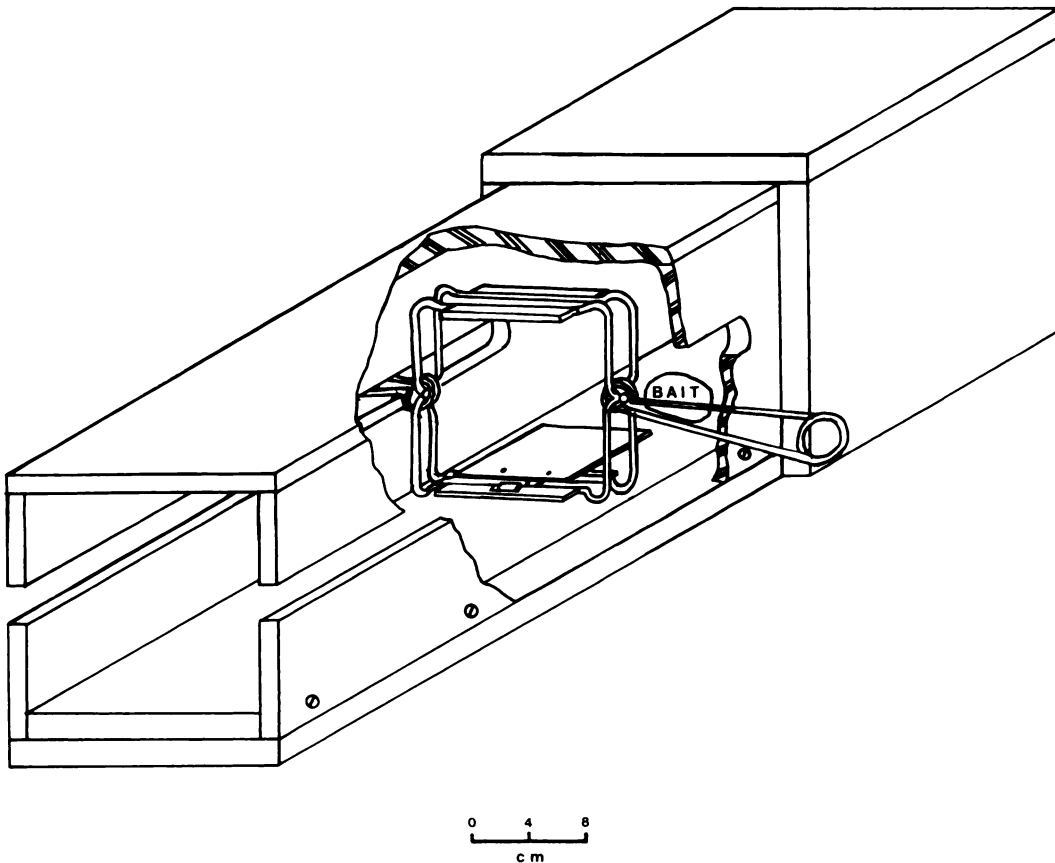

FIGURE 2. C120 Magnum with 66 × 69 mm pan trigger in cubby set.

They were equipped with pan triggers which operated on a cam-lever principle (Fig. 3). A bait consisting of ranch mink feed was tied down 10 cm behind the center of the trap.

A test sequence was designed to minimize pain and suffering of animals, to ensure efficient use of mink, and to thoroughly evaluate the killing potential of traps. It consisted of approach tests, pre-selection tests, kill tests, and performance confirmation tests (Proulx et al., 1989a, b). In order to qualify for each category of testing, traps had to pass the previous category.

In approach tests, naive animals that presumably had never encountered a Conibear trap<sup>®</sup> were allowed to approach C120 Magnum traps wired in the set position so that the traps could be triggered but not close completely and injure the animals. The strike locations were determined on video monitors by projecting the arc movement of the striking bars on the animals at firing time. These tests were used to develop a trigger system that would ensure that mink would be consistently struck in both head-neck and thorax regions. A trigger system was judged acceptable if animals were successfully positioned in five or more of six approaches. Two series of six approaches were conducted with a 65 × 100 mm and a 81 × 91 mm pan triggers. However, during the approach tests, it was noticed that mink could accidentally fire the trap before entering it, by stepping on the anterior part of the part of the pan which faced the cubby entrance. The pan was subsequently shortened to a 69 mm length so that it did not extend past the proximal striking jaw (Fig. 2).

In the past, a trap was judged "humane" when it rendered three of three animals irreversibly unconscious within 3 min (Federal Provincial Committee for Humane Trapping, 1981). However, Proulx et al. (1989a, b) considered that a sample size of three was unacceptably low to reach a satisfactory conclusion about the true effectiveness of a trap. They suggested that the assessment of the killing ability of a trap should involve more kill tests and that a trap should be considered "humane" if it has the potential to kill >79% of all target animals in an actual field situation. Such a performance level is considered to be very high and no commercial trapping device has been shown to meet it (Proulx and Barrett, 1989).

This study followed previous kill test protocols (Proulx et al., 1989a, b). The killing potential of the C120 Magnum trap was first assessed in pre-selection tests with six traps and six mink (those used in the approach tests with the 65 × 100 mm pan trigger) immobilized with ketamine hydrochloride (10–20 mg/kg; Austin Laboratories, Joliette, Quebec, Canada J6E 3Z1).

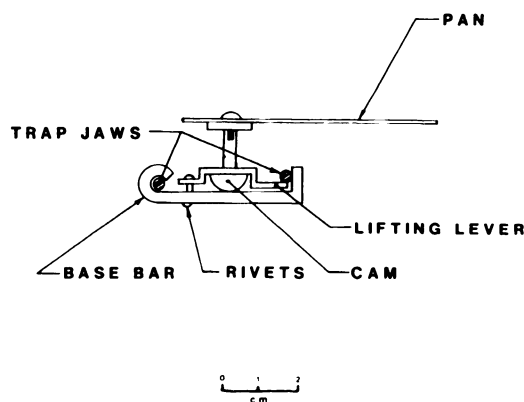

FIGURE 3. Diagram of the 66 × 69 mm pan trigger of the Conibear 120 Magnum trap.

This preliminary assessment allowed the researchers to determine if the C120 Magnum generated sufficient impact and clamping energies to quickly kill mink, without causing suffering to the animals. If a trapping device would not effectively kill immobilized animals, it is unlikely that it would do so with active animals that are aware of what is happening to them and would "fight" the trap (Proulx et al., 1989b). The C120 Magnum would pass the pre-selection tests if it rendered at least five of six animals irreversibly unconscious in ≤3 min (Canadian General Standards Board, 1984). Irreversible unconsciousness was diagnosed by loss of corneal and palpebral reflexes (Walker, 1979; Horton, 1980; Rowsell et al., 1981) with inevitable subsidence into death (loss of cardiac activity determined with a stethoscope). The immobilized animals were situated in traps in a position that duplicated placement in the approach tests (Proulx et al., 1989b), and the presence of their eye reflexes was confirmed before firing the trap.

Upon success at the pre-selection test level, a second assessment of the potential effectiveness of the C120 Magnum was carried out in six kill tests with each trap equipped with a 66 × 69 mm pan trigger and placed in a cubby set. The C120 Magnum would be considered potentially effective if it successfully rendered at least five of six animals irreversibly unconscious in ≤3 min.

Thereafter, the C120 Magnum was evaluated in additional kill tests, termed performance confirmation tests, in order to be 95% confident that it could be expected to effectively kill >79% of all captured mink (Proulx et al., 1989a). On the basis of the normal approximation to the binomial distribution (Fleiss, 1981), the C120 Magnum would be expected to effectively kill >79% of mink on traplines if, during the kill and performance confirmation tests, it rendered nine of

TABLE 1. Location of strikes, time intervals between trap firing and irreversible loss of corneal/palpebral reflexes and heartbeat, and major trauma of mink in preselection tests with the C120 Magnum trap.

Mink number	Weight (kg)	Sex	Location of double strikes	Loss after firing (sec)		Major trauma
				Corneal/palpebral reflexes	Heartbeat	
87-975	1.0	F	C <sub>7</sub> <sup>a</sup> and T <sub>12</sub> <sup>b</sup>	137	324	Severe Compression and laceration of muscles at impact sites.
87-998	1.4	M	Top of skull and T <sub>1</sub>	5	180	Dorsal compression of temporal muscle. Severe meningeal hemorrhage. Dorso-ventral compression of muscle at T <sub>1</sub> . Lungs severely congested and edematous.
87-991	0.8	F	Top of skull and T <sub>1</sub>	5	152	Transverse fissure (1 cm) of frontal bone at impact site and discrete hemorrhage (2 cm diameter) on dorsal surface of frontal brain. Severe compression and laceration of muscles at T <sub>1</sub> and small fracture of spinal process. Lungs congested and edematous.
87-992	1.7	F	Top of skull and T <sub>1</sub>	140	187	Dorso-ventral compression of the skull with bone deformation but no fracture. Lungs congested and possibly edematous.
87-1011	1.5	M	C <sub>1</sub> and T <sub>1</sub>	26	226	Mild compression of muscles at impact sites. Lungs congested and slightly edematous.
87-995	1.1	U	Muzzle and C <sub>5, 6</sub>	48	279	Compression and laceration of muscles at C <sub>5</sub> and C <sub>6</sub> . Lungs markedly congested and slightly edematous.

<sup>a</sup> cervical vertebrae

<sup>b</sup> thoracic vertebrae

M: male, F: female, U: unknown

nine (0 failure), or 13 of 14 (one failure), or 18 of 20 (two failures) mink irreversibly unconscious in  $\leq 3$  min (Proulx et al., 1989a).

The kill tests were conducted from October 1987 to February 1988. Upon firing of the trap, researchers ran to the test enclosure to monitor the state of consciousness of the animals. Animals were necropsied by a veterinary pathologist at the Alberta Environmental Centre (Vegreville, Alberta, Canada T0B 4L0). The pelts were examined for damage before and after skinning the animals.

Animal husbandry and research procedures were conducted in accordance with the guidelines of the Canadian Council on Animal Care (1984). Protocols for the kill tests were referred to the Council for their review prior to implementation.

## RESULTS

All approach tests resulted in double strikes in the head-neck and thorax regions.

In pre-selection tests, average times to loss of consciousness and heartbeat were 60 ( $\pm 63$ ) sec and 225 ( $\pm 66$ ) sec, respectively (Table 1). Damage to the central nervous system was apparent in two cases. Compression and/or laceration of muscles and congestion of lungs were common in all kills (Table 1). The trap successfully passed (six of six) the pre-selection tests.

All the kill and performance confirmation tests were successful (Table 2). In the majority (78%) of cases, corneal/palpebral reflexes had been lost prior to arrival of the observers and average time to loss of consciousness was  $< 72$  ( $\pm 24$ ) seconds (Table 2). Heartbeat was lost, on average, 158 ( $\pm 48$ ) seconds after firing of the trap. The central nervous system was not damaged. Fractures were recorded in four animals

TABLE 2. Location of strikes, time between trap firing and irreversible loss of corneal/palpebral reflexes and heartbeat, and major trauma of mink in kill/performance confirmation tests with the C120 Magnum trap with a 66 × 69 mm pan trigger.

Mink number	Weight (kg)	Sex	Location of double strikes	Loss after firing (sec)		Major trauma
				Corneal/palpebral reflexes	Heartbeat	
87-947	1.5	M	C <sub>1</sub> <sup>a</sup> and T <sub>n</sub> <sup>b</sup>	≤67 <sup>c</sup>	— <sup>d</sup>	Severe congestion and hemorrhage involving 60% of the lungs; foamy fluids in bronchi and trachae.
86-1001	0.9	U	C <sub>4</sub> and T <sub>11</sub>	≤64 <sup>c</sup>	164	Severe compression and laceration of muscles at impact sites; compressive fracture on spinal process at C <sub>4</sub> and T <sub>11</sub> . Red patchy discoloration involving 40% of the lungs.
87-1002	1.4	U	C <sub>1</sub> and T <sub>4</sub>	102	142	Severe compression of muscles at impact sites. Red patchy discoloration involving 50% of lungs.
87-949	1.5	U	C <sub>4</sub> , <sub>5</sub> and T <sub>10</sub>	≤55 <sup>c</sup>	138	Severe compression and laceration of muscles at impact sites; compressive fracture on spinal process at C <sub>4</sub> . Hemorrhagic pericardium due to blow and subsequent cardiac rupture at base of left atrium.
87-948	0.9	F	T <sub>2</sub> and L <sub>1</sub>	117	230	Compression and laceration of muscles at impact sites.
87-971	1.7	F	C <sub>7</sub> - T <sub>1</sub> and T <sub>13</sub>	≤60 <sup>c</sup>	115	Compression of muscles at impact sites; compressive fracture of spinal process at T <sub>1</sub> and T <sub>2</sub> .
87-951	0.8	F	C <sub>7</sub> and T <sub>13</sub>	≤47 <sup>c</sup>	205	Compression and laceration of muscles at impact sites; compressive fracture of spinal process at C <sub>7</sub> .
87-965	1.3	M	Atlanto-Occipital Joint and T <sub>4</sub>	≤87 <sup>c</sup>	187	Compression of muscles at impact sites. Possible dislocation of atlanto-occipital joint.
87-962	0.8	F	C <sub>3</sub> and T <sub>10</sub>	≤50 <sup>c</sup>	86	Compression and laceration of muscles at impact sites. Massive hemopericardium and hemothorax with laceration of heart (0.5 cm from apex).

<sup>a</sup> cervical vertebrae

<sup>b</sup> thoracic vertebrae

<sup>c</sup> animal was unconscious upon arrival of the observer

<sup>d</sup> difficulty in assessing the exact time

M: male, F: female, U: unknown

and were mainly limited to vertebral spinal processes. Major trauma consisting of cardiac tamponade, hemothorax and pulmonary hemorrhage were found in a few mink (Table 2).

This study confirmed that the C120 Magnum equipped with a 66 × 69 mm can be expected to render >79% of captured mink unconscious in ≤3 min ( $P < 0.05$ ).

## DISCUSSION

The C120 Magnum with pan trigger is the first mink kill trap to meet the requisites of the Canadian General Standards Board (1984). Because of its longer springs, the C120 Magnum is easier to set than the C120<sup>®</sup>. It is a safe trap to work with when the springs are equipped with safety hooks identical to those of the Conibear 220<sup>®</sup> trap

(Woodstream Corporation) and when a Conibear Safety Gripper® (Woodstream Corporation) is used to hold the jaws together while setting the trap. Although the C120 Magnum is more powerful than the C120® (Proulx et al., 1989a), it did not damage mink pelts. The efficacy of this trap under controlled conditions now warrants field studies to compare its capture efficiency to that of commercial devices.

This study, and the work of Proulx et al. (1989a, b), illustrates that it is possible to increase the killing potential of traps. However, it also points out that caution should be exercised in expressing general statements about types of strikes. In the past, double strikes were not acceptable mainly because such strikes had never been critically evaluated. Some of the preliminary work on double strikes involved only a few animals and inconsistent strike locations (Novak, 1981) or trap designs which were much less powerful than the C120 Magnum (Gilbert, 1981). Research using animals in simulated natural environments is necessary to confirm the killing potential of trap whose energies meet or exceed the kill thresholds recommended by the Canadian General Standards Board (1984). These animal studies lead to the establishment of relationships between strike location and time to unconsciousness, and the accumulation of background data necessary to interpret the killing performances of traps on working traplines.

#### ACKNOWLEDGMENTS

We thank C. Dulberg and A. W. Hawley for statistical advice; B. Dew, D. Hobson, D. Nelson and J. Nolan for technical help; A. Lopez for postmortem examinations; and E. Rudik and M. Schultz for machine shop work.

#### LITERATURE CITED

- ALBERTA VOCATIONAL CENTRE. 1987. Trapping and conservation manual, 5th ed. Alberta Advanced Education and Alberta Forest, Lands and Wildlife, Lac La Biche, Alberta, Canada, 524 pp.
- BARRETT, M. W., G. PROULX, AND N. JOTHAM. 1988. Wild fur industry under challenge—The Canadian response. North American Wildlife and Natural Resources Conference 53: 180–190.
- CANADIAN COUNCIL ON ANIMAL CARE. 1984. Guide to the care and use of experimental animals, Vol. 2. Ottawa, Ontario, Canada, 208 pp.
- CANADIAN GENERAL STANDARDS BOARD. 1984. Animal traps, humane mechanically-powered, trigger activated. Report CAN 2-144.1-M84, Ottawa, Ontario, Canada, 9 pp.
- CANADIAN TRAPPERS FEDERATION. 1984. Canadian trappers manual. North Bay, Ontario, Canada, 231 pp.
- COOK, L., M. NOVAK, AND L. WALKER. 1973. Effectiveness of some furbearer animal traps. Ontario Ministry of Natural Resources, Toronto, Ontario, Canada, 39 pp.
- COOK, S. R., AND G. PROULX. 1989. Mechanical evaluation and optimization of the rotating-jaw Conibear 120 trap. *ASTM Journal of Testing and Evaluation* 17: 190–195.
- FEDERAL PROVINCIAL COMMITTEE FOR HUMANE TRAPPING. 1981. Final report Committee of the Federal Provincial Wildlife Conference, Canadian Wildlife Service, Ottawa, Ontario, Canada, 172 pp.
- FLEISS, J. L. 1981. Statistical methods for rates and proportions, 2nd ed. John Wiley and Sons, New York, New York, 321 pp.
- GILBERT, F. F. 1981. Maximizing the humane potential of traps—The Vital and the Conibear 120. *In Proceedings of the Worldwide Furbearer Conference*, J. A. Chapman and D. Pursley (eds.). Worldwide Furbearer Conference Inc., University of Maryland, Frostburg, Maryland, pp. 1630–1646.
- HORTON, J. M. 1980. Use of anaesthesia, care of the unconscious. *British Medical Journal* 281: 38–40.
- NOVAK, M. 1981. Capture tests with underwater snares, leg-hold, Conibear and Mohawk traps. *Canadian Trapper* 9: 18–23.
- PROULX, G., AND M. W. BARRETT. 1989. On the development and implications of the Conibear 120 Magnum trap to harvest marten and mink. *In Proceedings Northeast Fur Resources Technical Committee*, R. Lafond (ed.). Beauport, Quebec, Canada, pp. 194–209.
- , ———, AND S. R. COOK. 1989a. The C120 Magnum trap: An effective quick-kill trap for marten. *Wildlife Society Bulletin* 17: 294–298.
- , S. R. COOK, AND M. W. BARRETT. 1989b. Assessment and preliminary development of the rotating-jaw Conibear 120 trap to effectively kill marten (*Martes americana*). *Canadian Journal of Zoology* 67: 1074–1079.
- ROWSSELL, H. C., J. RITCEY, AND F. COX. 1981. Assessment of effectiveness of trapping methods in the production of a humane death. *In Proceedings of the Worldwide Furbearer Conference*, J. A. Chapman and D. Pursley (eds.). Worldwide

- Furbearer Conference Inc., University of Maryland, Frostburg, Maryland, pp. 1630-1646.
- VOIGT, D. 1974. Trap testing and development. *American Trapper* 3: 14-17.
- WALKER, A. E. 1979. Advances in the determination of cerebral death. *Advances in Neurology* 22: 167-172.

*Received for publication 26 May 1989.*