



## **Intra- and Interspecific Genetic Complexities of Two *Eothenomys* Species in Honshu, Japan**

Authors: Iwasa, Masahiro A., and Suzuki, Hitoshi

Source: Zoological Science, 20(10) : 1305-1313

Published By: Zoological Society of Japan

URL: <https://doi.org/10.2108/zsj.20.1305>

---

BioOne Complete ([complete.BioOne.org](https://complete.BioOne.org)) is a full-text database of 200 subscribed and open-access titles in the biological, ecological, and environmental sciences published by nonprofit societies, associations, museums, institutions, and presses.

Your use of this PDF, the BioOne Complete website, and all posted and associated content indicates your acceptance of BioOne's Terms of Use, available at [www.bioone.org/terms-of-use](https://www.bioone.org/terms-of-use).

Usage of BioOne Complete content is strictly limited to personal, educational, and non - commercial use. Commercial inquiries or rights and permissions requests should be directed to the individual publisher as copyright holder.

---

BioOne sees sustainable scholarly publishing as an inherently collaborative enterprise connecting authors, nonprofit publishers, academic institutions, research libraries, and research funders in the common goal of maximizing access to critical research.

# Intra- and Interspecific Genetic Complexities of Two *Eothenomys* Species in Honshu, Japan

Masahiro A. Iwasa<sup>†</sup> and Hitoshi Suzuki<sup>\*</sup>

Laboratory of Ecology and Genetics, Graduate School of Environmental Earth Science,  
Hokkaido University, Sapporo, Hokkaido 060-0810, Japan

**ABSTRACT**—Differences in the nuclear ribosomal DNA (rDNA), mitochondrial DNA (mtDNA), cytochrome *b* (*Cytb*), and Y chromosomal *Sry* genes were used to assess intra- and interspecific relationships in two Japanese red-backed voles, *Eothenomys andersoni* and *E. smithii*, focusing on areas where the two species might come into contact. In the Kii Peninsula, southwestern Honshu, which contains an allopatric population of *E. andersoni* isolated from its main range, the rDNA-RFLP data provide robust evidence of past mutual interspecific gene introgression, while the *Cytb* and *Sry* sequences were specific to this population. In central Honshu, where *E. andersoni* and *E. smithii* inhabit higher and lower altitudes, respectively, with a narrow sympatric zone, the rDNA-RFLP and *Sry* variation was specific for each species, while introgression of the mtDNA from *E. smithii* to *E. andersoni* was seen. These complex patterns in the gene markers are consistent with our previous notions derived from sex chromosome variation. Our previous and present data strongly suggest that the evolution of these vole species, which are morphologically and cytogenetically distinct, involves complex genetic interactions and the resultant combinations of genes are sometimes peculiar, mainly due to the *Cytb* haplotypes. However, phylogenetic analysis using a combination of maternal, paternal, and biparental markers has proven useful for understanding the evolutionary history given the complex phylogenetic background.

**Key words:** *Eothenomys*, Honshu, ribosomal DNA gene, cytochrome *b*, *Sry*

## INTRODUCTION

The Japanese Islands, which cover a large distance from north to south and have many alpine areas, harbor many subjects for biogeographical studies. Small mammals in Japan, especially those from Honshu, Shikoku, and Kyushu, tend to have sibling species or local populations where speciation is going on to various extents. Morphological, cytogenetic, and molecular genetic studies of red-backed voles, which are typical small mammals, have revealed unexpected patterns of evolution that are complex and conflicting (e.g., Iwasa, 1998; Suzuki *et al.*, 1999; Iwasa *et al.*, 1999; Iwasa and Suzuki, 2002a).

The Japanese *Eothenomys* voles (Rodentia, Arvicolinae) *E. andersoni* and *E. smithii* inhabit all the Japanese islands except Hokkaido (Abe *et al.*, 1994). *Eothenomys andersoni* is distributed in the eastern half of Honshu, with

an allopatric relic population in the Kii Peninsula of Honshu (Iwasa and Suzuki, 2002a; Fig. 1). *E. smithii* is distributed in Kyushu, Shikoku, and Honshu except for the northern part (Abe *et al.*, 1994; Fig. 1), and is horizontally parapatric with *E. andersoni* in the Kii Peninsula and vertically parapatric in central Honshu. Both species include several local populations that have been characterized morphologically (Imaizumi, 1979). Researchers have examined the genetic features of these species using karyotypes, nuclear rDNA-RFLP, and the sequences of mitochondrial and nuclear genes (Tsuchiya, 1981; Kitahara and Harada, 1996; Iwasa *et al.*, 1999; Suzuki *et al.*, 1999; Iwasa and Tsuchiya, 2000; Iwasa and Suzuki, 2002a, b). However, the genetic patterns seen within and between species are very complex and the intra- and interspecific relationships are poorly understood, especially in the areas where two species are in contact historically and contemporarily, as in the Kii Peninsula and central Honshu.

Suzuki *et al.* (1999) showed that *E. andersoni* and *E. smithii* differ in four restriction sites along the spacer regions of the 18S and 28S genes (rDNA) based on a restriction fragment length polymorphism (RFLP) analysis, but the Kii Peninsula population of *E. andersoni* in Honshu (Fig. 1) car-

\* Corresponding author: Tel: +81-11-706-2279;

FAX: +81-11-706-2279.

E-mail: htsuzuki@ees.hokudai.ac.jp

<sup>†</sup> Present address: Laboratory of Public Health, Graduate School of Veterinary Medicine, Hokkaido University, Sapporo, Hokkaido 060-0818, Japan

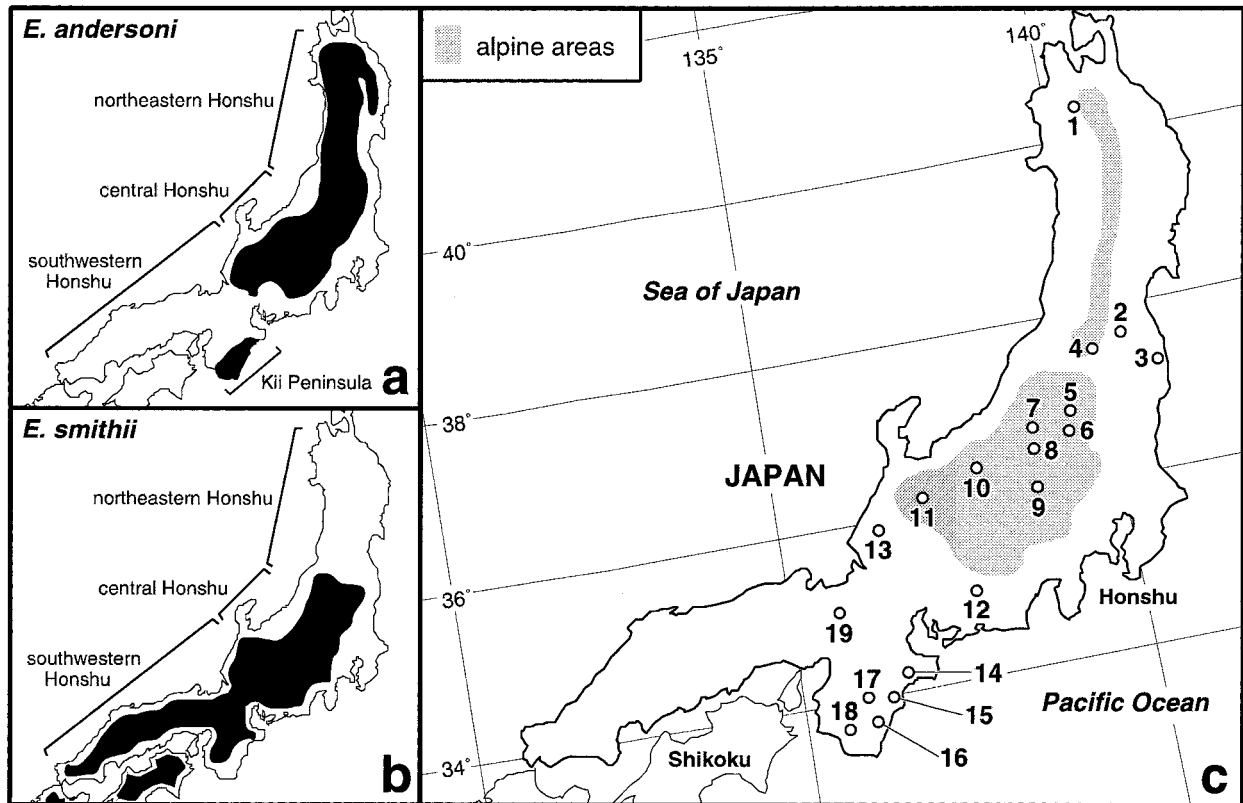

**Fig. 1.** Distributions of *Eothenomys andersoni* (a) and *E. smithii* (b). Solid areas indicate each horizontal distribution. Collection localities (c) of *Eothenomys* voles examined in this study. All locality numbers are identical to those in Table 1.

ries both restriction patterns. Therefore, Suzuki *et al.* (1999) hypothesized that the Kii Peninsula population of *E. andersoni* (cited as a valid species, *E. imaizumii*) originated via ancient hybridization between the ancestors of *E. andersoni* and *E. smithii*. The rDNA-RFLP provided reliable phylogenetic information because rDNA exists as a multi-gene family that consists of several hundred copies in the mammalian genome (Babu and Verma, 1985). In agreement with Suzuki *et al.* (1999), Iwasa *et al.* (1999) also suggested that the Kii Peninsula population of *E. andersoni* (cited as *E. imaizumii*) was derived from a cross-species event between the ancestors of the two species according to an analysis of meiotic chromosome behavior in their specific sex chromosomes based on observed synaptonemal complex.

There are still many taxonomic and phylogenetic questions concerning *E. andersoni* (Kaneko *et al.*, 1992; Kimura *et al.*, 1994, 1999; Suzuki *et al.*, 1999; Iwasa *et al.*, 1999; Iwasa, 2000; Iwasa and Tsuchiya, 2000; Iwasa and Suzuki, 2002a, b). In particular, it is thought that *E. andersoni* occurs in alpine areas in central Honshu (Imaizumi, 1960; Kaneko *et al.*, 1992; Abe *et al.*, 1994). However, a small population of an *andersoni*-like vole, which has not been identified, was discovered at quite low altitudes (<1,000 m) near Nagano, in central Honshu, in 1972 (cited as a *Eothenomys* sp. in Miyao *et al.*, 1979a, b). The voles from Nagano are smaller than *E. andersoni* from alpine regions (Miyao *et al.*, 1979a, b; Iwasa, 2000). In addition, the *E. andersoni* from Nagano

carried a *smithii*-like X chromosome and an *andersoni*-like Y chromosome (Iwasa, 1998; Iwasa *et al.*, 1999; Iwasa and Tsuchiya, 2000). The Y chromosomal features of the Nagano individuals were identical to those of *E. andersoni* from alpine regions in central Honshu (Iwasa and Tsuchiya, 2000). Based on karyological and morphological data, the individuals from Nagano (alt. 380–800 m) are tentatively regarded as *E. andersoni* (Iwasa, 2000; Iwasa and Tsuchiya, 2000). A few local populations of *E. andersoni* show genetic and morphologic differentiation; however, phylogenetic and taxonomic problems of such small relic populations of *E. andersoni* at lower altitudes still remain, as pointed out by some vole researchers (Kaneko, 1981, 1998; Kaneko *et al.*, 1992; Kimura *et al.*, 1994, 1999; Iwasa, 2000).

In this study, we analyzed three gene regions using Southern blotting for rDNA-RFLP and sequencing for the maternally inherited mitochondrial cytochrome *b* gene and paternally inherited Y chromosomal sex-determining gene. We reconsidered the evolution of *E. andersoni*, including Nagano individuals, and *E. smithii* in Honshu, which was hypothesized to be a hybridization event based on our previous studies (Iwasa *et al.*, 1999; Suzuki *et al.*, 1999; Iwasa and Tsuchiya, 2000; Iwasa and Suzuki, 2002a, b).

## MATERIALS AND METHODS

## Vole samples

Forty-five *Eothenomys* samples from Honshu were used for the phylogenetic analyses in this study (Table 1 and Fig. 1; Iwasa, 2000; Iwasa and Tsuchiya, 2000; Iwasa and Suzuki, 2002a). Spe-

cies identification was based on morphological characteristics (Kaneko *et al.*, 1992; Iwasa, 2000). Total DNA was prepared from liver tissue by proteinase K digestion, phenol-chloroform extraction, and ethanol precipitation. Fourteen specimens of both species were subject to rDNA-RFLP analysis. Mitochondrial cytochrome *b* (*Cytb*) gene sequences were determined for 12 specimens and the male

**Table 1.** Japanese *Eothenomys* specimens from Honshu examined in this study

Species	Collection locality <sup>#</sup>	Specimen No.	Sex	rDNA <sup>##</sup>	<i>Cytb</i> <sup>##</sup>	<i>Sry</i> <sup>##</sup>	
<i>E. andersoni</i>	Hirosaki, Aomori Pref. (1)	YO96Caa-3	m	Northeastern Honshu	mEan-1*	I*	
	Namie, Fukushima Pref. (3)	KT2694	m	–	mEan-2*	I*	
	Urabandai, Fukushima Pref. (4)	KT2704	m	–	mEan-3*	I*	
	Oze, Fukushima Pref. (5)	HEG97-98	f	Northeastern Honshu	mEan-4*	–	
		KT2734	f	–	mEan-5*	–	
		KT2737	f	–	mEan-6*	–	
	Nikko, Tochigi Pref. (6)	KT2690	m	–	mEan-7*	II*	
		KT2703	m	–	mEan-8*	II*	
	Mt. Yatsugatake, Nagano Pref. (9)	MH5037	m	–	mEan-9*	III*	
		HEG220-98	m	Central Honshu	mEan-10*	III*	
		HEG221-98	f	–	mEan-10*	–	
		HEG222-98	f	–	mEan-11*	–	
	Nagano, Nagano Pref. (10)	HEG223-98	m	–	mEan-10*	III*	
		KT3143	f	Nagano City	mEan-12	–	
		KT3144	m	–	mEan-13	III	
		KT3145	f	–	mEan-13	–	
		HEG164-98	f	Nagano City	mEan-13	–	
		HEG165-98	f	Nagano City	mEan-13	–	
		HEG166-98	m	Nagano City	mEan-13	III	
	Owase, Mie Pref. (15)	HEG167-98	m	Nagano City	mEan-14	III	
		MH4835	m	–	mEan-15*	IV*	
		YO95Ei-1	m	–	mEan-16*	V*	
		YO95Ei-2	m	–	mEan-17*	III*	
		YO95Ei-3	m	–	mEan-17*	III*	
	Kiwa, Mie Pref. (16)	ZS2541	f	–	mEan-18*	–	
		ZS2542	f	–	mEan-19*	–	
	Shimokitayama, Nara Pref. (17)	MH4834	m	–	mEan-20*	IV*	
	Kozagawa, Wakayama Pref. (18)	HEG96Ei-2	m	–	mEan-21*	V*	
		HEG96Ei-3	f	–	mEan-22*	–	
		HEG96Ei-4	f	–	mEan-21*	–	
		HEG96Ei-5	m	–	mEan-23*	V	
HEG96Ei-6		m	–	mEan-21	V		
HEG169-98		f	–	mEan-24*	–		
HEG176-98		m	–	mEan-25*	V		
HEG177-98		f	Kii Peninsula	mEan-15	–		
<i>E. smithii</i>		Ohtama, Fukushima Pref. (2)	HEG96Esk-1	m	–	mEsm-26*	VI*
		Oze, Fukushima Pref. (5)	HEG193-98	m	Central Honshu	mEsm-27*	VI*
	Shiga-Kougen, Nagano Pref. (7)	HEG225-98	m	Central Honshu	mEsm-28*	VI*	
	Tomioka, Gunma Pref. (8)	HEG224-98	m	Central Honshu	mEsm-29*	VI*	
	Ohyama, Toyama Pref. (11)	MAI-0260	m	–	mEsm-30	VI	
		MAI-0261	f	–	mEsm-31	–	
	Shitara, Aichi Pref. (12)	HEG111-98	m	–	mEsm-32*	VI	
	Matsuoka, Fukui Pref. (13)	YO94Ess-1	m	Southwestern Honshu	mEsm-33*	VI*	
	Miyagawa, Mie Pref. (14)	HEG96Ess-1	m	Kii Peninsula	mEsm-34	VI	
	Ashiu, Kyoto Pref. (19)	HS258	m	–	mEsm-35*	–	

<sup>#</sup>Each locality number in parenthesis is identical to that in Fig. 1.

<sup>##</sup>rDNA, retype based on RFLP for nuclear ribosomal RNA genes; *Cytb*, haplotype number of mitochondrial cytochrome b gene; *Sry*, haplotype based on Y chromosomal *Sry* sequences; –, no data.

\*Data from Iwasa and Suzuki (2002a).

sex-determining region of the Y chromosome (*Sry*) was sequenced in nine. These sequences were compared with other sequences from the databases (Iwasa and Suzuki, 2002a).

### Southern blotting for rDNA-RFLP

Total DNA from 14 specimens of both species was digested using nine restriction enzymes: *Aat*I (abbreviation=A), *Bam*HI (B), *Bgl*II (G), *Dra*I (D), *Eco*RI (E), *Pst*I (P), *Pvu*II (V), *Sac*I (S), and *Xba*I (X) (Fig. 2). The digested DNA was immobilized on nylon membranes and allowed to hybridize with digoxigenin-labeled (Roche DIG DNA Labeling and Detection Kit) rDNA probes (0.8 µg/ml), namely, 28S, 18SB, and INT (Fig. 2), derived from the BALB/c mouse (Suzuki *et al.*, 1994a, b; Iwasa *et al.*, 2001). The probes were detected on the membrane using material supplied with the kit.

To identify blotting band patterns, restriction maps for various rDNA repeating units (repeats) were constructed using restriction sites in the 18S, 5.8S, and 28S coding regions that are known to be conserved in mammals (Suzuki *et al.*, 1994a, b, 1999; Iwasa *et al.*, 2001). The restriction site maps were constructed from RFLP blotting patterns for the 5'-upstream external spacer region of the 18S gene (18S region), the 3'-downstream external spacer region of the 28S gene (28S region), and the internal spacer regions (ITS1 and 2) (Fig. 2).

### Direct sequencing of the mitochondrial *Cytb* gene

A fragment of the mitochondrial *Cytb* gene was amplified with universal primers (L14724 and H15915; Irwin *et al.*, 1991) in a primary PCR, followed by specific secondary PCR amplification with nested primers that were designed for voles (L14724, L15135, L15561, H15155, H15599, and H15919; Iwasa *et al.*, 2000). The PCR reactions were carried out according to Iwasa *et al.* (2000). Both DNA strands of the product of the second PCR were sequenced directly using a Dye Primer Cycle Sequencing Kit (ABI) and an automated sequencer (model 373A, ABI).

### Direct sequencing of the Y chromosomal *Sry* gene

A fragment of the *Sry* gene was amplified in a primary PCR with primers designed from human and murine sequences (SRY286 and HMG777, Table 1; Sinclair *et al.*, 1990; Suzuki *et al.*, 1997), followed by a secondary PCR with nested primers R-SRY306 and U-HMG597 (Suzuki *et al.*, 1997; Iwasa *et al.*, 2000; Iwasa and Suzuki, 2002a) to obtain an approximately 350-bp fragment of the flanking region of the HMG box. PCR reactions were also carried out according to Iwasa *et al.* (2000). The products of the secondary PCR were sequenced directly using the same methods as for the *Cytb* gene.

### Phylogenetic analyses

We constructed median-joining (MJ) network trees (Bandelt, 1994; Bandelt *et al.*, 1995, 1999) using the rDNA-RFLP data (0–1 matrix for all restriction sites), using the program Network 2.0 and setting the explicit parameter  $\epsilon = 0$  (Röhl, 1997) based on the maximum parsimony heuristic calculations (Farris, 1970).

A maximum likelihood (ML; Felsenstein, 1981) tree was constructed using the quartet-puzzling method (10,000 puzzling steps) with the program Tree-Puzzle ver. 5.0 (Strimmer and von Haeseler, 1996) from the *Cytb* data. The ML analysis was performed using the HKY algorithm (Hasegawa *et al.*, 1985) with unequal base frequencies and a discrete approximation to the gamma-distribution. The transition/transversion ratio, fraction of invariable sites, and shape parameter were estimated from the model. The mixed model of the heterogeneity rate (one invariable rate + eight gamma-distribution rates) was executed with the program (Strimmer and von Haeseler, 1996). To assess confidence, we used the quartet-puzzling scores (Strimmer and von Haeseler, 1996) for the ML tree. In addition, to confirm the relationships among all the *Cytb* haplotypes, a minimum-spanning tree was constructed according to the number of substitutions using ARLEQUIN ver. 2.000 (Schneider *et al.*, 2000).

The *Cytb* and *Sry* sequences of the specimens analyzed in

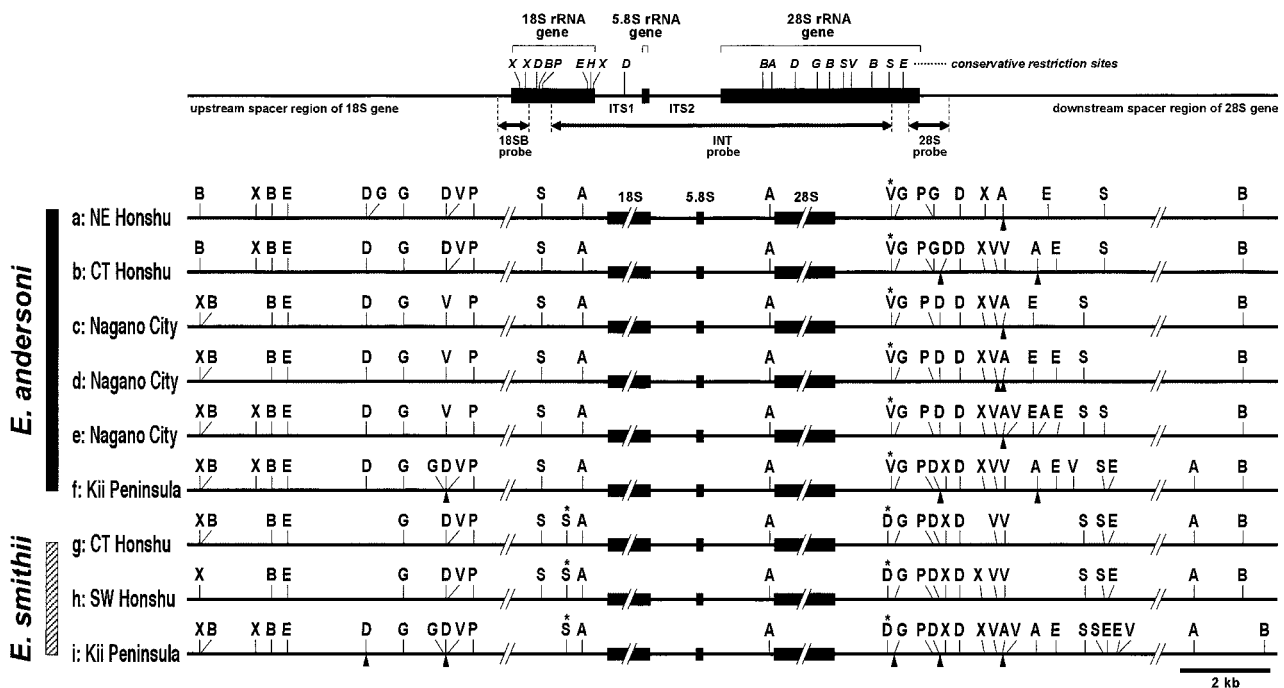

**Fig. 2.** Restriction maps of the major nine rDNA reotypes (a–i) for the external spacer region of upstream from 18S coding gene (A) and downstream from 28S coding gene (B). NE Honshu, northeastern Honshu; CT Honshu, central Honshu; SW Honshu, southwestern Honshu. Solid arrowheads indicate variable sites within the genome of a given reotype. Asterisk indicates completely different sites between *E. andersoni* and *E. smithii*.

Iwasa and Suzuki (2002a) were included in this study (GenBank/EMBL/DBJ accession numbers: AB037281-AB037316 (*Cytb*) and AB037317-AB037323 (*Sry*)). Our new *Cytb* data (mEan-12, 13, 14, 30, 31 and 34) were added to the DNA databases under accession numbers AB104503-AB104508.

## RESULTS

### Genetic cline from rDNA repetypes

Restriction maps were constructed from the rDNA-

RFLP patterns for the 14 *Eothenomys* specimens examined. In total, nine repetitive genotypes (repetypes) were detected, ignoring the size variation due to the insertion/deletion of small DNA fragments (a-i in Fig. 2). They were divided into seven groups: northeastern Honshu, central Honshu, Nagano, and the Kii Peninsula for *E. andersoni*, and central Honshu, southwestern Honshu, and the Kii Peninsula for *E. smithii* (Table 1 and Fig. 2).

The repetypes for *E. andersoni* and *E. smithii* consist-

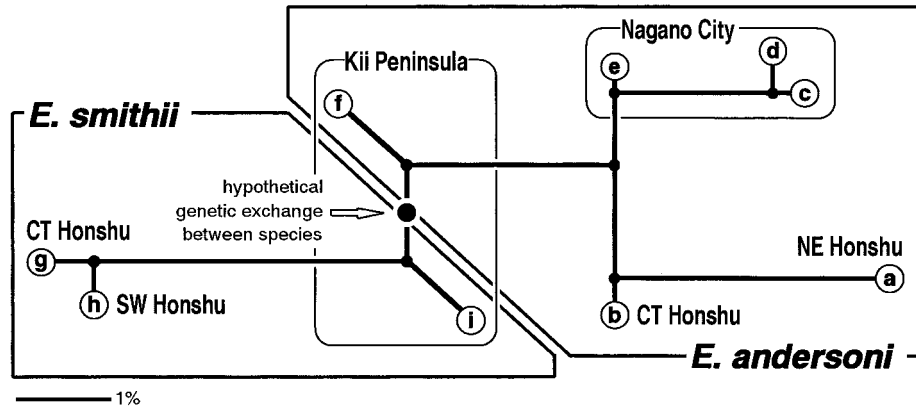

**Fig. 3.** Median-joining network tree based on the restriction site matrix by current rDNA-RFLP data. NE Honshu, northeastern Honshu; CT Honshu, central Honshu; SW Honshu, southwestern Honshu. Abbreviation of the nine repetypes (a-i) marked with open circles are the same those in Fig. 2. Small solid circles indicate hypothetical junction points. Branch lengths indicate distances based on the 0 1 distance matrix.

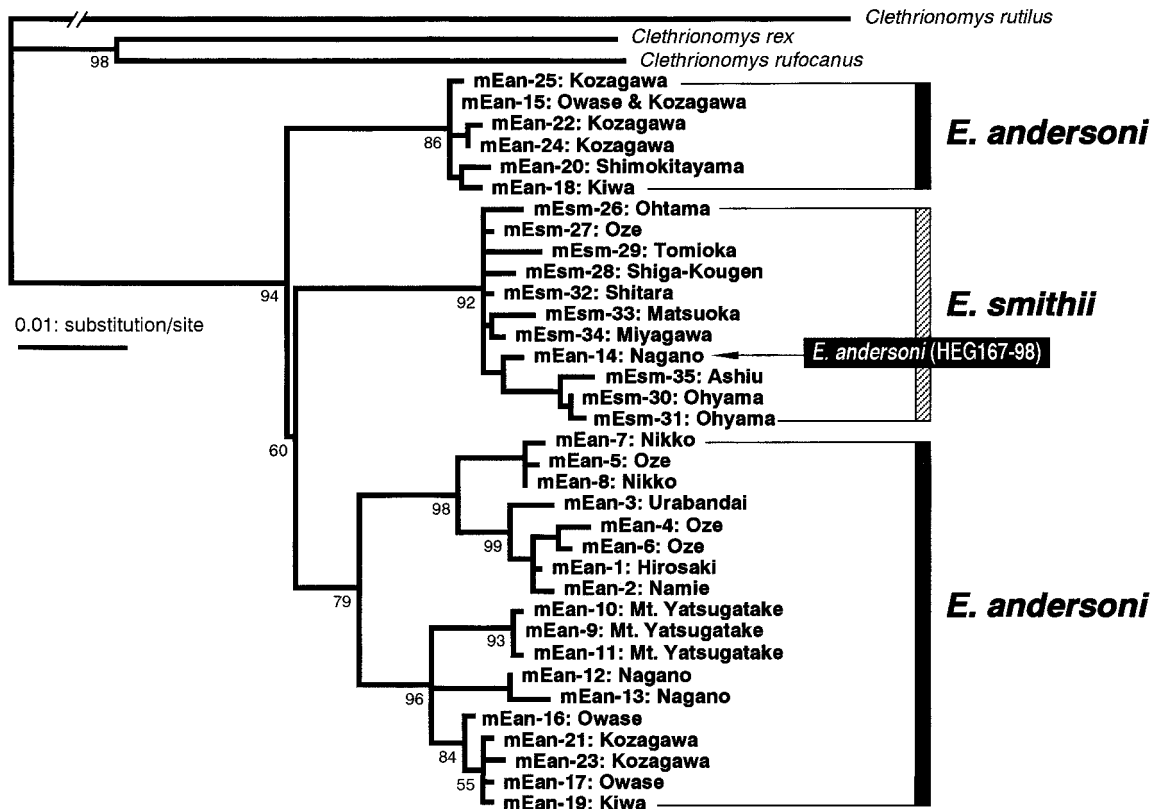

**Fig. 4.** Maximum likelihood tree based on the *Cytb* gene sequence data using quartet-puzzling method. Numbers near nodes of the tree are support values (>50%, 10,000 steps) to assign the confidences of nodes. All haplotype numbers are listed in Table 1.

tently differed by three restriction sites: site S in the 18S region, and sites D and V in the 28S region (Fig. 2). In addition, a comparison of the repetypes of *E. andersoni* from northeastern Honshu and *E. smithii* from central and southwestern Honshu identified differences at ten sites (sites A, D, S, and X in the 18S region, and sites A, D, G, S, V, and X in the 28S region; Fig. 2). *E. smithii* at the base of the Kii Peninsula possessed some locality-specific restriction patterns and, unexpectedly, shared the same variation with the adjacent population of *E. andersoni* from the Kii Peninsula at D, G, and X in the 18S region and A and E in the 28S region (Fig. 2). *Eothenomys andersoni* from central Honshu shared variable sites observed in *E. andersoni* from northeastern Honshu and the Kii Peninsula (sites G and X in the 18S region, and sites A, D, E, G, and V in the 28S region; Fig. 2). In *E. andersoni*, the restriction site patterns within the genome showed low variability in northeastern Honshu, intermediate variability in central Honshu, and high variability in the Kii Peninsula. The *E. andersoni* from Nagano had similar patterns, sharing several variable sites (sites A, E, S, and V in the 28S region; Fig. 2) with *E. andersoni* from central Honshu and the Kii Peninsula. By contrast, in *E. smithii*, only the individual from the Kii Peninsula repetype had a

higher level of variability than those from central and southwestern Honshu (Fig. 2).

The repetypes from the Kii Peninsula of both species showed a close relationship in the MJ tree that was constructed from the rDNA-RFLP data (Fig. 3). Similarly, the repetypes from northeastern and central Honshu of *E. andersoni* were closely related. The repetypes of *E. andersoni* from Nagano showed some affinity with the central Honshu *E. andersoni* (Fig. 3).

#### Intra- and interspecific relationships of *Cytb* sequences

Based on our previous work (Iwasa and Suzuki, 2002a) and the present *Cytb* data (Table 1), we constructed an ML tree ( $-\ln L=3370.01$ , unresolved quartets=10.5%, transition/transversion ratio=10.26, pyrimidine transition/purine transition ratio=2.09, gamma distribution parameter  $\alpha=0.15\pm 0.02$  SE) and a minimum spanning network tree (Figs. 4 and 5). Both trees included a single specimen of *E. andersoni* (HEG167-98; *Cytb* haplotype No. mEan-25) in the *E. smithii* group (*Cytb* haplotype mEsm series, Figs. 4 and 5). In addition, *E. andersoni* was subdivided into the following distinct local groups: the Kii Peninsula (two sub-groups), central Honshu, Nagano, and northeastern Honshu groups

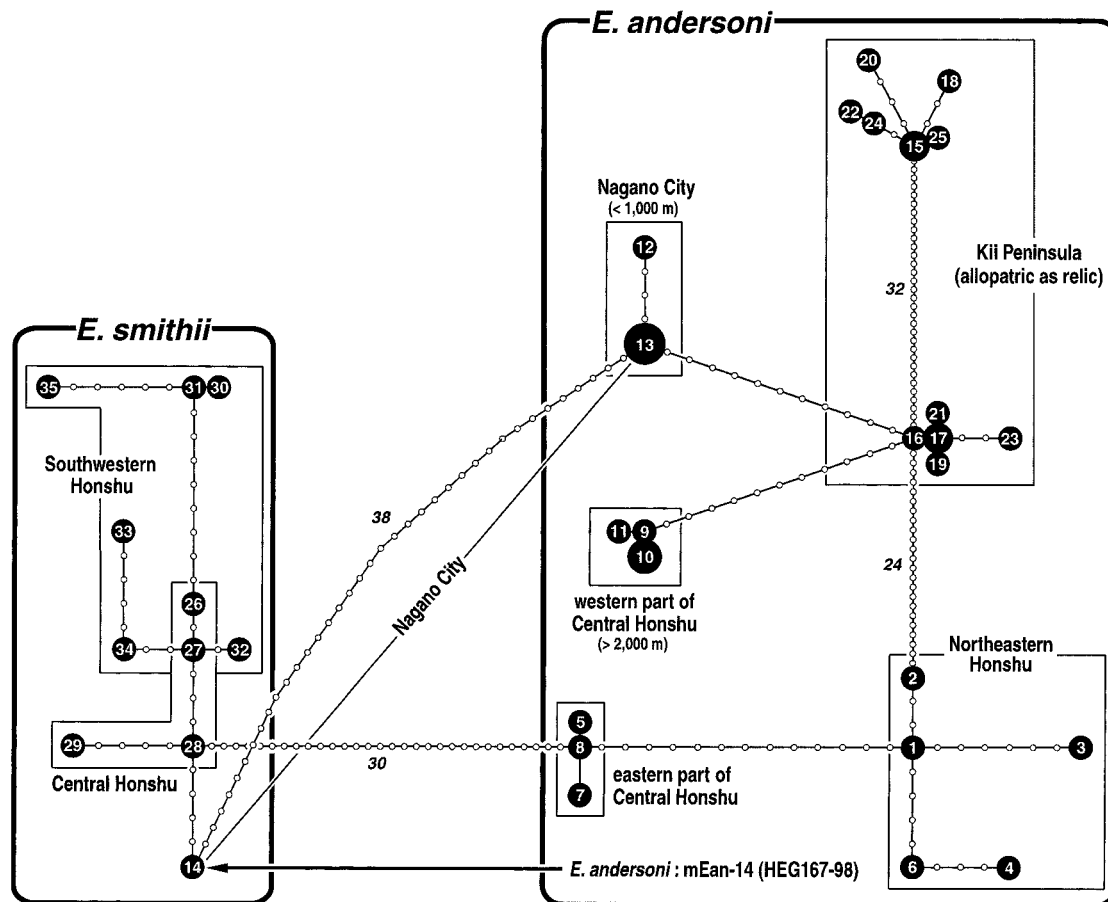

**Fig. 5.** Minimum spanning network tree based on the *Cytb* gene sequence data. All haplotype numbers are listed in Table 1. Number of open small circles along all branches mean number of substitutions between haplotypes connected. Branch lengths showing large number of substitutions (>20) are more reduced than actual genetic distances and number of substitutions are indicated by italicized numbers.

(Figs. 4 and 5). By contrast, *E. smithii* formed a single cluster in both trees (Figs. 4 and 5).

#### Intra- and interspecific relationships of the *Sry* sequences

Five distinct *Sry* haplotypes (I–V) were recognized after considering the sequence and size variation from previous (Iwasa and Suzuki, 2002a) and present analyses (Table 1). No variation within *E. smithii* was seen; a unique haplotype (VI) was recovered from all six males (Table 1; Iwasa and Suzuki, 2002a). The *Sry* sequences of both species contained a TG(TC)<sub>n</sub> repeat and a variable region in the central part, resulting in size variation ranging from 328 to 356 bp, identical to previous data in Iwasa and Suzuki (2002a). Two sequences with a single nucleotide substitution were observed in individuals from the western part of the central Honshu population of *E. andersoni*, although they are treated as one haplotype (III) here (Table 1).

In *E. andersoni*, the six variants of the *Sry* sequence showed specific geographic affinity (Table 1). Specimen HEG167-98 carrying the *smithii*-type *Cytb* sequence (mEan-14) had a typical *andersoni*-type *Sry* haplotype (III; Table 1) as well as karyological and morphological characteristics (Iwasa, 2000; Iwasa and Tsuchiya, 2000). In addition, the other specimens from Nagano had the same *Sry* haplotype (III; Table 1) as specimen HEG167-98. Considering Y chromosome criteria for *Eothenomys* voles (e.g., Iwasa, 1998; Iwasa and Tsuchiya, 2000), specimens with a small entirely heterochromatic Y chromosome, including specimen HEG167-98, carried the *andersoni*-type *Sry* haplotype and those bearing a medium-sized partially heterochromatic Y chromosome carried the *smithii*-type *Sry*, irrespective of the *Cytb* haplotype.

### DISCUSSION

Our previous studies revealed the complexity of the genomes of two Japanese *Eothenomys* species (Iwasa *et al.*, 1999; Suzuki *et al.*, 1999; Iwasa and Tsuchiya, 2000; Iwasa and Suzuki, 2002a, b). In particular, *E. andersoni* from Nagano and the Kii Peninsula exhibits locality-specific and unique features in its sex chromosomes and combinations of *Cytb* and *Sry* sequences (Iwasa and Tsuchiya, 2000; Iwasa and Suzuki, 2002a). In this study, we examined the nuclear rDNA variation in *Eothenomys* samples, including new specimens, and found concrete evidence for interspecific genic introgression between the sibling species *E. andersoni* and *E. smithii* during the course of evolution. Our findings suggest a specific mechanism for the generation and persistence of genetic diversity in small terrestrial organisms from Honshu, where there is topographic complexity over a broad range of latitude and a history of dramatic Quaternary climate changes.

Two phylogenetic markers, the mitochondrial *Cytb* gene and Y-chromosome *Sry* gene, which are both free from recombination, showed relatively marked genetic variation. By contrast, the nuclear rDNA-RFLP data showed less

genetic variation, although these data provide reliable information for assessing phylogenetic status because of the multiple genetic elements within a genome (ca. 500 copies), and the specific concerted evolution that drives sequence similarity within a genome and within the same reproductive population (Coen *et al.*, 1982). Distinct species differences were seen in *E. andersoni* and *E. smithii* at three restriction sites in the rDNA-RFLP array (Fig. 2). Using these mitochondrial and nuclear DNA markers, we reassessed the genetic make-up of local vole populations from Honshu, focusing on the samples of *E. andersoni* from the Kii Peninsula and Nagano.

The Kii Peninsula population of *E. andersoni*, which is separated from the main population in Honshu (Abe *et al.*, 1994; Mammalogical Society of Japan, 1997) and is sometimes treated as a valid species (*E. imaizumii*, e.g., Jameson, 1961), has intriguing genetic characteristics. The *Cytb* and *Sry* gene variation showed historic gene flow from the neighboring population of *E. andersoni* in central Honshu (Iwasa and Suzuki, 2002a), resulting in two haplotypes of gene markers: one specific to the Kii Peninsula and one similar to the neighboring populations. Conversely, the rDNA-RFLP suggests interspecific hybridization (Figs. 2 and 3; Suzuki *et al.*, 1999). Therefore, the Kii Peninsula population of *E. andersoni* likely has a hybrid origin, incorporating genetic elements from its sibling species, *E. smithii* (Fig. 3). This is consistent with our previous hypothesis based on a cytogenetic study, which showed that *E. andersoni* from the Kii Peninsula possessed a mixed type of sex chromosome variation that was thought to have originated from both species (Iwasa *et al.*, 1999; Iwasa and Tsuchiya, 2000). Although morphological and cytogenetical markers distinguish *E. smithii* from *E. andersoni* (Miyao, 1967; Iwasa, 2000; Iwasa and Tsuchiya, 2000), one *E. smithii* (HEG96Ess-1) from the base of the Kii Peninsula shared several restriction sites with *E. andersoni* from the Kii Peninsula in the rDNA-RFLP analysis (Kii Peninsula *E. smithii*; Figs. 2 and 3), implying that introgression of the rDNA elements occurred in both directions during the course of evolution in the Kii Peninsula and the adjacent area. Therefore, the data from the Kii Peninsula support the hypothesis (Iwasa and Suzuki, 2002a, b) that the evolution of Japanese vole species involves frequent introgression, both between conspecific local populations and between closely related species.

The seven *E. andersoni* from Nagano, in central Honshu, exhibited another complex genetic pattern. The *Sry* genotypes were the same as in *E. andersoni* from the Kii peninsula and alpine areas in central Honshu (Table 1). In contrast, the *Cytb* haplotype was an admixture of *E. andersoni* and *E. smithii* (Figs. 4 and 5), providing robust evidence for interspecific genetic exchange, although no *E. smithii* individuals have been trapped near Nagano (Morozumi and Miyao, 1974; Morozumi, 1977; Miyao *et al.*, 1979a, b; Morozumi and Morozumi, 1988; Iwasa, 2000; Iwasa and Tsuchiya, 2000). The rDNA-RFLP shows no sign of genetic



introgression and is the *E. andersoni* type, based on diagnostic variation in the three restriction sites mentioned above, although there are some changes (Figs. 2 and 3). The sequences of the *Cytb* gene from Nagano are also distinct, with approximately 1% genetic distance from the type for each species (Fig. 4), showing separation of the Nagano population from other conspecific and non-conspecific populations. Therefore, interspecific genome introgression occurred at some time in the past and the polymorphism in the mitochondrial DNA has been maintained (founder events; Mayr, 1963; Harrison, 1989). This postulate explaining the presence of historical interspecific introgression in the Nagano sample is in agreement with our previous studies of chromosomes (Iwasa and Tsuchiya, 2000) and X-linked gene sequences (Iwasa and Suzuki, b).

Our previous (Iwasa *et al.*, 1999; Iwasa and Tsuchiya, 2000; Iwasa and Suzuki, 2002a, b) and current data indicate that the evolutionary course of Japanese *Eothenomys* is puzzling and highly complex, countering initial expectations (Suzuki *et al.*, 1999). These complex patterns (Figs. 3, 4 and 5) are a consequence of complex evolutionary processes, such as past interspecific genome introgression, judging from intra- and interspecific gene divergence (Iwasa and Suzuki, 2002a). During the last glacial age, these vole species would not only have been split further into local populations with topographic changes arising from climatic change, but would have undergone genome introgression between the local populations (Iwasa and Suzuki, 2002a). Similar examples are seen in other Japanese small mammals, including shrews (Iwasa *et al.*, 2001; Ohdachi *et al.*, 1997, 2001, 2003; Motokawa *et al.*, 2000), shrew-moles (Harada *et al.*, 2001), moles (Tsuchiya *et al.*, 2000; Kawada *et al.*, 2001), and voles (Iwasa and Suzuki, 2002a, b; Iwasa *et al.*, 2000, 2002).

## ACKNOWLEDGMENTS

We are grateful to Dr. C. J. Conroy for his invaluable suggestion, and Dr. S.-I. Kawada for his help to my field work. Special thanks are also due to Drs. Y. Obara, Y. Kaneko, K. Tsuchiya, S.-I. Oda, E. Kitahara, Y. Kimura, M. Harada, Z. Shimizu, M. T. Kimura and S. D. Ohdachi for their encouragement throughout this study.

## REFERENCES

- Abe H, Ishii N, Kaneko Y, Maeda K, Miura S, Yoneda M (1994) A pictorial guide to the mammals in Japan. Tokai University Press, Tokyo (in Japanese)
- Babu A, Verma RS (1985) Structural and functional aspects of nuclear organizer regions (NORs) of human chromosome. *Int Rev Cytol* 94: 151–176
- Bandelt HJ (1994) Phylogenetic networks. *Verhandl Naturwiss Vereins Hamburg* 34: 51–71
- Bandelt HJ, Forster P, Röhl A (1999) Median-joining networks for inferring intraspecific phylogenies. *Mol Biol Evol* 16: 37–48
- Bandelt HJ, Forster P, Sykes BC, Richards MB (1995) Mitochondrial portraits of human populations using median networks. *Genetics* 141: 743–753
- Coen ES, Thoday JM, Dover GA (1982) Rate of turnover of structural variants in the rDNA gene family of *Drosophila melanogaster*. *Nature* 295: 564–568
- Farris JS (1970) Methods for computing Wagner trees. *Syst Zool* 19: 83–92
- Felsenstein J (1981) Evolutionary trees from DNA sequences: a maximum likelihood approach. *J Mol Evol* 17: 368–376
- Harada M, Ando A, Tsuchiya K, Koyasu K (2001) Geographical variations in chromosomes of the greater Japanese shrew-mole, *Urotrichus talpoides* (Mammalia: Insectivora). *Zool Sci* 18: 433–442
- Harrison RG (1989) Animal mitochondrial DNA as a genetic marker in population and evolutionary biology. *Trends Ecol Evol* 4: 6–11
- Hasegawa M, Kishino H, Yano T (1985) Dating of the human-ape splitting by a molecular clock of mitochondrial DNA. *J Mol Evol* 22: 160–174
- Imaizumi Y (1960) Colored Illustrations of the Mammals of Japan. Hoikusha, Osaka (in Japanese)
- Imaizumi Y (1979) Classification of the Japanese myomorphs. *Nat Anim* 9: 2–6 (in Japanese)
- Irwin DM, Kocher TD, Wilson AC (1991) Evolution of the cytochrome *b* gene of mammals. *J Mol Evol* 32: 128–144
- Iwasa MA (1998) Chromosomal and molecular variations in red-backed voles. *Honyurui Kagaku [Mammalian Science]* 38: 145–158 (in Japanese with English abstract)
- Iwasa MA (2000) Variation of skull characteristics in the Anderson's red-backed vole, *Eothenomys andersoni*, from Nagano City, central Honshu, Japan. *Mamm Stud* 25: 125–139
- Iwasa MA, Suzuki H (2002a) Evolutionary networks of maternal and paternal gene lineages in voles (*Eothenomys*) endemic to Japan. *J Mamm* 83: 852–865
- Iwasa MA, Suzuki H (2002b) Evolutionary significance of chromosome changes in northeastern Asiatic red-backed voles inferred from the aid of intron 1 sequences of the *G6pd* gene. *Chrom Res* 10: 419–428
- Iwasa MA, Tsuchiya K (2000) Karyological analysis of the *Eothenomys* sp. from Nagano City, central Honshu, Japan. *Chrom Sci* 4: 31–38
- Iwasa MA, Obara Y, Kitahara Y, Kimura Y (1999) Synaptonemal complex analysis in the XY chromosomes of six taxa of *Clethrionomys* and *Eothenomys* from Japan. *Mamm Stud* 24: 103–113
- Iwasa MA, Ohdachi S, Han SH, Oh HS, Abe H, Suzuki H (2001) Karyotype and RFLP of the nuclear rDNA of the *Crociodura* sp. on Cheju Island, South Korea. *Mammalia* 64: 451–459
- Iwasa MA, Kartavtseva IV, Dobrotvorsky AK, Panov VV, Suzuki H (2002) Local differentiation of the northern red-backed vole *Clethrionomys rutilus* (Rodentia, Arvicolinae) in northeastern Asia inferred from mitochondrial gene sequences. *Mamm Biol* 67: 157–166
- Iwasa MA, Utsumi Y, Nakata K, Kartavtseva IV, Nevedomskaya IA, Kondoh N, Suzuki H (2000) Geographic patterns of cytochrome *b* and *Sry* gene lineages in gray red-backed vole, *Clethrionomys rufocanus* (Mammalia, Rodentia) from Far East Asia including Sakhalin and Hokkaido. *Zool Sci* 17: 477–484
- Jameson Jr EW (1961) Relationships of the red-backed voles of Japan. *Pac Sci* 15: 594–604
- Kaneko Y (1981) External, cranial, and molar characters of red-backed vole collected from lower mountain areas in Nagano. *Ann Meet Zool Soc Japan, Abstract*, p 663 (in Japanese)
- Kaneko Y (1998) The taxonomic history of the genus *Eothenomys* based on morphological characteristics. *Honyurui Kagaku [Mammalian Science]* 38: 127–144 (in Japanese with English abstract)
- Kaneko Y, Nakashima T, Kimura Y (1992) Identification and vertical distribution of two species of *Eothenomys* on Ryo-Hakusan mountains, central Honshyu, Japan. *Bull Gifu Pref Mus* 11: 23–34 (in Japanese with English abstract)

- Kawada S, Harada M, Obara Y, Kobayashi S, Koyasu K, Oda S (2001) Karyosystematic analysis of Japanese talpine moles in the genera *Euroscaptor* and *Mogera* (Insectivora, Talpidae). *Zool Sci* 18: 1003–1010
- Kimura Y, Kaneko Y, Iwasa MA (1999) Identification and vertical distribution of two species of *Eothenomys* in the Oze district, northeastern Honshu, Japan. *Honyurui Kagaku* [Mammalian Science] 39: 257–268 (in Japanese with English abstract)
- Kimura Y, Kaneko Y, Yoshida T (1994) Small mammalian fauna in Adata mountain regions with special reference to genus *Eothenomys*. *Fukushima Seibutsu* 37: 13–19 (in Japanese)
- Kitahara E, Harada M (1996) Karyological identity of Anderson's red backed voles from the Kii Peninsula and central Honshu in Japan. *Bull Forestry Forest Prod Res Inst* 370: 21–30
- Mammalogical Society of Japan (ed.) (1997) Red data book of Japanese Mammals. Bunichi-Sogo Shuppan, Tokyo (in Japanese)
- Mayr E (1963) Animal species and evolution. Belknap Press, Cambridge
- Miyao T (1967) Similarity between the voles of Kii Peninsula and of northern part of Honshu. *Zool Mag* 76: 44–49 (in Japanese with English abstract)
- Miyao T, Morozumi T, Takada Y (1979a) A report of small mammal fauna of Nagano city, Honshu. *J Mamm Soc Jpn* 7: 305–310 (in Japanese with English abstract)
- Miyao T, Morozumi T, Morozumi M, Takada Y (1979b) A report of small mammal fauna on Mt. Iizuna, Nagano Pref. *J Mamm Soc Jpn* 7: 300–304 (in Japanese with English abstract)
- Morozumi T (1977) A continuation of small mammals from the Mt. Ohmine-san national forests in the vicinity of Nagano City. In "Nihon Honyurui Zakki vol. 4", Shinshu Honyurui Kenkyukai, Nagano, pp 20–24 (in Japanese)
- Morozumi T, Miyao T (1974) Small mammals from the Mt. Ohmine san national forests in the vicinity of Nagano City. In "Nihon Honyurui Zakki vol. 3", Shinshu Honyurui Kenkyukai, Nagano, pp 71–76 (in Japanese)
- Morozumi T, Morozumi M (1988) Animals in Shinshu. Shinano Kyouiku-kai Shuppan-bu, Nagano (in Japanese)
- Motokawa M, Suzuki H, Harada M, Lin LK, Koyasu K, Oda, SI (2000) Phylogenetic relationships among East Asian *Crociodura* (Mammalia: Insectivora) inferred from mitochondrial cytochrome *b* gene. *Zool Sci* 17: 497–504
- Ohdachi SD, Abe H, Han SH (2003) Phylogenetical positions of *Sorex* sp. (Insectivora, Mammalia) from Cheju Island and *S. caecutiens* from the Korean Peninsula, inferred from mitochondrial cytochrome *b* gene sequences. *Zool Sci* 20: 91–95
- Ohdachi S, Dokuchaev NE, Hasegawa M, Masuda R (2001) Intraspecific phylogeny and geographical variation of six species of northeastern Asiatic *Sorex* shrews based on the mitochondrial cytochrome *b* sequences. *Mol Ecol* 10: 2199–2213
- Ohdachi S, Masuda R, Abe H, Adachi J, Dokuchaev NE, Haukisalmi V, Yoshida MC (1997) Phylogeny of Eurasian soricine shrews (Insectivora, Mammalia) inferred from the mitochondrial cytochrome *b* gene sequences. *Zool Sci* 14: 527–532
- Röhl A (1997) Network. A program package for phylogenetic networks. Mathematisches Seminar, Universität Hamburg (available on request)
- Schneider S, Roessli D, Excoffier L (2000) ARLEQUIN, version 2.000. A Software for Population Genetics Data Analysis. University of Geneva, Geneva
- Sinclair AH, Berta P, Palmer MS, Hawkins JR, Griffiths BL, Smith MJ, Foster JW, Frischauf AM, Lovell-Badge R, Goodfellow PN (1990) A gene from the human sex-determining region encodes a protein with homology to a conserved DNA-binding motif. *Nature* 346: 240–244
- Strimmer K, von Haeseler A (1996) Quartet puzzling: a quartet maximum-likelihood method for reconstructing tree topologies. *Mol Biol Evol* 13: 964–969
- Suzuki H, Minato S, Sakurai S, Tsuchiya K, Folkin IM (1997) Phylogenetic position and geographic differentiation of the Japanese dormouse, *Glirulus japonicus*, revealed by variations among rDNA, mtDNA and the *Sry* gene. *Zool Sci* 14: 167–173
- Suzuki H, Tsuchiya K, Sakaizumi M, Wakana S, Sakurai S (1994a) Evolution of restriction sites of ribosomal DNA in natural populations of the field mouse, *Apodemus speciosus*. *J Mol Evol* 38: 107–112
- Suzuki H, Kawamoto Y, Takenaka O, Munechika I, Hori H, Sakurai S (1994b) Phylogenetic relationships among *Homo sapiens* and related species based on restriction site variations in rDNA spacers. *Biochem Genet* 32: 257–269
- Suzuki H, Iwasa M, Harada M, Wakana S, Sakaizumi M, Han SH, Kitahara E, Kimura Y, Kartavtseva I, Tsuchiya K (1999) Molecular phylogeny of red-backed voles in Far East Asia based on variation in ribosomal and mitochondrial DNA. *J Mamm* 80: 512–521
- Tsuchiya K (1981) On the chromosome variations in Japanese cricetid and murid rodents. *Honyurui Kagaku* [Mammalian Science], 42: 51–58 (in Japanese)
- Tsuchiya K, Suzuki H, Shinohara A, Harada M, Wakana S, Sakaizumi M, Han SH, Lin LK, Kryukov AP (2000) Molecular phylogeny of East Asian moles inferred from the sequence variation of the mitochondrial cytochrome *b* gene. *Genes Genet Sys* 75: 17–24

(Received February 28, 2003 / Accepted July 10, 2003)