



Remote Sensing of Riparian and Wetland Buffers: An Overview

Author: Klemas, Victor

Source: Journal of Coastal Research, 30(5) : 869-880

Published By: Coastal Education and Research Foundation

URL: <https://doi.org/10.2112/JCOASTRES-D-14-00013.1>

BioOne Complete (complete.BioOne.org) is a full-text database of 200 subscribed and open-access titles in the biological, ecological, and environmental sciences published by nonprofit societies, associations, museums, institutions, and presses.

Your use of this PDF, the BioOne Complete website, and all posted and associated content indicates your acceptance of BioOne's Terms of Use, available at www.bioone.org/terms-of-use.

Usage of BioOne Complete content is strictly limited to personal, educational, and non - commercial use. Commercial inquiries or rights and permissions requests should be directed to the individual publisher as copyright holder.

BioOne sees sustainable scholarly publishing as an inherently collaborative enterprise connecting authors, nonprofit publishers, academic institutions, research libraries, and research funders in the common goal of maximizing access to critical research.



REVIEW ARTICLES



www.cerf-jcr.org

Remote Sensing of Riparian and Wetland Buffers: An Overview

Victor Klemas

School of Marine Science and Policy
University of Delaware
Newark, DE 19716, U.S.A.
klemas@udel.edu

ABSTRACT

Klemas, V., 2014. Remote sensing of riparian and wetland buffers: an overview. *Journal of Coastal Research*, 30(5), 869–880. Coconut Creek (Florida), ISSN 0749-0208.

Forested riparian and wetland buffers can help protect stream water quality, provide wildlife habitat, preserve floodplains and wetlands, protect against erosion, and provide recreational value. Many waterways have no buffers or buffers that have been degraded by human activities, including agriculture and urban development. To plan, evaluate, and restore riparian buffers, wetland managers need to monitor the conditions of constantly changing buffers over time. Remote sensing offers a cost-effective monitoring approach. Because riparian and wetland buffer zones exhibit extreme variations in width, length, spatial complexity, soil, and vegetation cover, mapping their hydrology and land cover requires high-spatial- and high-spectral-resolution data. The recent availability of high-spatial-resolution satellite and high-spectral-resolution aircraft imagery has significantly improved the capacity for mapping riparian buffers, wetlands, and other ecosystems. However, satellite sensors still do not have the combined spatial and spectral resolution to reliably identify buffer vegetation types and conditions. New interpretation strategies need to be developed to maximize the information obtained from high-resolution satellite sensors while minimizing the problems specific to high-resolution imagery, such as high variability within scene elements and within scene objects. The objective of this article is to review applications of remotely sensed data for modeling, designing, and evaluating riparian and wetland buffers.

ADDITIONAL INDEX WORDS: *Vegetative buffers, stream buffers, buffer mapping, buffer change detection, hyperspectral mapping, runoff filtering, buffer modeling, buffer design, buffer restoration.*



www.JCRonline.org

INTRODUCTION

Riparian and wetland buffers are important for protecting water quality and wildlife but are often nonexistent or degraded by human activities. Buffers stabilize stream banks; absorb sediment, nutrients, and pesticides before they reach streams; moderate stream temperature and light levels; improve water quality for aquatic organisms; and provide habitat and natural corridors for terrestrial wildlife (Keeton, Kraft, and Warren, 2007; Kelly, Bothwell, and Schindler, 2003; Owers, Albanese, and Litts, 2012; Sweeney *et al.*, 2004; Wenger, 1999). Buffer protection and restoration are often achievable yet can be controversial when landowners have to give up strips of land for the creation of vegetated buffers. Nonetheless, creating buffers is more cost-effective when compared to other conservation practices, such as stream bank restoration (Alexander and Allen, 2006; Beechie, Pess, and Roni, 2008).

Constant changes caused by natural events and human activities create the need for monitoring the condition of riparian buffers over time. Buffer monitoring is also important for measuring the success of buffer restoration efforts, such as

the effort to restore thousands of miles of forested buffers in the Chesapeake Bay watershed (Claggett, Okay, and Stehman, 2010; Klemas, 2013c). The monitoring can be accomplished effectively using airborne and satellite remote sensing techniques, with the former more suitable for detailed studies in small areas and the latter appropriate for coarser assessment on large spatial scales (Lattin *et al.*, 2004).

The objective of this article is to review the application of airborne and satellite remote sensing techniques for mapping and modeling riparian and wetland buffers.

RIPARIAN AND WETLAND BUFFERS

Riparian buffers are transition zones between water and land that link terrestrial upland ecosystems to stream, river, lake, or wetland ecosystems. Buffers can be strips of grass, shrubs, or forest in streamside areas, sometimes reaching to the water's edge. Where forests occur along salt marshes, they serve as an important buffer between marsh and coastal development. Figure 1 shows the mixed herbaceous high marsh zone of a New Jersey salt marsh (foreground) and a neighboring freshwater hardwood swamp. A portion of the swamp is subject to infrequent flooding by storm tides. Vegetated buffers provide important functions, such as protecting and improving water quality, protecting wildlife habitat and biodiversity, preserving floodplains and wetlands,

DOI: 10.2112/JCOASTRES-D-14-00013.1 received 7 January 2014; accepted in revision 8 March 2014; corrected proofs received 7 April 2014; published pre-print online 29 May 2014.

© Coastal Education & Research Foundation 2014



Figure 1. Buffer boundary between a mixed herbaceous high marsh zone of a salt marsh and a neighboring freshwater hardwood swamp. Note the change of vegetation species across the boundary (R. Tiner, personal communication).

protecting against erosion, preserving stream characteristics, and providing recreational and aesthetic value. Buffers accomplish these tasks by slowing water runoff, trapping sediment, and enhancing water infiltration in the buffer. More specifically, buffers trap fertilizers, pesticides, bacteria, pathogens, and heavy metals, decreasing the chance that these pollutants will reach surface water or groundwater sources (Correll, 2005; Dillaha *et al.*, 1989; Lowrance, Leonard, and Sheridan, 1985; Mulamoottil, Warner, and McBean, 1996).

Despite their ecological importance, in many riparian zones the native vegetation has been destroyed and the adjacent waterways have been channelized, dammed, populated by exotic plants, and seriously polluted. Agricultural impacts include conversion of buffers to pasture or row crops, soil disturbance and bank destabilization by cattle, and ditches that bypass buffers (Schultz *et al.*, 2004). Impacts from forestry include removal of large canopy trees and soil disturbance. Development causes buffers to be lost or altered by new home sites, lawns, utility lines, paved trails, roads, bridges, boat

ramps, docks, parks, and sewer lines. The relative importance of these impacts varies with landscape context and their specific characteristics (*e.g.*, fertilizer application rates, type of forestry operation, and density of development).

Healthy riparian buffers are highly interactive with the adjacent waterways and provide many services to these waters. They should contain native plants that provide leaf litter and dissolved organic matter of the right type for desirable populations of invertebrates and microorganisms, which in turn support fish populations (Correll, 2005; Gregory *et al.*, 1991). Mature woody population can also provide a good supply of coarse woody debris that is important to stream channel morphology and fish habitat. By shading and evaporative cooling, forests play an important role in maintaining lower stream temperatures that can be essential to the life of native fish (Sinokrot and Stefan, 1993).

One of the most important services provided by riparian buffers strips is to act as water quality filters. Well-designed riparian buffers filter out contaminants from overland storm

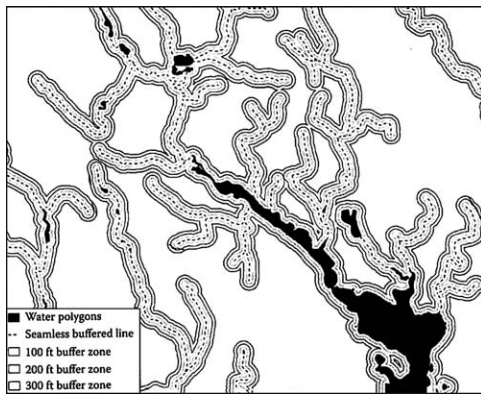

Figure 2. A planning map for riparian buffer zones of 100, 200, and 300 ft widths. Top is north. Note the buffers along headwater streams (Hurd *et al.*, 2010). Reprinted with permission from Taylor and Francis Group LLC through Copyright Clearance Center RightsLink.

flows and groundwater entering laterally and from stream channel waters flooding out into floodplains during storm events. For groundwater flows, the chief benefits are removal of nitrate and neutralization of excessive acidity (Correll and Weller, 1989). For lateral overland storm flows and outflows from the channel into the floodplain, the chief water quality benefit is removal of suspended sediments, pesticides, and various forms of nitrogen and phosphorus (Cooper *et al.*, 1987; Correll, Jordan, and Weller, 1992; Lowrance *et al.*, 1997; Mander, Kuusemets, and Ivask, 1995).

Water quality buffer effectiveness depends on its ability to delay or reduce flow velocities through the buffer, to reduce the stream power of overland flow, and to filter out pollutants, such as heavy metals, pesticides, and phosphorus, which are primarily transported in association with fine-grained sediments. The ability of the buffer to remove these pollutants is largely controlled by stream power. Other pollutants, such as bacterial pathogens and oxygen-demanding wastes, can be treated effectively by delaying flow, thus allowing time for die-off and decomposition. In some situations, specific biogeochemical processes such as denitrification are critical and require specific chemical, as well as hydrological, conditions (Phillips, 1994).

Figure 2 shows the location of buffer zones in a typical watershed. As shown, the most important locations to protect and restore riparian buffers are along the headwater streams (Hurd *et al.*, 2010). Furthermore, it is more effective for benefits such as nitrate removal from groundwater to have continuous but narrow riparian buffers rather than wider but intermittent buffers (Weller, Jordan, and Correll, 1998). Buffers on the shores of lakes are desirable but are less important than those on streams (Correll, 2005).

BUFFER DESIGN AND MODELING

When designing a riparian buffer, one must fully understand the hydrology of the site. If the site is a first- or second-order (small) stream, then lateral flows of overland storm flow and groundwater dominate. The buffer must be located to include the stream bank and areas where the water table is near the

surface. Groundwater often shows up in these areas as seeps. If the site is on a larger stream, then one must also plan for interactions with waters flooding out from the channel during storms (Correll, 2005; Delong and Brusven, 1991).

After humans have disrupted a buffer zone, reestablishment of a functional buffer may require the placement of appropriate subsoils and topsoils before planting on the site. Subsurface soils must have a suitable hydraulic conductivity for shallow groundwater to move with a reasonable transit time (Bosch *et al.*, 1994). Both surface and subsurface soils need enough organic matter to support high rates of microbial activity so that low oxidation and reduction potential is attained in the groundwater (Seitzinger, 1994). Infiltration rates of forest soil are about 10 times higher than those of grass turf areas and 40 times higher than those of a plowed field (Hanmer, 2005). Studies have shown about 30% to 90% reductions of nutrients, sediment, pesticides, and other pollutants in surface water and groundwater after passing through a riparian (streamside) forest (Hanmer, 2005).

Buffer regulations are generally complex, with buffer requirements varying by water body size, flow permanence, adjacent land use, slope, and other factors (Lee, Smyth, and Boutin, 2004). Typically, buffer width is one of the most critical aspects of riparian buffer design (Castelle, Johnson, and Conolly, 1994). Buffer width has received attention because it is enforceable from a regulatory standpoint and because wider buffers generally result in better stream protection. For instance, stream temperature, sedimentation, and nutrient pollution are known to decrease with increasing buffer width (Jones *et al.*, 2006; Lee, Smyth, and Boutin, 2004). However, if the buffer is too wide, the implementation cost may be too high and landowners may protest when asked to give up large strips of their land. Wenger (1999) recommended a minimum width of 100 ft for aquatic habitat protection, with wider buffers needed to account for steep slopes, impervious surfaces, and site-specific features such as wetlands or wide floodplains. The widths of existing riparian and wetland buffers range from 10 to 500 m, depending on the needs and hydrological, biological, and physical characteristics of the site. In many typical feasibility studies, buffer widths of 10, 30, and 100 m have been assumed (S. Antenen, personal communication).

When landowners wish to minimize the area of land to accomplish their water quality goals, they may use a three-zone approach for buffers on small streams. A narrow zone along the stream bank should be planted with native forest trees to provide shade, stream bank stability, woody debris, and leaf litter. A second wider native tree zone should extend from the edge of the first zone through land that has the water table at or near the surface to treat shallow groundwater by removing nitrates and acidity. The third narrow zone should extend a short distance upslope from the edge of the second zone. This zone should be carefully contoured to create sheet water flow during storms, and it should be planted in grass or other similar plants to trap suspended sediments, along with adhering nutrients and pesticides; assimilate dissolved nutrients into the plants; and bind dissolved pesticides (Correll, 2005). The U.S. Forest Service recommends that the first zone be about 4.5 m wide, the second zone be about 18 m wide, and the third zone be about 6 m wide (Welsch, 1991).

Decisions on buffer widths are often based on minimum separation distances that regulatory agencies specify between a sensitive area and the upland area generating the runoff loadings. Computer models are able to simulate the pollutant-trapping efficiency of buffer strips. These models can assist decision makers in selecting optimum buffer widths for specific situations. McKague, Cao, and Stephenson (1994) used the Chemicals, Runoff, and Erosion from Agricultural Management Systems model to assess the effectiveness of buffers in protecting a wetland located downslope from an adjacent proposed urban development site. Data sets were prepared describing both existing site conditions and midconstruction conditions. They identified buffer strips, which the model predicted would bring sediment loading rates during the midconstruction period down to levels matching the loading rates associated the existing site conditions. The modeling highlighted the importance of ensuring that the runoff from the upstream area enters the buffer strip as uniform sheet flow to maximize buffer strip efficiency. The modeling also identified points where sediment control techniques other than buffering were needed to fully protect the wetland from excess sediment loading as a consequence of urban construction activities (McKague, Cao, and Stephenson, 1994).

There have been simulation models for grass buffer strips (zone 3) for some time (Tolner, Barfield, and Hayes, 1982), but there are few simulation models for complete riparian buffers (Xiang, 1993). According to Correll (2005), it seems that one of the best developed and tested overall models for small stream, multizone buffer water quality functions is the Riparian Ecosystem Managements Model. A model for larger rivers and their floodplains shows promise but still needs to be tested in a variety of systems (Van der Peijl and Verhoeven, 1999). One of the problems is the lack of good, well-tested riparian zone simulation models suitable for coupling to geographic information system (GIS) data. Remotely sensed data have been important to efforts to model and design buffer zones. However, for small stream buffers, there is still the problem of inadequate spatial resolution of some remote sensors.

AIRBORNE MAPPING OF RIPARIAN BUFFERS

Airborne remote sensing, including film photography, has been used for at least 40 years for monitoring and inspecting riparian and wetland buffers, like it has been used in agriculture, forestry, and wetland mapping. An aerial picture of riparian buffers is shown in Figure 3. In this image of the Cottrell Salt Marsh near Stonington, Connecticut, neighboring fields and forests form a protective vegetative buffer between developed areas and the marsh. The marsh is a typical New England salt marsh dominated by high marsh species such as salt hay grass (*Spartina patens*), salt grass (*Distichlis spicata*), and the short form of smooth cordgrass (*Spartina alterniflora*). Vegetation and invertebrate studies have been conducted in this salt marsh (R. Tiner, personal communication).

More recently, airborne digital cameras have been used to accurately map wetlands, forest, and grass cover (Klemas, 2011). Riparian and wetland buffer zones exhibit extreme variations in width, length, spatial complexity, soil, and vegetation cover. Observing them often requires the ability to monitor their hydrology and land cover at high spatial and

temporal resolutions, provided mainly by active and passive remote sensors on aircraft and other airborne platforms (Klemas, 2013a). Even though high-spatial-resolution satellite data are available, the high-resolution and frequent, flexible overflights offered by airborne sensors are more suitable for a range of buffer planning, construction, and restoration applications. For instance, an aircraft overflight can be timed so as to view a wetland buffer during low tide to improve the detection of emergent and submerged aquatic vegetation.

Remote sensing aircraft are flown at high, medium, or low altitudes, depending on the resolution and coverage requirements. High-altitude flights covering large regions are normally performed by government agencies, whereas medium-altitude flights are often provided by private companies. Riparian buffers, wetland vegetation, hydrological features, shoreline positions, and dynamic features, such as flow patterns, are usually mapped from medium- or low-altitude flights (Hapke, 2010; Leatherman, Davison, and Nicholls, 1994). Low-altitude flights with small aircraft may also be used to supplement field data collection. The tradeoffs one must make in selecting flight altitudes and imaging systems are outlined in Figure 4. For instance, spatial resolution can be traded for coverage (swath width) by varying the flight altitude or the camera lens focal length (Avery and Berlin, 1992; Purkis and Klemas, 2011).

A major advance in aerial remote sensing has been the development of digital aerial cameras (Al-Tahir, Baban, and Ramlal, 2006). Digital photography is capable of delivering photogrammetric accuracy and coverage, as well as multispectral data, at any user-defined resolution down to a 0.1-m ground sampling distance. Thus, it provides photogrammetric positional accuracy with multispectral capabilities for image analysis and interpretation. Because no chemical film processing is needed, the direct digital acquisition can provide image data in a few hours compared to the weeks needed for a traditional film-based camera. Another advantage over traditional film is the ability to assess the quality of data taken in real time during the flight (Myers and Miller, 2005; Phinn, Stow, and Zedler, 1996). Airborne digital camera imagery can be integrated with global positioning system position information and used as layers in a GIS for a range of wetland mapping and modeling applications.

Airborne georeferenced digital cameras providing reflected visible to near-infrared digital imagery are particularly suitable for mapping riparian and wetland buffers. However, in regional or local studies of buffer change, time series may include aerial film photos obtained well before digital cameras became available (Mitch and Gosselink, 2007). The value of historical aerial photos and more recent digital camera images for studying wetland changes is demonstrated by several case studies in Klemas (2011).

To monitor riparian buffers through time, Owers, Albanese, and Litts (2012) developed a method to rapidly categorize buffer width and land use attributes. Using 2007 leaf-on aerial photography, they applied it to a 65-km section of the Toccoa River in north Georgia. The left and right banks of the Toccoa River were digitized as lines from the 2007 leaf-on digital photographs (National Agriculture Imagery Program's 1-m resolution imagery) in ArcView GIS 3.3 (Esri, Redlands,



Figure 3. Aerial view of the Cottrell Salt Marsh near Stonington, Connecticut, and neighboring fields and forests that form a protective vegetative buffer between development and marsh (R. Tiner, personal communication).

California, U.S.A.). Then, buffer lines were developed at 25, 50, and 100 ft from each digitized riverbank line and overlain on digital aerial photographs within ArcView. Using the buffer lines as a guide, the buffer width categories were visually classified based upon the extent of continuous tree canopy, and a new segment of the riverbank line was created each time the buffer width category changed. Aerial photographs were typically interpreted at scales between 1:3000 and 1:6000.

The protocol was repeated using 1999 leaf-off aerial photographs to assess the utility of the monitoring approach (Owers, Albanese, and Litts, 2012). About 45% of the length of the Toccoa River was bordered by buffers less than 50 ft wide in 2007, with agricultural and built-up lands having the smallest buffers. The percentage of river length in each buffer-width category changed little between 1999 and 2007, but they were

able to detect a 5% change of agricultural land use to built-up land use and 149 additional buildings within 100 ft of the river. Field verification indicated that their method overestimated buffer widths and forested land use and underestimated built-up land use. One source of error may be the time lag between imagery and field verification. The authors also feel that supplemental data, such as additional leaf-off imagery and road layers, would allow detection of the fine-scale impacts underestimated in their study.

Another major advance has been the application of hyperspectral imagers. Airborne hyperspectral imagers, such as the Advanced Visible Infrared Imaging Spectrometer and the Compact Airborne Spectrographic Imager, have been used successfully for mapping coastal wetlands and are being tested for riparian buffer mapping (Li, Ustin, and Lay, 2005; Ozesmi

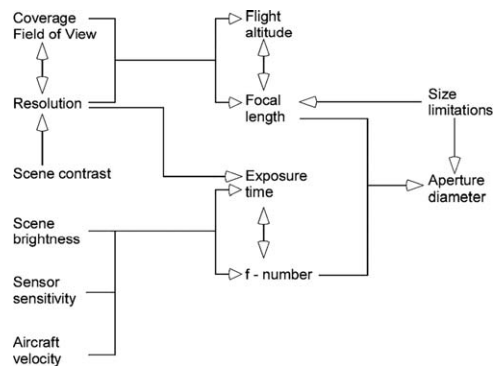

Figure 4. Aerial photography system tradeoffs. The most common tradeoff is among flight altitude, swath width, and spatial resolution.

and Bauer, 2002; Rosso, Ustin, and Hastings, 2005; Schmidt and Skidmore, 2003; Thomson *et al.*, 1998). Hyperspectral imagers may contain hundreds of narrow spectral bands located in the visible, near-infrared, midinfrared, and sometimes thermal portions of the electromagnetic spectrum.

The integration of hyperspectral imagery and elevation data derived from light detection and ranging (LIDAR) has further improved the accuracy of marsh vegetation mapping. For example, using LIDAR, hyperspectral and radar imagery, and narrowband vegetation indices, researchers have been able to not only discriminate some wetland species but also make progress on estimating biochemical and biophysical parameters of wetland vegetation, such as water content, biomass, and leaf area index (Adam, Mutanga, and Rugege, 2010; Artigas and Yang, 2006; Filippi and Jensen, 2006; Gilmore *et al.*, 2010; Klemas, 2013b; Ozesmi and Bauer, 2002; Pengra, Johnston, and Loveland, 2007; Schmidt *et al.*, 2004; Simard, Fatoyinbo, and Pinto, 2010; Wang, 2010). The hyperspectral images help distinguish high marsh from other salt marsh communities because of the former's high reflectance in the near-infrared region of the spectrum, and the LIDAR data help separate invasive *Phragmites* from low marsh plants (Yang and Artigas, 2006).

SATELLITE MAPPING OF BUFFERS

Detailed riparian buffer studies over small geographic areas are often performed using airborne digital or film cameras, including manual interpretation and automated analysis of the data (Lattin *et al.*, 2004; Valentine, 2002). However, for coarser assessment over large spatial scales, it is more cost-effective to use satellite imagery. Traditionally, the Land Satellite (Landsat) Thematic Mapper (TM) and the French Système Pour L'Observation de la Terre (SPOT) satellite have been reliable data sources for land cover mapping (Hewitt, 1990; Klemas, 2011; Rundquist, Narumalani, and Narayanan, 2001). Their respective 30- and 10- to 20-m spatial resolutions and spectral bands have proved effective for mapping wide riparian buffers, land cover, and changes in large coastal watersheds (Harvey and Hill, 2001; Houhoulis and Michener, 2000; Jensen, 2007; Klemas, 2013b; Lunetta and Balogh, 1999; Narumalani, Zhou, and Jensen, 1997).

An example of the early use of Landsat TM imagery to classify riparian buffers in the St. Jones River watershed in Delaware in 1993 is shown in Figure 5 (Klemas *et al.*, 2000). The Landsat TM classification at a 30-m resolution was unable to adequately identify the smaller hydrological features (*e.g.*, first- and second-order streams), which are important in nonpoint source runoff management. Therefore, U.S. Geological Survey hydrology data were used as the source of drainage information in the analysis. A 60-m search was calculated around this hydrology layer. A masking procedure was then used to extract the six buffer classes shown in Figure 5 that have a direct impact on the waterways: forested, agriculture, herbaceous (nonagriculture), bare (nonagriculture), disturbed or transitional, and developed (impervious).

In Figure 5, the green buffers are covered by natural vegetation and are considered healthy, while the red and yellow ones represent developed land (impervious) and agricultural fields, respectively, reaching nearly all the way to the water's edge. The analysis showed that 23.4-ha areas of headwaters and feeder streams were vulnerable. The natural vegetation cover in these impervious and agricultural buffers zones must be restored if the buffers are to be effective again (Klemas *et al.*, 2000). This procedure was applied to both the 1984 and the 1993 imagery for all watersheds in Delaware so that changes in riparian buffer status could be evaluated. The study showed that during that period, only about 67 ha of agricultural area were converted to forested buffers, yet approximately 1100 ha of forested buffer were lost to agriculture in the entire state.

Lade (1994) conducted one of the first investigations of riparian buffers in Maryland that showed the potential of Landsat TM imagery for buffer studies covering large areas. The results included the development of a statistical database that provided information on the adequacy of forest cover with 100- and 300-ft buffer zones calculated for digital streams and the creation of an attribute file that links this information with stream segments. Statewide forest delineations based on spectral signature analysis of Landsat TM data were used to determine adequate or inadequate forest cover within buffers. Determinations were made as to whether streams had adequate forest buffers, assuming that 100-ft buffer widths were needed to ensure adequate nonpoint pollution mitigation and 300-ft-wide buffers were needed to provide adequate riparian wildlife habitat. The assessment of forest cover within the buffer zones was performed by overlaying vectorized stream data over base rasters containing the classified Landsat TM imagery. Node points were set to indicate changes in the nature of the forest cover along the stream, and the accumulated mileage and attribute information were entered into a separate database, which became the basis of the statistical analysis.

Hardcopy maps were generated to visually display the Landsat TM forest delineations, as well as the 300-ft stream buffers, surface hydrology, road network, and pertinent place names for cultural and natural features (Lade, 1994). Color paper maps and Mylar overlays were generated at scales of 1:2400 and 1:62,500. Both the 100- and the 300-ft buffers were made available for onscreen viewing and manipulation using several GIS software packages. The maps provided a quick

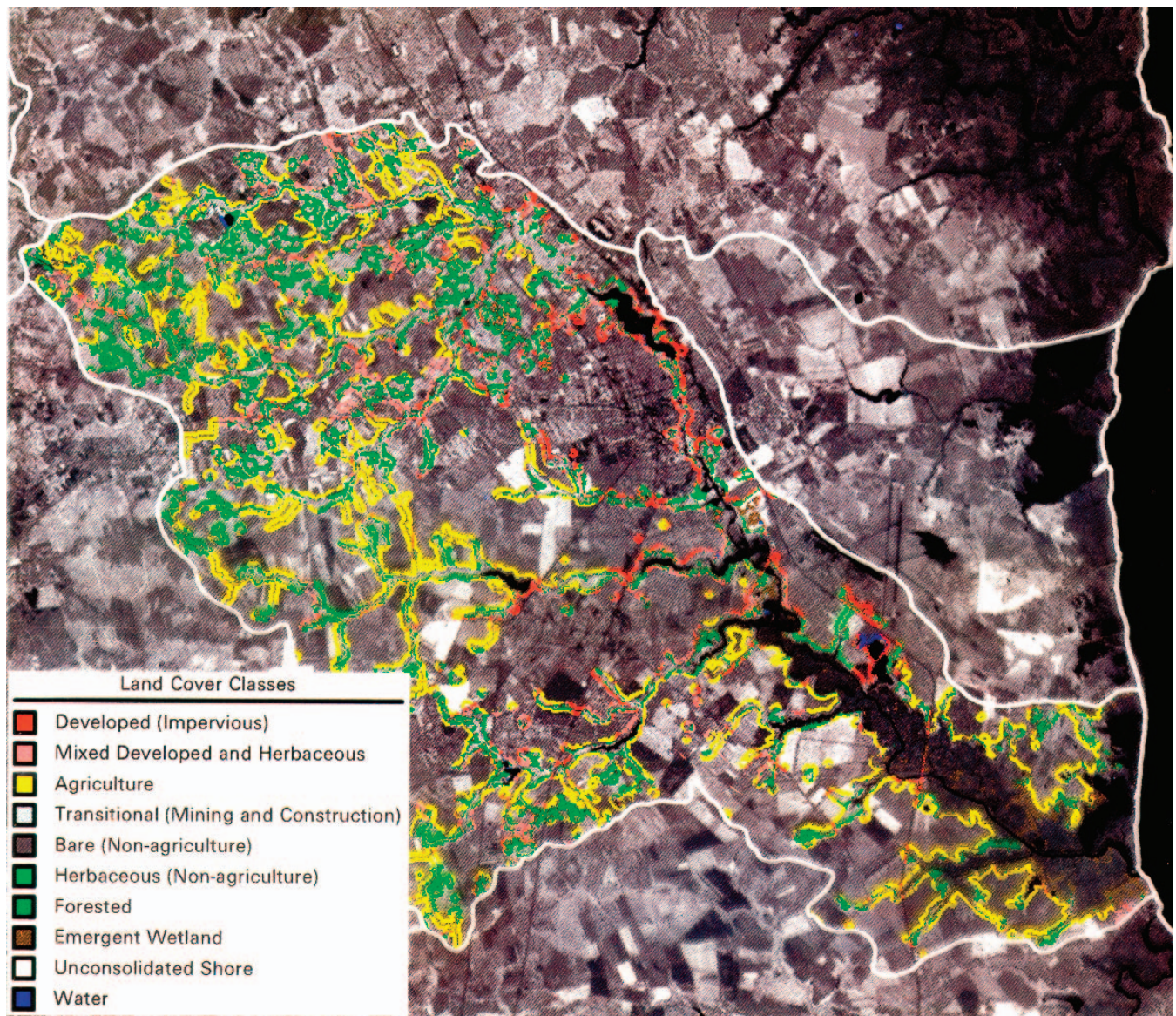

Figure 5. Classification of riparian buffers in the St. Jones, Delaware, watershed using 1993 Landsat TM imagery. North is up. As shown, all land within 60 m of the waterways was classified into six land cover categories, reflecting their effectiveness as buffers (Klemas *et al.*, 2000).

overview of the interpreted forests of the state and their relationship to observable ground features. The use of the data in a GIS permitted other layers of land use and land cover to be integrated into a complex analysis.

Detailed studies of riparian buffers with widths of less than 15 m require spatial resolutions on the order of 2 to 3 m. Congalton *et al.* (2002) developed a cost-effective method to classify riparian vegetation. They also compared maps generated using Landsat TM data with maps generated using aerial photography. Their forest classifications based on Landsat TM imagery did not do a good job identifying the structural characteristics of riparian vegetation compared to those based on aerial photography. The extreme diversity and linear

arrangement of the riparian vegetation creates classification problems and makes the Landsat TM imagery inadequate for use in policy decisions without additional data layers.

More recently, the availability of high-spatial- and high-spectral-resolution data has significantly improved the capacity for mapping riparian buffers, wetlands, and other ecosystems from space (Jensen *et al.*, 2007; Laba *et al.*, 2008; Ozesmi and Bauer, 2002). As shown in Table 1, high-resolution (0.4–4 m) imagery can be readily obtained from satellites, such as Ikonos and QuickBird. The finer spatial resolution comes at the cost of a narrower swath width (DigitalGlobe, 2003; Orbimage, 2003; Parkinson, 2003; Space Imaging, 2003).

Table 1. High-resolution satellite parameters and spectral bands (DigitalGlobe, 2003; Orbimage, 2003; Parkinson, 2003; Space Imaging, 2003).

Sponsor	Ikonos Space Imaging	QuickBird DigitalGlobe	OrbView-3 Orbimage	WorldView-1 DigitalGlobe	GeoEye-1 GeoEye	WorldView-2 DigitalGlobe
Launched	Sept. 1999	Oct. 2001	June 2003	Sept. 2007	Sept. 2008	Oct. 2009
Spatial resolution (m)						
Panchromatic	1.0	0.61	1.0	0.5	0.41	0.5
Multispectral	4.0	2.44	4.0	NA	1.65	2
Spectral range (nm)						
Panchromatic	525–928	450–900	450–900	400–900	450–800	450–800
Coastal blue	NA	NA	NA	NA	NA	400–450
Blue	450–520	450–520	450–520	NA	450–510	450–510
Green	510–600	520–600	520–600	NA	510–580	510–580
Yellow	NA	NA	NA	NA	NA	585–625
Red	630–690	630–690	625–695	NA	655–690	630–690
Red edge	NA	NA	NA	NA	NA	705–745
Near infrared	760–850	760–890	760–900	NA	780–920	770–1040
Swath width (km)	11.3	16.5	8	17.6	15.2	16.4
Off-nadir pointing	±26°	±30°	±45°	±45°	±30°	±45°
Revisit time (d)	2.3–3.4	1–3.5	1.5–3	1.7–3.8	2.1–8.3	1.1–2.7
Orbital altitude (km)	681	450	470	496	681	770

NA = not applicable.

To assess the utility of high-resolution satellite data for buffer studies, Goetz *et al.* (2003) analyzed Ikonos satellite imagery to map tree cover, impervious surface areas, and riparian buffer zone variables in relation to stream health ratings in the mid-Atlantic region of the United States. They found Ikonos precision-referenced data to be a resource for these applications and were able to achieve map accuracies comparable to manual aerial photo interpretation. They were able to use derived data sets for consistent assessment over areas that would be difficult to accomplish with traditional photographic mapping methods. For instance, they found that a stream health rating of excellent required no more than 6% impervious cover in the watershed and at least 65% tree cover in the riparian zone. A rating of good required less than 10% impervious and 60% tree cover. The authors had some problems with image acquisition logistics related to phenological and atmospheric conditions, shadowing within canopies and between scene elements, and limited spectral discrimination between cover types. Even though cost per unit area was significant, the project provided derived products to agencies in support of their planning and decision-making regulatory processes (Goetz *et al.*, 2003).

Johansen *et al.* (2007) applied high-spatial-resolution QuickBird imagery and coincident field data to classify riparian and forest ecosystems on Vancouver Island, British Columbia. Semivariograms were calculated to assess the separability of vegetation structural stages and to assess which spatial scales were most appropriate for calculation of gray-level co-occurrence texture measures to maximize structural class separation. The degree of spatial autocorrelation indicated that most vegetation structural types in the terrestrial ecosystem modeling scheme could be differentiated and that window sizes of 3×3 and 11×11 pixels were most appropriate for image texture calculations. Next, an object-oriented classification algorithm was applied to spectral and textural transformations of the QuickBird image data to map the structural vegetation classes. Using both spectral and textural image bands yielded the highest classification accuracy of 78.95%.

The inclusion of image texture increased the classification accuracies of vegetation structure by 2% to 19%. The results show that information on vegetation structure can be mapped effectively from high-spatial-resolution satellite image data (Johansen *et al.*, 2007).

Major plant species in complex, heterogeneous wetlands have been classified using multitemporal high-resolution QuickBird satellite images, field reflectance spectra, and LIDAR height information. *Phragmites*, *Typha* spp., and *S. patens* were spectrally distinguishable at particular times of the year, likely because of differences in biomass and pigments and the rate at which change occurred throughout the growing season. For instance, classification accuracies for invasive buffer species such as *Phragmites* were high because of the uniquely high near-infrared reflectance and height of this plant in early fall (Ghioca-Robrecht, Johnston, and Tulbure, 2008; Gilmore *et al.*, 2010; Laba *et al.*, 2008).

Hyperspectral imaging systems have been available not only for airborne applications but also in space. These include the EO-1 satellite-borne Hyperion system, which could detect fine differences in spectral reflectance, assisting in species discrimination globally (Brando and Decker, 2003; Christian and Krishnayya, 2009; Papes *et al.*, 2010; Pengra, Johnston, and Loveland, 2007). The Hyperion sensor provided imagery with 220 spectral bands at a spatial resolution of 30 m. Designed for only a limited life span, Hyperion was primarily used for technology demonstration and was somewhat limited for work in wetland environments by its rather large 30-m^2 pixel size. Although there have been few studies using satellite-based hyperspectral remote sensing to detect and map buffers and coastal vegetation species, results so far have shown that discrimination among multiple species is possible (Blasco, Aizpuru, and Din Ndongo, 2005; Heumann, 2011; Vaiphasa *et al.*, 2005).

Synthetic aperture radar (SAR) sensors on satellites provide the increased spatial resolution that is necessary in regional wetland and buffer mapping (Baghdadi *et al.*, 2001; Lang and McCarty, 2008; Novo *et al.*, 2002; Rosenqvist *et al.*, 2007;

Townsend, 2000, 2002). Water bodies scatter the beams from SAR sensors in other directions. Therefore, open water bodies appear dark because the radar pulses are not returned (backscattered) to the receiving antenna. If a wet surface is covered by vegetation, the radar pulses bounce between the vegetation and the wet surface and the backscattered return signal is stronger than it would have been if the surface were dry (Hess, Melack, and Simonett, 1990). The SAR sensors also allow one to distinguish between forested wetlands and upland forests and to discriminate other land cover types.

Drunpob and Chang (2006) used a combination of Radarsat-1 SAR and Landsat 5 TM data to detect changes in the riparian buffer zone of the Choke Canyon Reservoir watershed (CCRW) in South Texas by linking soil moisture variation with normalized difference vegetation index (NDVI) measurements. Because the CCRW is mostly agricultural and rangeland in a semiarid coastal environment, it provided the opportunity to study the interception capability of nonpoint source impact within the riparian buffer zone. First, an estimate of soil moisture using Radarsat-1 imagery was obtained. The radar images were captured in two acquisitions: April and September 2004. To improve the accuracy of the SAR imagery, radiometric and geometric calibrations were performed using five corner reflectors deployed by the Alaska Satellite Facility. Then two Landsat TM satellite images were summarized based on their NDVI. The SAR data showed how soil moisture and vegetation biomass vary in space and time in the CCRW, allowing identification of riparian buffer zone evolution over seasons. It was found that the seasonal soil moisture variation correlated with the NDVI values and that change detection in the buffer zone was technically feasible (Drunpob and Chang, 2006).

CONCLUSIONS

Riparian buffers are transition zones between water and land that link terrestrial upland ecosystems to stream, river, lake, or wetland ecosystems. Buffers can be strips of grass, shrubs, or forest in streamside areas. Vegetated buffers provide important functions, such as protecting and improving water quality, protecting wildlife habitat and biodiversity, preserving floodplains and wetlands, protecting against erosion, and providing recreational value. In many of the world's riparian zones, the native vegetation has been destroyed and the adjacent waterways have been channelized, dammed, populated by exotic plants, and seriously polluted.

Good management of upland drainage and careful design of stream buffers can protect the water quality of streams, lakes, and wetlands and provide most of the environmental services outlined earlier. Typically, buffer width is one of the most critical aspects of riparian buffer design. For instance, stream temperature, sedimentation, and nutrient pollution are known to decrease with increasing buffer width. The widths of existing riparian and wetland buffers range from 10 to 500 m, depending on the needs and hydrological, biological, and physical characteristics of the site. In typical feasibility studies, buffer widths of about 10, 30, and 100 m have been assumed. Buffers along small headwater streams are most important, and a continuous buffer is more effective than a wide but intermittent buffer.

The hydrology and soils of riparian buffers are basic to their function and must be emphasized when restoring the buffers. A functional buffer may require the placement of appropriate subsoils and topsoils before planting on the site. Infiltration rates of forest soil are about 10 times higher than those of grass turf areas and 40 times higher than those of a plowed field. An efficient use of lands adjacent to the smaller waterways seems to require three vegetation zones, each managed differently. For larger streams, it is important to protect and restore the floodplains.

There is a need not only to map vegetation cover in riparian zones but also to monitor the changes taking place, target restoration activities, and assess the success of previous management practices. Over large watersheds, traditional techniques based on aerial photos and field visits have not been cost-effective for meeting these objectives. Moderate resolution imagery from satellite sensors, such as Landsat TM, has been used to map relatively wide buffers in large watersheds.

Recent advances in remote sensing have significantly enhanced buffer zone management. Very-high-resolution satellite imagery is available that allows detailed mapping and monitoring of buffer zone vegetation cover, including forest cover, agriculture, and impervious surfaces. Airborne hyperspectral imagers are being used successfully for mapping coastal wetlands and are being tested for riparian buffer monitoring. The integration of hyperspectral imagery and LIDAR-derived elevation data has significantly improved the accuracy of mapping salt marsh vegetation.

New image analysis techniques using hyperspectral imagery and narrowband vegetation indices have been able to discriminate some wetland species and estimate biochemical and biophysical parameters of wetland and buffer vegetation, such as water content, biomass, and leaf area index. Radar-based remote sensing is another advance that provides even more detailed information on buffer zone properties, such as refined topographic derivatives, multidimensional vegetation structure, and soil moisture. An earlier review of remote sensing techniques and future prospects for riparian buffer mapping has been provided by Goetz (2006).

There remains an urgent need to further improve remote sensing techniques for riparian buffer management. Satellite sensors still do not have the combined spatial and spectral resolution needed to identify buffers, their vegetation cover, and their conditions. High-resolution satellite sensors have difficulty in adequately discriminate some land cover types because of high-spatial variability within scene elements resulting from variable illumination and viewing conditions. Spectral variability within scene objects contributes to reduced class-type discrimination between generalized land cover types, such as deciduous forest and some agricultural crops. New interpretation strategies need to be developed to maximize the information obtained from high-resolution satellite sensors while minimizing the problems specific to high-resolution imagery.

LITERATURE CITED

Adam, E.; Mutanga, O., and Rugege, D., 2010. Multispectral and hyperspectral remote sensing for identification and mapping of

- wetland vegetation: A review. *Wetlands Ecology and Management*, 18, 281–296.
- Alexander, G.G. and Allen, J.D., 2006. Stream restoration in the upper Midwest, U.S.A. *Restoration Ecology*, 14(4), 595–604.
- Al-Tahir, A.; Baban, S.M.J., and Ramlal, B., 2006. Utilizing emerging geo-imaging technologies for the management of tropical coastal environments. *West Indian Journal of Engineering*, 29, 11–22.
- Artigas, F.J. and Yang, J., 2006. Spectral discrimination of marsh vegetation types in the New Jersey meadowlands, USA. *Wetlands*, 26, 271–277.
- Avery, T.E. and Berlin, G.L., 1992. *Fundamentals of Remote Sensing and Airphoto Interpretation*, 5th edition. New York: Macmillan, 472p.
- Baghdadi, N.; Bernier, M.; Gauthier, R., and Neeson, I., 2001. Evaluation of C-band SAR data for wetlands mapping. *International Journal of Remote Sensing*, 22, 71–88.
- Beechie, T.; Pess, G., and Roni, P., 2008. Setting river restoration priorities: A review of approaches and a general protocol for identifying and prioritizing actions. *North American Journal of Fisheries Management*, 28, 891–905.
- Blasco, F.; Aizpuru, M., and Din Ndongo, D., 2005. Mangroves remote sensing. In: Schwartz, M.L. (ed.), *Encyclopedia of Coastal Science*. Dordrecht, The Netherlands: Springer, pp. 614–617.
- Bosch, D.D.; Hubbard, R.K.; West, L.T., and Lowrance, R.R., 1994. Subsurface flow patterns in a riparian buffer system. *Transactions of the American Society of Agricultural Engineering*, 37, 1783–1790.
- Brando, V.E. and Decker, A.G., 2003. Satellite hyperspectral remote sensing for estimating estuarine and coastal water quality. *IEEE Transactions on Geoscience and Remote Sensing*, 41, 1378–1387.
- Castelle, A.J.; Johnson, A.W., and Conolly, C., 1994. Wetland and stream buffer size requirement: A review. *Journal of Environmental Quality*, 23, 878–882.
- Christian, B. and Krishnayya, N.S.R., 2009. Classification of tropical trees growing in a sanctuary using Hyperion (EO-1) and SAM algorithm. *Current Science*, 96, 1601–1607.
- Claggett, P.R.; Okay, J.A., and Stehman, S.V., 2010. Monitoring regional riparian forest cover change using stratified sampling and multi-resolution imagery. *Journal of the American Water Resources Association*, 46, 334–343.
- Congalton, R.G.; Birch, K.; Jones, R., and Schriever, J., 2002. Evaluating remotely sensed techniques for mapping riparian vegetation. *Computers and Electronics in Agriculture*, 37, 113–126.
- Cooper, J.R.; Gilliam, J.W.; Daniels, R.B., and Robarge, W.P., 1987. Riparian areas as filters for agricultural sediment. *Soil Science Society of America Journal*, 51, 416–420.
- Correll, D.L., 2005. Principles of planning and establishment of buffer zones. *Ecological Engineering*, 24, 433–439.
- Correll, D.L.; Jordan, T.E., and Weller, D.E., 1992. Nutrient flux in a landscape: Effects of coastal land use and terrestrial community mosaic on nutrient transport to coastal waters. *Estuaries*, 15, 431–442.
- Correll, D.L. and Weller, D.E., 1989. Factors limiting processes in freshwater wetlands: An agricultural primary stream riparian forest. In: Sharitz, R.R. and Gibbons, J.W. (eds.), *Freshwater Wetlands and Wildlife*. Oak Ridge, Tennessee: U.S. Department of Energy, pp. 9–23.
- Delong, M.D. and Brusven, M.A., 1991. Classification and spatial mapping of riparian habitat with applications to streams impacted by nonpoint source pollution. *Environmental Management*, 15, 565–571.
- DigitalGlobe, 2003. *QuickBird Imagery Products and Product Guide*, revision 4. Longmont, Colorado: DigitalGlobe, 4p.
- Dillaha, T.A.; Reneau, R.B.; Mostaghimi, S., and Lee, D., 1989. Vegetative filter strips for agricultural non-point source pollution control. *Transactions of the American Society of Agricultural Engineers*, 32, 513–519.
- Drunpob, A. and Chang, N.B., 2006. Riparian buffer zone change detection based on Radarsat-1 and Landsat satellite images. In: Graham, R. (ed.), *Proceedings of the World Environmental and Water Resources Congress* (Omaha, Nebraska, American Society of Civil Engineers), 21–25 May 2006. [http://dx.doi.org/10.1061/40856\(200\)212](http://dx.doi.org/10.1061/40856(200)212).
- Filippi, A.M. and Jensen, J.R., 2006. Fuzzy learning vector quantization for hyperspectral coastal vegetation classification. *Remote Sensing of Environment*, 100, 512–530.
- Ghioca-Robrecht, D.M.; Johnston, C.A., and Tulbure, M.G., 2008. Assessing the use of multiseason QuickBird imagery for mapping invasive species in a Lake Erie coastal marsh. *Wetlands*, 28, 1028–1039.
- Gilmore, M.S.; Civco, D.L.; Wilson, E.H.; Barrett, N.; Prisloe, S.; Hurd, J.D., and Chadwick, C., 2010. Remote sensing and in situ measurements for delineation and assessment of coastal marshes and their constituent species. In: Wang, J. (ed.), *Remote Sensing of Coastal Environments*. Boca Raton, Florida: CRC, pp. 261–280.
- Goetz, S.J., 2006. Remote sensing of riparian buffers: Past progress and future prospects. *Journal of the American Water Resources Association*, February, , 133–143.
- Goetz, S.J.; Wright, R.K.; Smith, A.J.; Zinecker, E., and Schaub, E., 2003. Ikonos imagery for resource management: Tree cover, impervious surfaces, and riparian buffer analyses in the mid-Atlantic region. *Remote Sensing of Environment*, 88, 195–208.
- Gregory, S.V.; Swanson, F.J.; McKe, W.A., and Cummins, K.W., 1991. An ecosystem perspective of riparian zones. *BioScience*, 41, 540–551.
- Hanmer, R., 2005. Streamside buffer efforts need to branch out. *Chesapeake Bay Journal*, December, pp. 23–24.
- Harvey, K.R. and Hill, J.E., 2001. Vegetation mapping of a tropical freshwater swamp in the Northern Territory, Australia: A comparison of aerial photography, Landsat TM and SPOT satellite imagery. *Remote Sensing of Environment*, 22, 2911–2925.
- Hess, L.; Melack, J., and Simonett, D., 1990. Radar detection of flooding beneath the forest canopy: A review. *International Journal of Remote Sensing*, 11, 1313–1325.
- Heumann, B.W., 2011. Satellite remote sensing of mangrove forests: Recent advances and future opportunities. *Progress in Physical Geography*, 35, 87–108.
- Hewitt, M.J., 1990. Synoptic inventory of riparian ecosystems: The utility of Landsat Thematic Mapper. *Forest Ecosystem Management*, 33/34, 605–620.
- Houhoulis, P. and Michener, W., 2000. Detecting wetland change: A rule-based approach using NWI and SPOT-XS data. *Photogrammetric Engineering and Remote Sensing*, 66, 205–211.
- Hurd, J.D.; Civco, D.L.; Wilson, E.H., and Arnold, C.L., 2010. Coastal area land-cover change analysis for Connecticut. In: Wang, J. (ed.), *Remote Sensing of Coastal Environments*. Boca Raton, Florida: CRC, pp. 333–354.
- Jensen, J.R., 2007. *Remote Sensing of the Environment: An Earth Resource Perspective*. Upper Saddle River, New Jersey: Pearson Prentice Hall, 592p.
- Jensen, R.R.; Mausel, P.; Dias, N.; Gonsler, R.; Yang, C.; Everitt, J., and Fletcher, R., 2007. Spectral analysis of coastal vegetation and land cover using AISA+hyperspectral data. *Geocarto International*, 22, 17–28.
- Johansen, K.; Coops, N.C.; Gergel, S.E., and Stange, Y., 2007. Application of high spatial resolution satellite imagery for riparian and forest ecosystem classification. *Remote Sensing of Environment*, 110, 29–44.
- Jones, K.L.; Poole, G.C.; Meyer, J.L.; Bumback, W., and Kramer, E.A., 2006. Quantifying expected ecological response to natural resource legislation: A case study of riparian buffers aquatic habitat, and trout populations. *Ecology and Society*, 11(2), 1–15.
- Keeton, W.S.; Kraft, C.E., and Warren, D.R., 2007. Mature and old-growth riparian forests: Structure, dynamics and effects on Adirondack stream habitats. *Ecological Applications*, 17(3), 852–868.
- Kelly, D.J.; Bothwell, M.L., and Schindler, D.W., 2003. Effects of solar ultraviolet radiation on stream communities: An intersite comparison. *Ecology*, 84(10), 2724–2740.

- Klemas, V., 2011. Remote sensing of wetlands: Case studies comparing practical techniques. *Journal of Coastal Research*, 27, 418–442.
- Klemas, V., 2013a. Airborne remote sensing of coastal features and processes: An overview. *Journal of Coastal Research*, 29, 239–255.
- Klemas, V., 2013b. Remote sensing of wetland biomass: An overview. *Journal of Coastal Research*, 29, 1016–1028.
- Klemas, V., 2013c. Using remote sensing to select and monitor wetland restoration sites: An overview. *Journal of Coastal Research*, 29, 958–970.
- Klemas, V.; Knecht, R.W.; Cicin-Sain, B.; Yan, X.-H.; Field, R.T.; Weatherbee, O.; Price, K.S.; Badiey, M.; Wong, K.C., and Zheng, Q., 2000. In: Gutierrez, J. (ed.), *Improving the Management of Coastal Ecosystems through Management Analysis and Remote Sensing/GIS Applications: Experiences from the Delaware Region*. Seagrant Report. Newark, Delaware: University of Delaware, pp. 1–271.
- Laba, M.; Downs, R.; Smith, S.; Welsh, S.; Neider, C.; White, S.; Richmond, M.; Philpot, W., and Baveye, P., 2008. Mapping invasive wetland plants in the Hudson River National Estuarine Research Reserve using QuickBird satellite imagery. *Remote Sensing of Environment*, 112, 286–300.
- Lade, K.P., 1994. *Stream Buffer Characterization: Landsat TM and SPOT Panchromatic Data Analysis of 100- and 300-Foot Riparian Buffers in the State of Maryland*. IP&RSC Technical Paper, July 7. Salisbury, Maryland: Salisbury State University, 4p.
- Lang, M.W. and McCarty, G.W., 2008. Remote sensing data for regional wetland mapping in the United States: Trends and future prospects. In: Russo, R.E. (ed.), *Wetlands: Ecology, Conservation and Restoration*. Hauppauge, New York: Nova Science, pp. 73–112.
- Lattin, P.D.; Wigington, P.J.; Moser, T.J.; Peniston, B.E.; Lindeman, D.R., and Oetter, D.R., 2004. Influence of remote sensing imagery source on quantification of riparian land cover. *Journal of the American Water Resources Association*, 40, 215–227.
- Leatherman, S.P.; Davison, A.T., and Nicholls, R.J., 1994. Coastal geomorphology. In: Commission on Geosciences, Environment and Resources (eds.), *Environmental Science in the Coastal Zone: Issues for Further Research*. Washington, DC: National Academy Press, pp. 1–172.
- Lee, P.; Smyth, C., and Boutin, S., 2004. Quantitative review of riparian buffer width guidelines from Canada and the United States. *Journal of Environmental Management*, 70, 165–180.
- Li, L.; Ustin, S.L., and Lay, M., 2005. Application of multiple endmember spectral mixture analysis (MESMA) to AVIRIS imagery for coastal salt marsh mapping: A case study in China Camp, CA, USA. *International Journal of Remote Sensing*, 26, 5193–5207.
- Lowrance, R.; Leonard, R., and Sheridan, J., 1985. Managing riparian ecosystems to control nonpoint pollution. *Journal of Soil and Water Conservation*, January/February, 87–91.
- Lowrance, R.; Vellidis, G.; Wauchope, R.D.; Gay, P., and Bosch, D.D., 1997. Herbicide transport in a managed riparian forest buffer system. *Transactions of the American Society of Agricultural Engineers*, 40, 1047–1057.
- Lunetta, R.S. and Balogh, M.E., 1999. Application of multi-temporal Landsat 5 TM imagery for wetland identification. *Photogrammetric Engineering and Remote Sensing*, 65, 1303–1310.
- Mander, U.; Kuusemets, V., and Ivask, M., 1995. Nutrient dynamics of riparian ecotones: A case study from the Porijogi River catchment, Estonia. *Landscape and Urban Planning*, 31, 333–348.
- McKague, K.J.; Cao, J.Z., and Stephenson, D.E., 1994. The CREAMS model for evaluating the effectiveness of buffer strips in reducing sediment loads to wetlands. In: Mulamootil, G.; Warner, B.G., and McBean, E.A. (eds.), *Wetlands: Environmental Gradients, Boundaries and Buffers*. Boca Raton, Florida: CRC, pp. 251–261.
- Mitch, W.J. and Gosselink, J.G., 2007. *Wetlands*, 4th edition. New York: Wiley, 582p.
- Mulamootil, G.; Warner, B.G., and McBean, E.A. (eds.), 1996. *Wetlands, Environmental Gradients, Boundaries, and Buffers*. Boca Raton, Florida: Lewis, 283p.
- Myers, J.S. and Miller, R.L., 2005. Optical airborne remote sensing. In: Miller, R.L.; Del Castillo, R.E., and McKee, B.A. (eds.), *Remote Sensing of Coastal Aquatic Environments*. Dordrecht, The Netherlands: Springer, pp. 51–67.
- Narumalani, S.; Zhou, Y., and Jensen, J.R., 1997. Application of remote sensing and geographic information systems to the delineation and analysis of riparian buffer zones. *Aquatic Botany*, 58(3–4), 393–409.
- Novo, E.M.L.M.; Costa, M.P.F.; Mantovani, J.E., and Lima, I.B.T., 2002. Relationship between macrophyte stand variables and radar backscatter at L and C band, Tucuruí reservoir, Brasil. *International Journal of Remote Sensing*, 23, 1241–1260.
- Orbimage, 2003. *OrbView-3 Satellite and Ground Systems Specifications*. Dulles, Virginia: Orbimage, 2p.
- Owers, K.A.; Albanese, B., and Litts, T., 2012. Using aerial photography to estimate riparian zone impacts in a rapidly developing river corridor. *Environmental Management*, 49(3), 543–552.
- Ozesmi, S.L. and Bauer, M.E., 2002. Satellite remote sensing of wetlands. *Wetland Ecology and Management*, 10, 381–402.
- Papes, M.; Tupayachi, R.; Martinez, P.; Peterson, A.T., and Powell, G.V.N., 2010. Using hyperspectral satellite imagery for regional inventories: A test with tropical emergent trees in the Amazon basin. *Journal of Vegetation Science*, 21, 342–354.
- Parkinson, C.L., 2003. Aqua: An Earth-observing satellite mission to examine water and other climate variables. *IEEE Transactions on Geoscience and Remote Sensing*, 41, 173–183.
- Pengra, B.W.; Johnston, C.A., and Loveland, T.R., 2007. Mapping an invasive plant, *Phragmites australis*, in coastal wetlands using the EO-1 Hyperion hyperspectral sensor. *Remote Sensing of Environment*, 108, 74–81.
- Phillips, J.D., 1994. Wetland buffers and runoff hydrology. In: Mulamootil, G.; Warner, B.G., and McBean, E.A. (eds.), *Wetlands: Environmental Gradients, Boundaries and Buffers*. Boca Raton, Florida: CRC, pp. 207–220.
- Phinn, S.R.; Stow, D.A., and Zedler, J.B., 1996. Monitoring wetland habitat restoration in Southern California using airborne multi-spectral video data. *Restoration Ecology*, 4, 412–422.
- Purkis, S. and Klemas, V., 2011. *Remote Sensing and Global Environmental Change*. Oxford, United Kingdom: Wiley-Blackwell, 384p.
- Rosenqvist, A.; Finlayson, C.M.; Lowry, J., and Taylor, D., 2007. The potential of long-wavelength satellite-borne radar to support implementation of the Ramsar Wetland Convention. *Aquatic Conservation: Marine and Freshwater Ecosystems*, 17, 229–244.
- Rosso, P.H.; Ustin, S.L., and Hastings, A., 2005. Mapping marshland vegetation of San Francisco Bay, California, using hyperspectral data. *International Journal of Remote Sensing*, 26, 5169–5191.
- Rundquist, D.; Narumalani, S., and Narayanan, R., 2001. A review of wetlands remote sensing and defining new considerations. *Remote Sensing Reviews*, 20(3), 207–226.
- Schmidt, K.S. and Skidmore, K.A., 2003. Spectral discrimination of vegetation types in a coastal wetland. *Remote Sensing of Environment*, 85, 92–108.
- Schmidt, K.S.; Skidmore, A.K.; Kloosterman, E.H.; Van Oosten, H.; Kumar, L., and Janssen, J.A.M., 2004. Mapping coastal vegetation using an expert system and hyperspectral imagery. *Photogrammetric Engineering and Remote Sensing*, 70, 703–716.
- Schultz, R.C.; Isenhardt, T.M.; Simpkins, W.W. and Colletti, J.P., 2004. Riparian forest buffers in agroecosystems: Lessons learned from the Bear Creek watershed, central Iowa, USA. *Agroforestry Systems*, 61, 35–50.
- Seitzinger, S.P., 1994. Linkages between organic matter mineralization and denitrification in eight riparian wetlands. *Biogeochemistry*, 25, 19–39.
- Simard, M.; Fatoyinbo, L.E., and Pinto, N., 2010. Mangrove canopy 3D structure and ecosystem productivity using active remote sensing. In: Wang, J. (ed.), *Remote Sensing of Coastal Environment*. Boca Raton, Florida: CRC, pp. 61–78.

- Sinokrot, B.A. and Stefan, H.G., 1993. Stream temperature dynamics: Measurement and modeling. *Water Resources Research*, 29, 2299–2312.
- Space Imaging, 2003. *Ikonos Imagery Products and Product Guide*, Version 1.3. Thornton, Colorado: Space Imaging, 2p.
- Sweeney, B.W.; Both, T.L.; Jackson, J.K.; Kaplan, I.A.; Newbold, J.D.; Standley, L.J.; Hession, W.C.; Horwitz, R.I., and Wolman, M.G., 2004. Riparian deforestation, stream narrowing, and loss of stream ecosystem services. *Proceedings of the National Academy of Sciences of the USA*, 101(39), 14,132–14,137.
- Thomson, A.G.; Fuller, R.M.; Sparks, T.H.; Yates, M.G., and Eastwood, J.A., 1998. Ground and airborne radiometry over intertidal surfaces: Waveband selection for cover classification. *International Journal of Remote Sensing*, 19, 1189–1205.
- Tolner, E.W.; Barfield, B.J., and Hayes, J.C., 1982. Sedimentology of erect vegetal filters. *Proceedings of the Hydraulics Division, American Society of Civil Engineers*, 108, 1518–1531.
- Townsend, P.A., 2000. A quantitative fuzzy approach to assess mapped vegetation classifications for ecological applications. *Remote Sensing of Environment*, 72, 253–267.
- Townsend, P.A., 2002. Relationships between forest structure and the detection of flood inundation in forested wetlands using C-band SAR. *International Journal of Remote Sensing*, 23, 443–460.
- Vaiphasa, C.; Ongsomwang, S.; Vaiphasa, T., and Skidmore, A.K., 2005. Tropical mangrove species discrimination using hyperspectral data: A laboratory study. *Estuarine, Coastal and Shelf Science*, 65, 371–379.
- Valentine, V.J., 2002. Scrub–Shrub/Emergent Wetland Ecotone Migration along Delaware Tidal Rivers in Response to Relative Sea-Level Change, Natural Impacts, and Human Modifications. Ph.D. diss., Newark, Delaware: University of Delaware, 127p.
- Van der Peijl, M.J. and Verhoeven, J.T.A., 1999. A model of carbon, nitrogen and phosphorus dynamics and their interactions in river marginal wetlands. *Ecological Modeling*, 118, 95–130.
- Wang, Y., 2010. Remote sensing of coastal environments: An overview. In: Wang, J. (ed.), *Remote Sensing of Coastal Environments*. Boca Raton, Florida: CRC, pp. 1–24.
- Weller, D.E.; Jordan, T.E., and Correll, D.L., 1998. Heuristic models for material discharge from landscapes with riparian buffers. *Ecological Applications*, 8(4), 1156–1169.
- Welsch, D.J., 1991. *Riparian Forest Buffers*. Radnor, Pennsylvania: U.S. Department of Agriculture. Publication NA-PR-07-91, 24p.
- Wenger, S., 1999. A Review of the Scientific Literature on Riparian Buffer Width, Extent, and Vegetation. Athens, Georgia: School of Ecology, University of Georgia. <http://www.rivercenter.uga.edu/publications.htm> (accessed 3 January 2010).
- Xiang, W., 1993. A GIS for riparian water quality buffer generation. *International Journal of Geographic Information Systems*, 7, 57–70.
- Yang, J. and Artigas, F.J., 2010. Mapping salt marsh vegetation by integrating hyperspectral and LIDAR remote sensing. In: Wang, J. (ed.), *Remote Sensing of Coastal Environment*. Boca Raton, Florida: CRC, pp. 173–190.