



## **Ecological Factors Influencing Physical Soil Degradation in the Atacora Mountain Chain in Benin, West Africa**

Authors: Okou, Farris A. Y., Assogbadjo, Achille E., Bachmann, Yvonne, and Sinsin, Brice

Source: Mountain Research and Development, 34(2) : 157-166

Published By: International Mountain Society

URL: <https://doi.org/10.1659/MRD-JOURNAL-D-13-00030.1>

---

BioOne Complete ([complete.BioOne.org](https://complete.BioOne.org)) is a full-text database of 200 subscribed and open-access titles in the biological, ecological, and environmental sciences published by nonprofit societies, associations, museums, institutions, and presses.

Your use of this PDF, the BioOne Complete website, and all posted and associated content indicates your acceptance of BioOne's Terms of Use, available at [www.bioone.org/terms-of-use](https://www.bioone.org/terms-of-use).

Usage of BioOne Complete content is strictly limited to personal, educational, and non - commercial use. Commercial inquiries or rights and permissions requests should be directed to the individual publisher as copyright holder.

---

BioOne sees sustainable scholarly publishing as an inherently collaborative enterprise connecting authors, nonprofit publishers, academic institutions, research libraries, and research funders in the common goal of maximizing access to critical research.

# Ecological Factors Influencing Physical Soil Degradation in the Atacora Mountain Chain in Benin, West Africa

Farris A. Y. Okou<sup>1\*</sup>, Achille E. Assogbadjo<sup>1</sup>, Yvonne Bachmann<sup>2</sup>, and Brice Sinsin<sup>1</sup>

\* Corresponding author: farrisy@yahoo.fr

<sup>1</sup> Laboratory of Applied Ecology, Faculty of Agronomic Sciences, University of Abomey-Calavi, 01 BP 526, Cotonou, Benin

<sup>2</sup> Institute of Ecology, Evolution and Diversity, J. W. Goethe University, Max-von-Laue-Straße 13, 60438 Frankfurt am Main, Germany

Open access article: please credit the authors and the full source.



This study analyzed the ecological factors influencing soil degradation in the Atacora Mountains in northern Benin, which harbor two endemic species, *Thunbergia atacorensis* and *Ipomoea beninensis*.

Data were collected along line transects from plain to summit within 22 plots of 30 m × 30 m. Indicators of physical soil degradation (extent of organic layer, color of topsoil, compactness of soil, presence and extent of rills, and occurrence of sheet erosion) and environmental factors (canopy and ground cover, topography, occurrence of flooding, and slope) were assessed. Cluster

analysis identified 4 soil degradation classes: light, moderate, high, and extreme. Discriminant and multivariate variance analyses identified canopy and ground cover as the 2 main ecological drivers of soil degradation. Plant, litter, and stone cover were found to decrease as soil degradation increased. The parts of the Atacora Mountains with high elevation and steep slope were found to be less degraded than areas with low slopes, which are easily accessible for human activities. Policies to mitigate soil degradation should prioritize practices with low impact on vegetation cover and promote soil protection practices such as tree planting and mulching.

**Keywords:** Soil degradation; degradation classes; ecological factors; Atacora Mountains; Republic of Benin; West Africa.

**Peer-reviewed:** February 2014 **Accepted:** April 2014

## Introduction

Soil degradation, recognized as a major process of land degradation (Stocking and Murnaghan 2001), can be physical, chemical, or biological and includes erosion and loss of fertility (Snakin et al 1996). Erosive processes transform soils into a mosaic of land surfaces (Chartier and Rostagno 2006). According to Pickup (1985), land surfaces represent different states of soil loss or soil gain, each characterized by particular vegetation types and soil characteristics. Soil degradation is a worldwide threat that is increasing in extent and severity (Adams and Eswaran 2000; Bai et al 2008; Kapalanga 2008). It is seen as the outcome of the complex interplay of both natural processes and socioeconomic factors (particularly land use) (Blaikie and Brookfield 1987; Stocking and Murnaghan 2001; Reynolds and Stafford Smith 2002; Boardmana et al 2003; Geist and Lambin 2004; Foley et al 2005; Reynolds et al 2007; Haines-Young 2009).

The severity of soil degradation depends on the sensitivity of individual elements in the ecosystem to anthropogenic and natural disturbances. The design of decision support systems to reverse land and soil degradation requires, above all, sound assessments of these systemic interdependencies (Kapalanga 2008).

Efforts must be based on a profound understanding of soil degradation—its causes, risks, impacts, and severity, their relationships with socioeconomic factors, and the key ecological factors affected. However, soil degradation processes are difficult to grasp in their totality. One of the most common assessment methods at the field or farm level is the use of indicators of soil degradation combined with a classification of soils based on their erodibility (Stocking and Murnaghan 2001, Kapalanga 2008). Comparisons of soil classes can provide a good understanding of ongoing processes and the factors influencing them (Berry et al 2003; Majule 2003; De Bie 2005).

An important mountain chain in West Africa extends from Ghana (Akwakpim Hills) to Togo (Mount Togo) and Republic of Benin (Atacora Mountains). In Benin, the chain reaches altitudes of 400–600 m; it is of a high socioeconomic importance (Avohou and Sinsin 2009) and ecological specificity, with the occurrence of 2 endemic Beninese plant species, *Thunbergia atacorensis* (Acanthaceae) and *Ipomoea beninensis* (Convolvulaceae) (Akoègninou and Lisowski 2004). The Beninese part of the Atacora mountain chain is undergoing soil degradation (Adegbidi et al 1999; Mulder 2000). Soil nutrients are lost due to, among other causes, the hilly relief, with steep slopes.

There have been few studies of land degradation in the Atacora Mountains. Saïdou et al (2004) investigated farmers' perceptions of the causes and consequences of land degradation at the field level and found that farmers assessed the soil fertility on the basis of dicotyledonous weeds, soil texture, soil color, and fauna (earthworm casts). Tente and Sinsin (2005) found that the loss of soil in the Atacora Mountains is more severe upslope than downslope and greater in ploughed areas. However, much remains to be learned about soil degradation processes in the Atacora mountain chain, and this knowledge is needed for effective monitoring and management. The aim of this study is to contribute to that knowledge by (1) analyzing physical soil degradation processes in the Atacora Mountains using indicators and a classification approach and (2) highlighting the main ecological factors influencing these processes.

## Study area

The study area covered the district of Toucountouna (10°21'36"N to 10°44'34.8"N; 1°12'36"E to 1°38'27.6"E). Four main ethnic groups dwell in the Atacora range: the Bétamaribé, Wama, Natemba, and Gourmantsé (Wala 2005). The four ethnic groups mingle, and all of them carry out activities that both affect and depend on the mountains, primarily farming and animal breeding, but also fishing, hunting, and small industry including stone crushing (INSAE 2002).

The Atacora mountain chain (Figure 1) is located in the Sudanian West African climate zone, which is characterized by a mean annual precipitation range of 800–1000 mm and two seasons (a dry season from November to March and a rainy season from April to October). However, the plains areas surrounding the mountain chain, under the orographic influence of mountains, show a higher annual rainfall of up to 1300 mm per year instead of the range of 800–1000 mm observed in the common Sudanian zone (Houndenou and Hernandez 1998; Heinrich and Moldenhauer 2002). Average temperature and relative humidity during the last 35 years have ranged between 25.3°C and 30.5°C and between 26.8% (dry season) and 80.5% (wet season), respectively. The major characteristic of the topography is steep (30–60%) slopes, but there are also hilltops, plateaus, and valleys. In general, hills face east or west. East-facing hillsides are mainly exposed to the Harmattan, a dry northeast wind from the Sahara Desert blowing during the dry season (Jenik and Hall 1966). West-facing hillsides are exposed to a moist monsoon from the Atlantic Ocean (Le Barbe et al 2002).

Rocky and shallow soils are dominant throughout the mountain chain. Sandy and clayey soils with moderate stone content are found in seasonally wet or inundated valleys. The combination of ecological factors explains the diversity of vegetation patterns, consisting of shrubs,

trees, and woodland savannas dominated by *Isoblerlinia doka*, *Daniellia oliveri*, *Vitex* spp., *Terminalia glaucescens*, and *Parinari polyandra* (Sieglstetter and Wittig 2002; Tente and Sinsin 2002; Wala 2005).

## Material and methods

### Data collection

Two sampling sites were identified, with the help of extension service agents and local residents. The sites met the following criteria: ferricrete areas close to hillsides, and accessibility during the rainy season. Transect lines for data collection were identified based on local knowledge about soil degradation. Within each site, transect lines were established from plain to summit, aiming to cover the ecological diversity of the sites. At each topographical position (plain, downslope, hillside, and summit) along the transect line, we installed 5 or 6 nested sample plots on the grass, shrub, and tree savanna encountered (30 m × 30 m for the woody layer and 10 m × 10 m for the herbaceous layer). The vegetation structure (number of layers, their canopy, and basal cover) and the ground cover (litter and stone cover) were estimated using Braun-Blanquet's (1932) cover/abundance scale: + = rare (less than 1%), 1 = 1–5%, 2 = 5–25%, 3 = 25–50%, 4 = 50–75%, and 5 = 75–100%. Canopy cover is the area of ground covered by the vertical projection of the outermost perimeter of the natural spread of foliage of plants; basal cover is the area of ground surface occupied by the basal portion of the plants; ground cover is the cover litter, rocks, and gravel on a site. In total, 22 plots were sampled. Heights of herbaceous and shrub layers were assessed with a decimeter, and we used a clinometer for the height of the tree layer. Visual indicators of erosion were estimated and coded as follows:

- *Extent of organic layer* was assessed by vertically dropping a metal rod on the ground and noting what kind of soil layer (organic layer or other) it touched (Daget and Poissonnet 1971). The rod was dropped every meter in 8 directions, until a distance of 15 m (for 4 half-median directions) and 21 m (for 4 half-diagonal directions) from the center of the plot was reached (Figure 2).
- *Color of topsoil layer* was assessed visually and coded as 1 = red (which indicates a mineral layer of soil) or 2 = black (which indicates an organic layer of soil).
- *Compactness of topsoil* was assessed visually and coded as follows: 1 = loose, 2 = compact, 3 = very compact, and 4 = hard.
- *Sheet erosion* was assessed visually based on the presence of sand sedimentation and coded as 1 = not visible or 2 = visible.
- *Presence and extent of rills* were visually assessed and coded using the Braun-Blanquet (1932) cover/abundance scale as described above.

**FIGURE 1** Extent of the Atacora mountain chain in Benin and location of the sampling plots in the district of Toucountouna. (Map by authors)

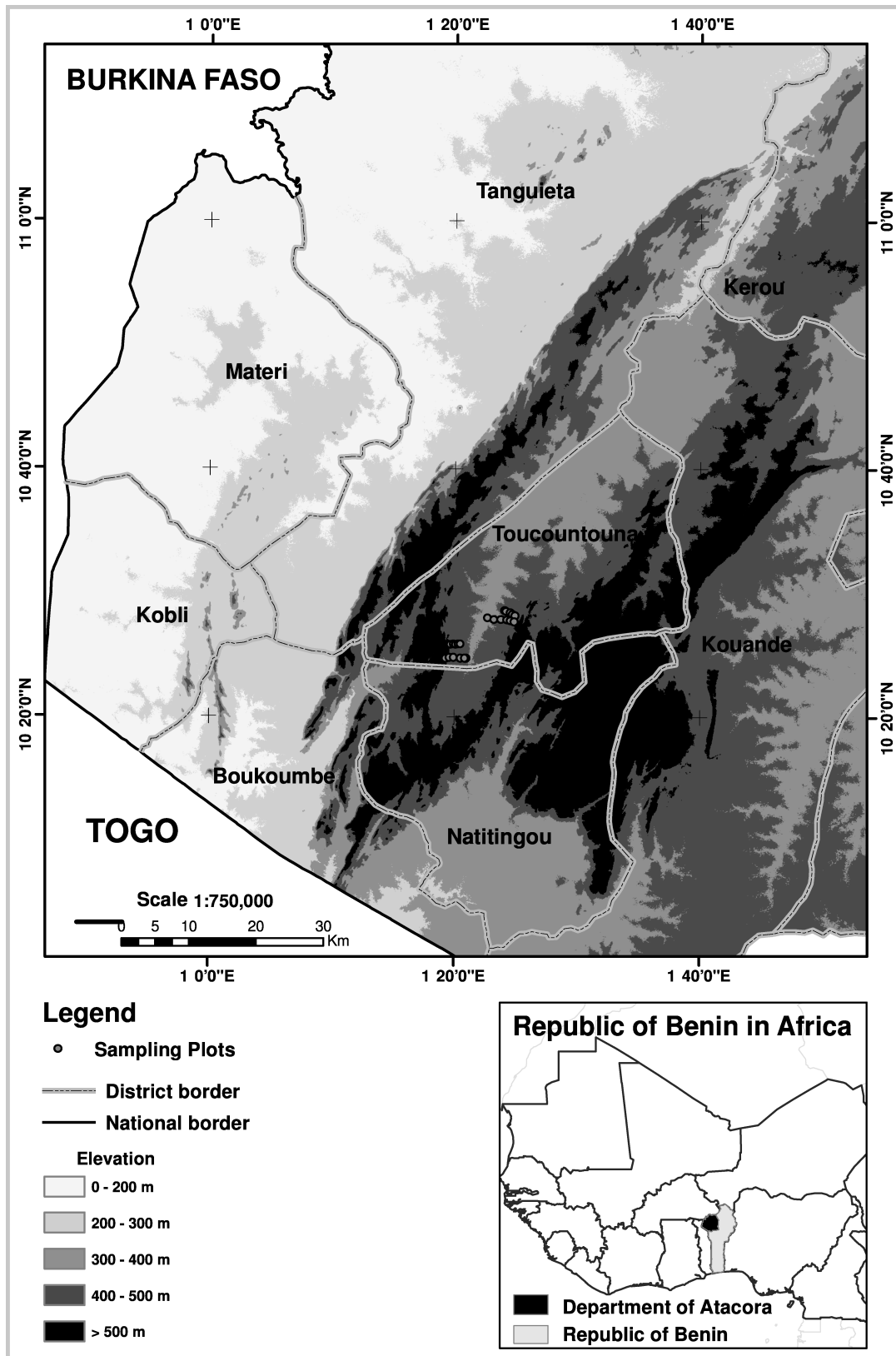
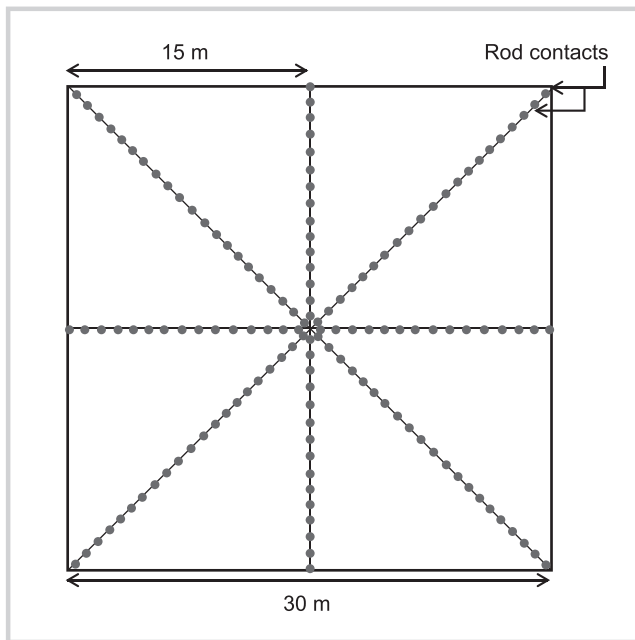

FIGURE 2 Sampling pattern for assessing the extent of the organic layer.



Ecological factors were assessed and coded as follows:

- *Topography* was assessed visually and coded as 1 = valley, 2 = plain, 3 = downslope, 4 = hillside, and 5 = plateau or summit.
- *Flooding* during the rainy season was assessed visually and based on local knowledge of the site status during dry season. It was coded as 1 = dry or 2 = flooded.
- *Slope angle* was assessed with a clinometer and recorded as number of degrees.
- *Canopy cover* and *ground cover* factors were derived from the height and cover of each vegetation layer estimated using Braun-Blanquet's (1932) cover/abundance scale.

**Data analysis**

Data on 5 indicators of erosion from 22 plots were submitted to a hierarchical cluster analysis with Ward's linkage method, using the software SAS 9.2 (SAS 2009) to produce clusters of plots based on the degree of soil degradation. Four clusters or soil degradation classes were defined.

Next, a discriminant analysis was carried out to determine whether and how ecological factors driving soil degradation varied along the gradient of degradation. The factors addressed in the analysis were topography, flooding, slope, canopy cover factor, and ground cover factor.

In order to identify the main ecological drivers of soil degradation, a multivariate analysis of variance (MANOVA) was performed. The average of measured ecological drivers was assessed according to the degradation stage (Azihou 2008; Azarnivand et al 2010). As variables, canopy cover factor, ground cover factor,

FIGURE 3 Canopy cover factor assessment results. The plain lines are the representation of Equation 1. They could be used for determining the canopy cover factor without computation of Equation 1. The dotted lines show the steps to be followed to determine the canopy cover factor based on EC and EH.

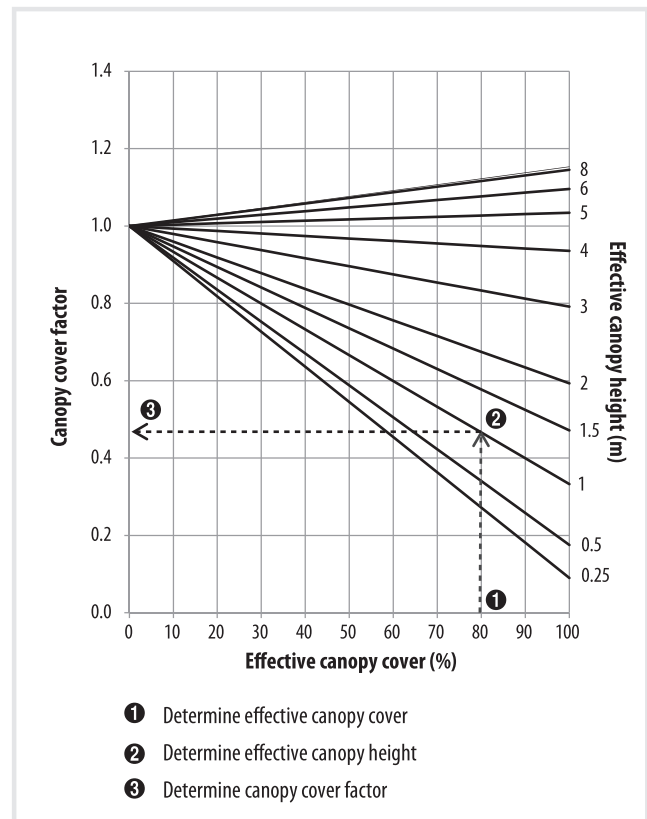

and slope were used (topography and flooding were not included in the analysis because they were qualitative variables).

The following sections explain how canopy cover factor and ground cover factor were computed. It is important to know that lower values of these factors indicate good canopy and ground cover, which are associated with lower soil loss (De Bie 2005).

*Canopy cover factor:* A canopy cover protects bare soil against erosion, but the foliage protection decreases in the direction of higher layers in the canopy (Wischmeier and Smith 1978; Kooiman 1987). Canopy cover factor quantifies the degree of protection offered by the canopy of a vegetation layer. Canopy cover factor is computed for each vegetation layer as

$$C_{Cf,x} = \langle 1 - \{ [1 - (37.13H - [4.02 \times EH^2]) + [0.146 \times EH^3]] / 100 \} \times EC \rangle, \tag{1}$$

where *EC* is the effective canopy cover (%), and *EH* is the effective canopy height (m) (Wischmeier and Smith 1978; Kooiman 1987; Palmer 1989; Figure 3).

The *EC* of the vegetation layer could be defined as the part of the remaining bare soil not covered by the canopy of vegetation layer below and that which is covered by the



**FIGURE 4** Determination of the effective canopy height of a tree. (Based on Jakubíková et al 2006)

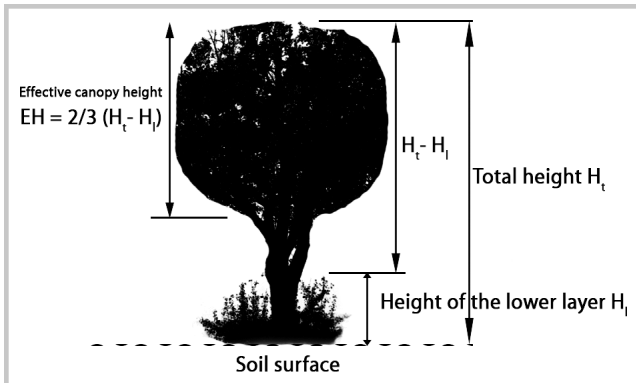

canopy of the vegetation layer concerned. Assuming a random distribution of basal cover and a nonrandom positioning of successive canopy layers, effective canopy cover was computed according to De Bie (2005) as:

1. Canopy cover of herbaceous layer (%) – basal cover (%)
2. Canopy cover of shrub layer (%)  $\times$  (1 – canopy cover of herbaceous layer [%])
3. Canopy cover of tree layer  $\times$  (1 – canopy cover of shrub layer [%])  $\times$  (1 – canopy cover of herbaceous layer [%]).

$EH$  could be defined as the average distance traveled by a raindrop from intercept by a plant before falling from this plant (De Bie 2005; Jakubíková et al 2006; Figure 4). It was computed as

$$EH = 2/3(H_t - H_l), \quad (2)$$

where  $H_t$  = total height, and  $H_l$  = height of the lower layer.

The canopy cover factor of one plot ( $C_{Cf}$ ) was computed by summing all layer-specific  $C_{Cf,x}$  as follows:  $(C_{Cf,1} + C_{Cf,2} + \dots + C_{Cf,X}) - (X - 1)$ , where  $X$  is the number of layers.

**Ground cover factor:** A high ground cover fraction (litter, basal cover, and stones) provides a protection against eroding rainfall and reduces runoff velocity while increasing infiltration (Wischmeier and Smith 1978). As shown in Figure 5, canopy cover factor decreases sharply as the ground cover increases. Ground cover factor ( $C_{Gf}$ ) values were computed for each plot according to the ground surface roughness as

$$C_{Gf} = [\exp^{- (b \times \text{ground cover}(\%))}], \quad (3)$$

where  $b$  is ground surface roughness, with a value of 0.05 recorded for rough field surfaces and 0.04 for smooth field surfaces (De Bie 2005). Ground cover percentage was computed as the sum of the percentages of litter, basal cover, and stones (De Bie 2005).

**FIGURE 5** Ground cover factor assessment results ( $b$  is ground surface roughness). The plain lines are the representation of Equation 3. They could be used for determining the ground cover factor without computation of Equation 3. The dotted lines show the steps to be followed to determine the ground cover factor based on the ground cover value.

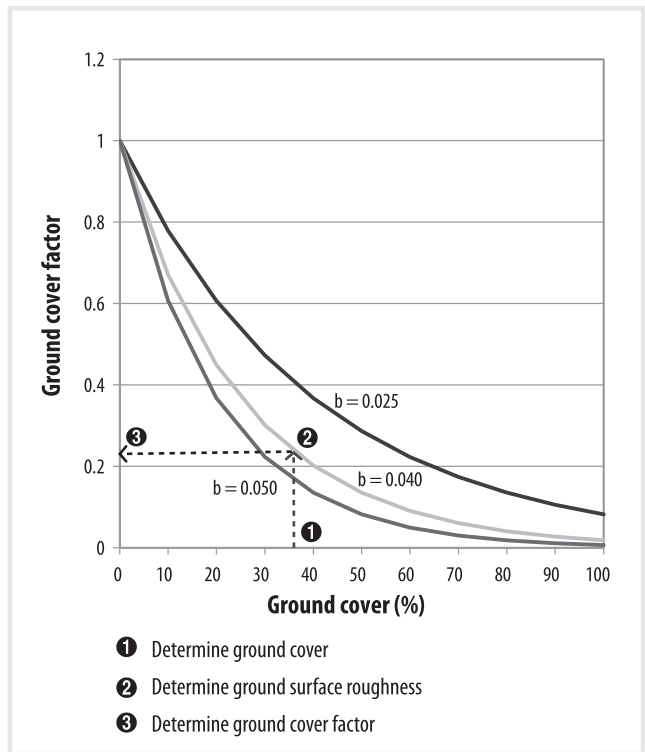

## Results

### Soil degradation classes

Cluster analysis of the 22 study plots, based on the severity of the erosion indicators, resulted in 4 clusters. An  $R$ -squared value of 96.8% was sufficient to obtain distinct clusters.

Cluster 1 was composed of 10 plots. They were characterized by a low level of soil compaction. Soil compaction limits water infiltration (few rills, no visible sheet erosion). On the topsoils of these plots, a black organic layer covered the entire surface; no reddish soils were observed. Based on these characteristics, these soils were characterized as having a light degree of erosion (to allow for the possibility of other types of physical soil degradation not observed during this study).

Cluster 2 contained 6 plots showing a great disturbance of the soil structure. The topsoil of these plots was ferricrete, rich in iron, and hard (Duchaufour 1952). The organic layer remained only on small patches (around 40% of rod contacts). Exposure of red soils was obvious. The presence of this ferricrete layer reduced the depth to which roots could grow. The thickness of the organic layer rarely exceeded 10 cm. There was no visible evidence of sheet erosion, and the mean rill cover was very low (0.5%) because of the high level of compaction. Due to the degree of surface sealing, the level of degradation assigned to this cluster of plots was extreme.

**TABLE 1** Erosion indicator values for the 4 plot clusters.

Clusters Erosion indicator	Cluster 1		Cluster 2		Cluster 3		Cluster 4	
	Mean	SD	Mean	SD	Mean	SD	Mean	SD
Extent of organic layer (%)	100.00	0	40.42	10.6	48.89	2.93	23.61	10.48
Presence of rills (% of area)	1.95	4.59	0.50	0	7.00	6.92	45.83	14.43
Color of topsoil	Black		Red		Red		Red	
Compactness of soil	Loose		Hard		Compact		Very compact	
Occurrence of sheet erosion	Not visible		Not visible		Visible		Visible	

Clusters 3 and 4 contained 3 plots each. The plots of cluster 3 were characterized by compact red soils, with a thin clay crust on the surface. Sheet erosion occurred on these soils, and rills covered on average 7% of the surface. Organic layers remained as thin patches (around 48% of rod contacts). The soils of cluster 4 were red and very compact. They looked like ferricrete but remained friable. Sheet erosion occurred here too. Rills covered a larger surface than on the other soils (around 45%), whereas the thin patches (never more than 5 cm thick) of organic layer were less extended (only 23% of rod contacts). The degree of degradation of cluster 3 was considered moderate, and that of cluster 4 was high.

Table 1 summarizes the erosion indicator values for each plot cluster.

### Ecological drivers of soil degradation

The main result of discriminant analysis was the projection of soil degradation classes in the canonical system axes based on ecological factors. Discriminant analysis summarizes all the information relative to the ecological drivers of degradation on many axes. In our case, the first 2 axes were significant and explained 97.12% of the initial information relative to the ecological drivers of degradation for each plot. Correlation between ecological drivers and axes 1 and 2 (Table 2) showed that the canopy cover (0.87) and the ground cover (0.99) were highly positively correlated with the first axis. Slope (−0.90) and topography (−0.93) were highly negatively correlated with the first axis. The only

**TABLE 2** Correlation between ecological factors and the 2 axes.

	Axis 1	Axis 2
Canopy cover factor	0.87	−0.14
Ground cover factor	0.99	0.02
Slope angle (%)	−0.90	−0.05
Topography	−0.93	0.26
Flooding during rainy season	0.65	0.75

occurrence of flooding was positively correlated with the second axis (0.75). In other words, axis 1 corresponded to the axis of high values of canopy and ground cover factors, low slope values, and low elevation values. Axis 2 represented the gradient of occurrence of flooding.

Extremely, highly, and moderately degraded soils were highly positively correlated with axis 1, while lightly degraded soils were highly negatively correlated with the same axis (Figure 6). Information on axis 1 indicated that extremely, highly, and moderately degraded soils were found on low slopes at low elevations. They were characterized by high values for  $C_{CF}$  and  $C_{GF}$ , which correspond to poor soil protection and high soil loss. Lightly degraded soils were found on steep slopes at high elevations. They were characterized by dense canopy cover and extensive ground cover.

Extremely degraded soils were highly positively correlated with axis 2. However, highly, moderately, and lightly degraded soils were negatively correlated with axis 2. Based on the ecological factors explained by the axis 2, we concluded that extremely degraded soils were often flooded during the rainy season, while lightly, highly, and moderately degraded soils were not.

Table 3 summarizes the ecological characteristics of the 4 degradation classes represented by the plot clusters. An analysis of variance was conducted between the mean values of some studied factors to find the reason for the differences in severity of soil degradation. The results provided by an *F*-test were significant ( $p < 0.01$ ) for all of the studied factors except slope. Canopy cover and ground cover factors were the 2 main ecological drivers of soil degradation.

### Discussion

This study identified 4 soil degradation classes in the Atacora mountain chain in northern Benin. They represent the different steps of forest soil degradation identified by Duchaufour (1952). According to Duchaufour, 2 factors—organic layer removal due to erosion, and hardening and desiccation due to solar radiation—explain all of the differences observed along

**FIGURE 6** Projection of soil degradation classes in the system axes based on ecological factors.

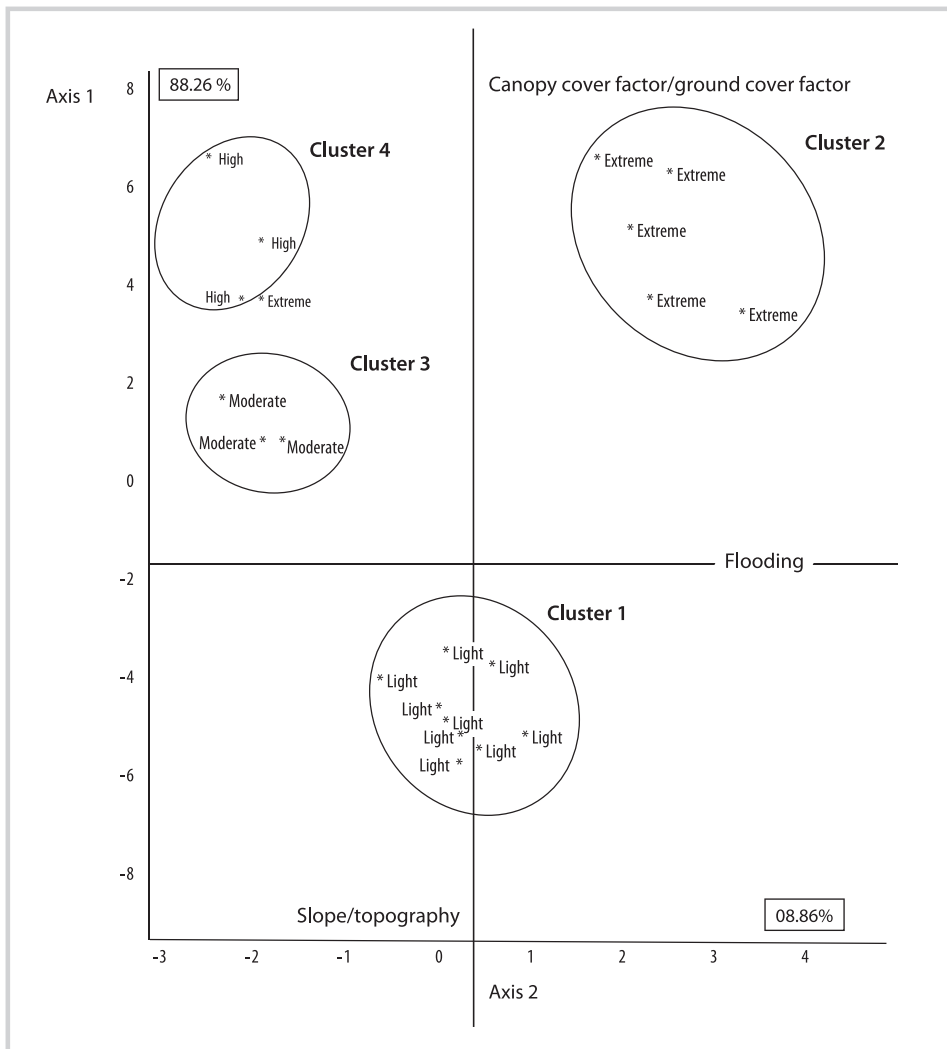

the gradient of tropical forest soil degradation. The 4 soil types identified were:

1. Lightly degraded soils: These are used as control plots for the observation of degradation processes because they present no obvious signs of soil degradation.
2. Moderately degraded soils: These appear when erosion, due to anthropogenic and ecological drivers, removes the organic layer, exposing the red layer. This layer is more compact and often forms a thin layer of curled plates called still depositional crust (Valentin and Bresson 1992).
3. Highly degraded soils or lateritic carapace: These occur when the red layer is hardened by desiccation. Great variations in temperature (17.4–37.1°C) and relative humidity (23–82%) in the study area facilitate the desiccation process.
4. A hard surface called ferricrete occurs when iron and aluminum oxides are dissolved during the rainy season

and migrate to the surface during the dry season (Duchaufour 1952; Bockheim and Gennadiyev 2009; Yuangen et al 2009). Compaction and surface sealing reduce infiltration and hydraulic conductivity, which increases surface water runoff (Frisby and Pfof 1993; Horton et al 1994; Radcliffe and Rasmussen 2000) and lengthens runoff periods (Hinckley et al 1983). The presence of water on extremely degraded soils during the rainy season can be explained by soil surface sealing. According to Bilong et al (1992), the erosive force of water could break up ferricrete into loose soil and then facilitate regeneration/reversal of the soil degradation process and recolonization by vegetation.

This study often found lightly degraded soils at high elevations with high slope angles. Similar results were found by Majule (2003) on the slopes of Mount Kilimanjaro, where soils in the lower zones were more



**TABLE 3** Ecological characteristics of the 4 degradation classes represented by the plot clusters.

Ecological factors	Degree of degradation									
	Light		Moderate		High		Extreme		F value	
	Mean	SD	Mean	SD	Mean	SD	Mean	SD		
Canopy cover factor	0.49	0.09	0.51	0.03	0.72	0.09	0.61	0.10	8.98	***
Ground cover factor	0.09	0.05	0.45	0.03	0.73	0.09	0.71	0.08	142.02	***
Slope angle (%)	3.85	2.50	0.80	0.29	2	0	0.75	0.27	4.96	ns
Topography	Plain, downslope, hillside, plateau, or summit		Valley or plain		Valley or plain		Plain		–	
Flooding during rainy season	Dry		Dry		Dry		Dry or flooded		–	

\*\*\*  $P \leq 0.001$ ; ns = no significant difference.

degraded (in physical and chemical terms) than soils in the middle and upper zones. This is an interesting result, as slope and elevation have also been recognized as increasing runoff velocity and therefore posing a greater erosion risk (Stocking and Murnaghan 2001; Saïdou et al 2004; Tente and Sinsin 2005; Inkpen and Stephenson 2006). Bonan (2002) and Molinar et al (2001), on the other hand, found that slope can act as a buffer, depending on aspect and initial stability of the soil. The presence of an organic layer rich in humus improves the soil structure and enhances the ability of the soil to hold moisture (Pidwirny and Jones 2010), and the lightly degraded soils of the study area are characterized by extensive coverage of organic layer. This explains the low level of degradation of these areas despite the fact that they are found at high elevations with high slope angles.

The increase of canopy and ground cover factors indicates the decrease in plant, litter, and stone cover as soil degradation worsens. Chapman (1948) established that vegetation canopies change the drop size and distribution of rain and that splash detachment under dense canopy is different from that under sparse canopy. Plant, litter, and stone cover protect the soil from raindrop impact. Splash tends to slow the movement of surface runoff and increase the infiltration rate and water-holding capacity of the soil (Molinar et al 2001; Bonan 2002). According to Bonan (2002), the erosion factor used to estimate total erosion losses in forests drops from 0.36 in soil with no litter cover to 0.003 with 100% litter cover. Chartier and Rostagno (2006) found that the rate of soil

erosion increased in northeastern Patagonian rangelands when plant and litter cover decreased. They identified 90% plant and litter cover as a site conservation/soil erosion threshold. We found that in the Atacora Mountains,  $C_{CF}$  and  $C_{GF}$  values above 0.5 indicated degraded soils or soils with high risk of erosion. Plant and litter also reduce soil evapotranspiration rates and reduce soil insolation (Molinar et al 2001; Kohutiar 2008).

We examined only ecological drivers because they are the key elements of an environment threatened by anthropogenic activities and other natural processes that lead to soil degradation. The identification of the most sensitive ecological factors will help decision makers to identify activities that have the greatest impact on these factors, thus contributing most to soil degradation. For instance, we found that plant, litter, and stone cover, if removed, are main ecological drivers of soil degradation processes. Activities such as shifting cultivation, overgrazing, and lopping of trees for fodder during the dry season, which remove the vegetation or vegetation cover and leave the soil bare, are threatening activities. Moreover, the local population should be trained to identify the different soil degradation classes and their characteristics in order to enhance their capacity to monitor soil degradation closely on their own.

Elevation and slope angle can also be seen as protecting soil because the higher and steeper the site, the more difficult it is for human beings to reach it and disturb it by their activities. Nevertheless, the

protection of steep hillsides and summits should be prioritized in management policies by tree planting and other management practices based on local knowledge.

## Conclusion

Physical soil degradation processes in the Atacora Mountains are very complex. This study examined various indicators of land degradation at the field level in northern Benin and found that:

- Soils of the Atacora mountain chain can be classified in 4 soil degradation categories (light, moderate, high, and extreme).

- Soils at high elevations with high slope angles were less degraded than those in lower zones.
- Plant, litter, and stone cover are the main ecological factors affecting soil degradation; they protect the soil, and their decrease leads to an increase in degradation.

For management purposes, plant, litter, and stone cover are indicators that could be used for monitoring of land degradation. Policies to mitigate soil degradation have to prioritize practices with low impact on vegetation cover and promote soil protection practices such as tree planting and mulching. Large-scale studies integrating remote-sensing data and geographic information systems are needed to investigate in detail the erosion risk status of the entire mountain chain.

## ACKNOWLEDGMENTS

The authors are indebted to the UNDESERT project (EU FP7 243906) "Understanding and Combating Desertification to Mitigate Its Impact on Ecosystem Services," funded by the European Commission, Directorate General for Research and Innovation, Environment Program, for financial

support. Our acknowledgment also goes to Amanda Morgan, Anne Zimmermann, Belarmain Fandohan, Romain Glèlè Kakai, and two anonymous reviewers, whose useful comments helped improve the quality of this document.

## REFERENCES

- Adams CR, Eswaran H, editors.** 2000. *Global Land Resources in the Context of Food and Environmental Security*. New Delhi, India: Soil Conservation Society of India.
- Adegbidi A, Burger K, Gandonou E, Mulder I.** 1999. *Farmers' Perceptions and Sustainable Land Use in the Atacora, Benin*. CREED Working Paper 22. London, United Kingdom: International Institute for Environment and Development.
- Akoègninou A, Lisowski S.** 2004. *Notulae florae beninensis 2. Un ipomoea (Convolvulaceae) nouveau et un thunbergia (Acanthaceae) nouveau du Bénin. Systematics and Geography of Plants* 74(2):337–340.
- Avohou HT, Sinsin B.** 2009. The effects of topographic factors on aboveground biomass production of grasslands in the Atacora Mountains in northwestern Benin. *Mountain Research and Development* 29(3):250–254. <http://doi.org/10.1659/mrd.00028>.
- Azarnivand H, Jafari HJ, Nikoo S, Chahouki MaZ, Malekian A.** 2010. Study of effective ecological factors on distribution of vegetation types (case study: southern margin of Haj Aliqholi Kavir, Damghan). *Desert* 15:1–4.
- Azihou FA.** 2008. *Ecological Factors Associated with the Spatial Isolation of Individual Trees of the Gregarious Species Isoberlinia doka Craib and Stapf in Benin*. Abomey-Calavi, Benin: University of Abomey-Calavi, Department of Natural Resources Management, Faculty of Agronomic Sciences.
- Bai ZG, Dent DL, Olsson L, Schaepman ME.** 2008. Proxy global assessment of land degradation. *Soil Use and Management* 24(3):223–234. <http://doi.org/10.1111/j.1475-2743.2008.00169.x>.
- Berry L, Olson J, Campbell D.** 2003. *Assessing the Extent, Cost and Impact of Land Degradation at the National Level: Findings and Lessons Learned from Seven Pilot Case Studies*. Rome, Italy: Global Mechanism of the United Nations Convention to Combat Desertification.
- Bilong P, Eno Belinga S, Volkoff B.** 1992. *Iron Crusted Landscape Evolution and Soil in Central African Rain Forest. Position of the Mottled Clay Soils*. Paris, France: Gauthier-Villars.
- Blaikie P, Brookfield H.** 1987. *Land Degradation and Society*. New York: Routledge Kegan & Paul.
- Boardman J, Poesen J, Evans R.** 2003. Socio-economic factors in soil erosion and conservation. *Environmental Science & Policy* 6:1–6.
- Bockheim JG, Gennadiyev AN.** 2009. The value of controlled experiments in studying soil-forming processes: A review. *Geoderma* 152(3–4):208–217. <http://doi.org/10.1016/j.geoderma.2009.06.019>.
- Bonan G.** 2002. *Ecological Climatology*. Cambridge, United Kingdom: Cambridge University Press.
- Braun-Blanquet J.** 1932. *Plant Sociology. The Study of Plant Communities*. New York: McGraw-Hill.
- Chapman G.** 1948. Size of rain drops and their striking force at the soil surface in a red pine plantation. *Eos, Transactions of the American Geophysical Union* 29:664–670.
- Chartier MP, Rostagno CM.** 2006. Soil erosion thresholds and alternative states in northeastern Patagonian rangelands. *Rangeland Ecology Management* 59(6):616–624. <http://doi.org/10.2111/06-009r.1>.
- Daget P, Poissonnet J.** 1971. Une méthode d'analyse phytosociologique des prairies. *Annales Agronomiques* 22:5–41.
- De Bie CAJM.** 2005. Assessment of soil erosion indicators for maize-based agro-ecosystems in Kenya. *Catena (Giessen)* 59(3):231–251.
- Duchaufour P.** 1952. La dégradation des sols forestiers en Côte d'Ivoire. *Revue Forestière Française* 12:789–797.
- Foley JA, Defries R, Asner GP, Barford C, Bonan G, Carpenter SR, Chapin FS, Coe MT, Daily GC, Gibbs HK, Helkowski JH, Holloway T, Howard EA, Kucharik CJ, Monfreda C, et al.** 2005. Global consequences of land use. *Science* 309:570–574.
- Frisby J, Pfost D.** 1993. *Soil Compaction: The Silent Thief*. Columbia, MO: University of Missouri–Columbia Extension.
- Geist HJ, Lambin EF.** 2004. Dynamic causal patterns of desertification. *BioScience* 54:817–829.
- Haines-Young R.** 2009. Land use and biodiversity relationships. *Land Use Policy* 26:178–186.
- Heinrich J, Moldenhauer K-M.** 2002. Climatic and anthropogenic induced landscape degradations of West African dry savanna environments during the later Holocene. *Quaternary International* 93–94:127–137.
- Hinckley BS, Iverson RM, Hallett B.** 1983. Accelerated water erosion in off-road vehicle use areas. In: Webb RH, Howard GW, editors. *Environmental Effects of Off-Road Vehicles, Impacts and Management in Arid Regions*. New York: Springer-Verlag, pp 81–94.
- Horton R, Ankeny MD, Allmaras RR.** 1994. Effects of compaction on soil hydraulic properties. In: Soane BD, Ouwerkerk CV, editors. *Soil Compaction in Crop Production*. Amsterdam, Netherlands: Elsevier, pp 141–165.
- Houdenou C, Hernandez K.** 1998. Modification of the rainy season in the Atacora Mountain region (1961–1990). A drought situation in northwestern Benin. *Sécheresse* 9(1):23–34.
- Inkpen RJ, Stephenson W.** 2006. Statistical analysis of the significance of site topography and erosion history on erosion rates on intertidal shore platforms, Kaikoura Peninsula, South Island, New Zealand. *Geomorphology* 81(1–2):18–28.
- INSAE [Institut National de la Statistique et de l'Analyse Economique du Bénin].** 2002. Troisième recensement général de la population et de l'habitat: Cahier des villages et quartiers de ville, Département de l'ATACORA. Cotonou, Bénin: INSAE.

- Jakubíková A, Janecek M, Tippl M.** 2006. Field determination of the specific input characteristics to calculate the value of C factor of time-variable crops for the revised universal soil loss equation (RUSLE). *Soil and Water Research* 1(1): 10–15.
- Jenik J, Hall JB.** 1966. The ecological effect of the Harmattan wind in the Djebobo massif (Togo Mountains, Ghana). *Journal of Ecology* 54(3):767–779.
- Kapalanga TS.** 2008. *A Review of Land Degradation Assessment Methods*. Report of the Land Restoration Training Programme. Reykjavik, Iceland: Soil Conservation Service of Iceland.
- Kohutiar J.** 2008. Soil sealing—A prospect of starvation (for soil bugs) and flooding (for us). Unpublished paper presented at the *Green Week Conference, 3–6 June*. Brussels, Belgium: European Commission. [http://ec.europa.eu/environment/archives/greenweek2008/sources/pres/3\\_4\\_Kohutiar.pdf](http://ec.europa.eu/environment/archives/greenweek2008/sources/pres/3_4_Kohutiar.pdf); accessed on 4 August 2012.
- Kooiman A.** 1987. *The Factor C: Relations between Landcover and Landuse, and Aspects of Soil Erosion, Specifically for the Upper Komering Catchment, South Sumatra, Indonesia*. New York, NY: International Typeface Corporation.
- Le Barbe L, Lebel T, Tapsoba D.** 2002. Rainfall variability in West Africa during the years 1950–90. *Journal of Climate* 15:187–202.
- Majule AE.** 2003. *Impacts of Land Use/Land Cover Changes on Soil Degradation and Biodiversity on the Slopes of Mount Kilimanjaro, Tanzania*. Land Use Change, Impacts and Dynamics Project Working Paper. Nairobi, Kenya: LUCID Project, International Livestock Research Institute.
- Molinar F, Galt D, Holechek J.** 2001. Managing for mulch. *Rangelands* 23(4):3–7.
- Mulder I.** 2000. *Soil Degradation in Benin: Farmers' Perceptions and Responses* [PhD dissertation]. Amsterdam, Netherlands: Tinbergen Institute, Vrije Universiteit Amsterdam.
- Palmer M.** 1989. *The Relationship between Land Cover, Land Use and Land Degradation*. Enschede, Netherlands: International Institute for Geo-Information Science and Earth Observation, University of Twente.
- Pickup G.** 1985. The erosion cell—A geomorphic approach to landscape classification in range assessment. *Australian Rangeland Journal* 7:114–121.
- Pidwirny M, Jones S.** 2010. Introduction to lithosphere—Introduction to soils. In: Pidwirny M, Jones S, editors. *Fundamentals of Physical Geography*. Okanagan, Canada: University of British Columbia, Okanagan, [www.physicalgeography.net/fundamentals/10t.html](http://www.physicalgeography.net/fundamentals/10t.html); accessed 4 August 2012.
- Radcliffe DE, Rasmussen TC.** 2000. Soil water movement. In: Sumner ME, editor. *Handbook of Soil Science*. Boca Raton, FL: CRC Press, pp 87–128.
- Reynolds JF, Maestre FT, Kemp PR, Stafford-Smith DM, Lambin E.** 2007. Natural and human dimensions of land degradation in drylands: Causes and consequences. In: Canadell JG, Pataki DE, Pitelka LF, editors. *Terrestrial Ecosystems in a Changing World*. Berlin and Heidelberg, Germany: Springer, pp 247–258.
- Reynolds JF, Stafford Smith DM.** 2002. *Global Desertification: Do Humans Create Deserts?* Berlin, Germany: Dahlem University Press.
- Saidou A, Kuyper TW, Kossou D, Tossou RC, Richards P.** 2004. Sustainable soil fertility management in Benin: Learning from farmers. *NJAS Wageningen Journal of Life Sciences* 52(3/4):349–369.
- SAS.** 2009. *SAS/STAT User's Guide*. Cary, NC: SAS Institute.
- Sieglstetter R, Wittig R.** 2002. L'utilisation des ligneux sauvages et son effet sur la végétation de la région D'atakora (Bénin nord-occidental). *Etudes de la Flore et de la Végétation du Burkina Faso et des Pays Avoisinants* 7:23–30.
- Snakin VV, Krechetov PP, Kuzovnikova TA, Alyabina I, Gurov AF, Stepichev AV.** 1996. The system of assessment of soil degradation. *Soil Technology* 8: 331–343.
- Stocking M, Mumaghan N.** 2001. *Handbook for the Field Assessment of Land Degradation*. Sterling, VA: Earthscan.
- Tente B, Sinsin B.** 2002. Diversité et structure des formations arborescentes du secteur perma-toucountouna dans la chaîne de l'Atacora (Bénin). *Etudes de la Flore et de la Végétation du Burkina Faso et des Pays Avoisinants* 6:31–42.
- Tente B, Sinsin B.** 2005. *Recherche sur les Facteurs de la Diversité Floristique des Versants du Massif de l'Atacora: Secteur Perma-Toucountouna (Bénin)* [PhD dissertation]. Abomey-Calavi, Benin: Université d'Abomey-Calavi, Ecole Pluridisciplinaire "Espaces, Cultures et Développement."
- Valentin C, Bresson LM.** 1992. Morphology, genesis and classification of surface crusts in loamy and sandy soils. *Geoderma* 55:225–245.
- Wala K.** 2005. *La Végétation de la Chaîne de l'Atacora au Bénin: Diversité Floristique, Phytosociologique et Impact Humain* [PhD dissertation]. Lomé, Togo: Université de Lomé, Faculté des Sciences.
- Wischmeier WH, Smith DD.** 1978. *Predicting Rainfall Erosion Losses—A Guide to Conservation Planning*. Agriculture Handbook 537. Washington, DC: US Department of Agriculture, Science and Education Administration.
- Yuangen Y, Shirong L, Zhisheng J.** 2009. Laterization and its control to gold occurrence in Laowanchang gold deposit, Guizhou Province, southwest China. *Journal of Geochemical Exploration* 100:67–74.