



Expression and Genomic Organization of A Medaka Fish Novel Membrane Form of Guanylyl Cyclase/Orphan Receptor

Authors: Yamagami, Sayaka, Xu, Shan Hua, Tsutsumi, Makiko, Hori, Hiroshi, and Suzuki, Norio

Source: Zoological Science, 20(5) : 591-606

Published By: Zoological Society of Japan

URL: <https://doi.org/10.2108/zsj.20.591>

BioOne Complete (complete.BioOne.org) is a full-text database of 200 subscribed and open-access titles in the biological, ecological, and environmental sciences published by nonprofit societies, associations, museums, institutions, and presses.

Your use of this PDF, the BioOne Complete website, and all posted and associated content indicates your acceptance of BioOne's Terms of Use, available at www.bioone.org/terms-of-use.

Usage of BioOne Complete content is strictly limited to personal, educational, and non - commercial use. Commercial inquiries or rights and permissions requests should be directed to the individual publisher as copyright holder.

BioOne sees sustainable scholarly publishing as an inherently collaborative enterprise connecting authors, nonprofit publishers, academic institutions, research libraries, and research funders in the common goal of maximizing access to critical research.

Expression and Genomic Organization of A Medaka Fish Novel Membrane Form of Guanylyl Cyclase/Orphan Receptor

Sayaka Yamagami¹, Shan Hua Xu¹, Makiko Tsutsumi²,
Hiroshi Hori² and Norio Suzuki^{1*}

¹*Division of Biological Sciences, Graduate School of Science, Hokkaido University,
Sapporo 060-0810, Japan*

²*Division of Biological Sciences, Graduate School of Science, Nagoya University,
Nagoya 464-8602, Japan*

ABSTRACT—A novel membrane guanylyl cyclase (membrane GC), OIGC8, was identified in the medaka fish *Oryzias latipes* by the isolation of full-length cDNA (4958 bp) and genomic DNA (14.3 kbp) clones. Phylogenetic analysis indicated that OIGC8 does not belong in any known vertebrate membrane GC subfamily. OIGC8 consists of an extracellular domain (214 residues), a transmembrane segment (19 residues), and an intracellular protein kinase-like domain (284 residues) and a cyclase catalytic domain (228 residues), although the extracellular domain is about half the length (around 450 residues) of other known vertebrate membrane GCs. OIGC8 transiently expressed in COS-7 cells exhibited only basal guanylyl cyclase activity. None of the known ligands (rat ANP, BNP, CNP, and C-ANF) and various medaka fish tissue extracts, which activated OIGC1, OIGC2, and OIGC7 differentially, stimulated basal activity, suggesting that OIGC8 is an orphan receptor. The *OIGC8* gene consists of 24 exons and exists as a single copy on the medaka fish genome. Northern blot hybridization showed that a 5 kb-*OIGC8* mRNA was expressed in the kidney and the testis at a high level and a 3.3 kb-*OIGC8* mRNA was expressed only in the brain. The RNase protection, RNA Ligase-Mediated Rapid Amplification of cDNA Ends (RLM-RACE), and reverse transcription-polymerase chain reaction (RT-PCR) analyses demonstrated that the 3.3 kb-*OIGC8* mRNA detected in the brain is transcribed from the second transcription initiation site, and contains an intron at the position prior to the catalytic domain, the translation product of which appears to be a protein lacking the cyclase catalytic domain.

Key words: guanylyl cyclase, cGMP, orphan receptor, natriuretic peptide, splicing

INTRODUCTION

Guanylyl cyclase (GC), an enzyme converting GTP to cGMP, is found in various cellular compartments of many organisms, in soluble and/or membrane-bound forms (Drewett and Garbers, 1994; Wedel and Garbers, 2001). Membrane GC contains a single transmembrane segment that divides the protein into approximately two halves of equal length; an extracellular domain and an intracellular domain are also present that consist of protein kinase-like and cyclase catalytic domains. To date, various membrane

GC isoforms have been identified in vertebrates and invertebrates through the isolation of a full-length cDNA clone. Some of these membrane GCs are cell-surface receptors for peptides such as natriuretic peptides and heat-stable enterotoxins, but the others remain presumed orphan receptors (Garbers and Lowe, 1994; Wedel and Garbers, 2001). Phylogenetic analyses of various membrane GCs from mammals and medaka fish have shown that vertebrates have three major subfamilies of membrane GCs: (i) a natriuretic peptide subfamily, (ii) an enterotoxin/guanylin receptor subfamily, and (iii) a sensory organ-specific GC subfamily (Kusakabe and Suzuki, 2000). Natriuretic peptides such as atrial natriuretic peptide (ANP), brain natriuretic peptide (BNP), and C-type natriuretic peptide (CNP) activate the receptor/membrane GCs (GC-A and GC-B) upon binding to the extracellular domain (Chang *et al.*, 1989; Chinkers *et al.*, 1989; Lowe *et al.*, 1989; Schulz *et al.*, 1989). The extracellular domain of GC-A or GC-B is similar to that

The nucleotide sequence data reported in this paper have been submitted to the DDBJ, EMBL, and GenBank nucleotide sequence databases, and is available under accession number AB054814 for genomic DNA of *OIGC8*.

* Corresponding author: Tel. +81-11-706-4908;

FAX. +81-11-706-4461.

E-mail: norio-s@sci.hokudai.ac.jp

of the NPR-C receptor (clearance factor), which contains an NP-binding domain and a short cytoplasmic tail and is not coupled to the activation of guanylyl cyclase (Füller *et al.*, 1988).

The kinase-like domain of membrane GCs appears necessary for the stimulation of guanylyl cyclase activity upon ANP-binding to the extracellular domain, since deletion of the kinase-like domain destroys the ability of ATP to activate the cyclase catalytic domain (Chinkers and Garbers, 1989). The cyclase catalytic domain of various sources of membrane GCs are identical to each other and similar to that of both the α_1 - and β_1 -subunits of soluble GC (Koesling *et al.*, 1988; Koesling, 1990; Nakane *et al.*, 1988) and adenylyl cyclase (Krupinski *et al.*, 1989). The protein kinase-like/cyclase catalytic domain arrangement is seen in all membrane GCs found in mammals, medaka fish, sea urchins, nematodes, *Drosophila*, and yeast (Chang *et al.*, 1989; Chinkers *et al.*, 1989; Kusakabe and Suzuki, 2000; Lowe *et al.*, 1989; Schulz *et al.*, 1989; Shimiz *et al.*, 1996; Suzuki *et al.*, 1999).

The medaka fish *Oryzias latipes* possesses all types of membrane GC isoforms that have been identified and characterized in mammals (Kusakabe and Suzuki, 2000). OIGC1 and OIGC2 and OIGC7 are medaka fish homologs of mammalian GC-A and GC-B, respectively (Takeda and Suzuki, 1999; Yamagami *et al.*, 2001), and OIGC6 is a medaka fish homolog of mammalian GC-C (Mantoku *et al.*, 1999). In addition to these isoforms, four membrane GCs (OIGC3, OIGC4, OIGC5, and OIGC-R2) have been identified in the sensory organs of medaka fish (Hisatomi *et al.*, 1999; Seimiya *et al.*, 1997). In mammals, three membrane GCs (GC-D, RetGC-1/GC-E, and RetGC-2/GC-F) have been identified in the sensory organs; GC-D is expressed in a subpopulation of rat olfactory sensory neurons (Fülle *et al.*, 1995), and two retina-specific membrane GCs (RetGC-1/GC-E and RetGC-2/GC-F) have been isolated and characterized from human retina (Lowe *et al.*, 1995; Shyjan *et al.*, 1992; Yang *et al.*, 1995). RetGC-1/GC-E and RetGC-2/GC-F are activated by the Ca^{2+} -binding proteins such as GCAP-1 and GCAP-2 by binding to the intracellular domains (Dizhoor *et al.*, 1994; Laura *et al.*, 1996). To date, no extracellular ligand has been identified for these sensory organ-specific membrane GCs, implicating that they remain presumed orphans (Garbers and Lowe, 1994).

Recently, a novel membrane GC (GC-G) was identified in rat jejunum and skeletal muscle and its molecular nature was characterized (Schulz *et al.*, 1998). The domain organization of GC-G is the same as that seen in known membrane GCs, and the Cys residues within the extracellular domain of GC-G are conserved. However, ligands for the other membrane GCs, such as natriuretic peptides or heat-stable enterotoxins, fail to stimulate GC-G. Furthermore, no specific ligand or intercellular activating protein for GC-G has been isolated to date. Therefore, GC-G appears to represent a cyclase-coupled orphan receptor.

It is known that fish (e.g., medaka fish, zebrafish, and

the Japanese pufferfish Fugu) contain more members in the same gene family than do mammals (Meyer and Scharl, 1999). For example, mammals have two natriuretic peptide receptor genes, *GC-A* and *GC-B*, whereas medaka fish contain three different natriuretic peptide receptor genes, *OIGC1*, *OIGC2*, and *OIGC7*. Moreover, medaka fish possess four different sensory organ-specific membrane GC genes, whereas mammals possess three of them. These findings may be explained by the hypothesis that an additional (third) entire genome duplication took place during the evolution of actinopterygian fish that other vertebrates did not undergo. This hypothesis might be extended to other membrane GCs, the subtypes of which have not yet been found in medaka fish. Recently, the second isoform of GC-C was cloned from the intestine of the European eel *Anguilla anguilla* (Comrie *et al.*, 2001). To understand the comprehensive system of signal transduction via cGMP in medaka fish, we examined whether medaka fish possess additional membrane GC genes. Amplification of cDNA fragments encoding GCs by reverse transcription-polymerase chain reaction (RT-PCR) using various medaka fish tissues, we found a membrane GC, *OIGC8*, which is structurally and biologically novel. Here, we report its enzymatic nature, genomic structure, tissue-specific expression pattern, and spliced variants.

MATERIALS AND METHODS

Animals and embryos

Mature adults of the orange-red variety of the medaka fish *O. latipes* were purchased from a dealer. Embryos of *O. latipes* Hd-rR inbred strain were kindly provided by Professor Akihiro Shima, University of Tokyo. The embryos were kept in indoor tanks under artificial reproductive conditions (10 hr dark and 14 hr light at 27°C) and were fed on Otohime B2 (Nisshin Seifun Group Inc., Tokyo, Japan).

Preparation of RNA

Total RNA was isolated from various adult organs of the orange-red variety of *O. latipes* by the acid guanidinium thiocyanate-phenol-chloroform extraction method (Chomczynski *et al.*, 1987). Poly(A)⁺RNA was prepared using Oligotex-dT30 (Roche, Basel, Switzerland), according to the manufacturer's protocol.

Amplification of cDNA fragments for membrane GCs by RT-PCR

Three degenerate oligonucleotide primers (P2, 5'-GAYATHGT-NGGNTTYAC-3'; P6, GTRTTNACNTRTCNCC-3'; P7, 5'-ARRCAR-TANCKNGGAT-3') were synthesized based on the amino acid sequences of 3 conserved regions (DIVGFT, MPRYCL, GDTVNT) in known membrane GCs and these primers were used to amplify membrane GC cDNA fragments from cDNA reverse-transcribed total RNA of the medaka fish ovary, as described previously (Seimiya *et al.*, 1997). The product was purified, subcloned into the plasmid vector pBluescript II KS(-) (Stratagene, La Jolla, CA, USA), and sequenced.

5'- and 3'-Rapid Amplification of cDNA Ends (5'- and 3'-RACE)

To obtain a full-length cDNA sequence of a new membrane GC clone referred to as *OIGC8*, the 5'- or 3'-portion of the cDNA was amplified by the 5'- or 3'-RACE method (Frohman *et al.*, 1988),

respectively, using the 5'-RACE System for Rapid Amplification of cDNA Ends, Ver 2.0 (Gibco BRL, Groningen, The Netherlands) or the 3'-Full RACE Core Set (Takara Shuzo Co., Ltd. Tokyo, Japan), as described previously (Yamagami *et al.*, 2001).

Total RNA (2 µg) isolated from the adult medaka fish ovary was reverse-transcribed with gene-specific antisense oligonucleotide primers (GSP1, GSP4, GSP7, and GSP10) and used as a template for 5'-RACE with the Abridged Anchor Primer (Life Technologies, Groningen, The Netherlands) and other gene-specific antisense oligonucleotide primers (GSP2, GSP5, GSP8, and GSP11). Amplification in the 5'-RACE was performed as follows: denaturation at 94°C for 5 min followed by 30 cycles of denaturation for 30 sec at 96°C, annealing for 1 min at 58°C, 61°C, 63°C, and 58°C, respectively, and extension for 90 sec at 72°C, and the final extension was carried out at 72°C for 10 min. To enrich the 5'-RACE products, a one-fifteenth volume of the primary products was reamplified by PCR using the Abridged Anchor Primer and nested primers (GSP3, GSP6, GSP9, and GSP12). PCR was performed under the same conditions as those used for GSP2, except for the amplification cycle (25 cycles) and the annealing temperature (58°C, 61°C, 62°C, and 55°C, respectively). On the other hand, 3 µg of total RNA was reverse-transcribed with an Oligo dT-3' sites Adaptor Primer (Takara Shuzo) for the 3'-RACE method. The cDNA was amplified by PCR with the 3' sites Adaptor Primer (Takara Shuzo) and another gene-specific oligonucleotide primer (GSP13). A one-fifteenth volume of the PCR product was amplified by PCR with 3' sites Adaptor Primer and another gene-specific oligonucleotide primer (GSP14). Amplification was performed under the same conditions as those used for GSP2, except for the amplification cycle and the annealing temperature (30 cycles at 63°C and 25 cycles at 62°C, respectively). The gene-specific primers used were complementary to the following nucleotide positions: 4281–4301 (GSP1), 3735–3754 (GSP2), 2568–2589 (GSP3), 1421–1440 (GSP4), 4252–4272 (GSP5), 3534–3555 (GSP6), 2538–2559 (GSP7), 1359–1377 (GSP8), 4147–4166 (GSP9), 3450–3471 (GSP10), 2511–2531 (GSP11), 1268–1286 (GSP12), 3643–3661 (GSP13), and 3809–3830 (GSP14). The RACE products overlapped at 53–655 bp with the 5' or 3' end of the isolated cDNA clone.

Molecular phylogenetic analysis

The deduced amino acid sequence of *OIGC8* was compared with those of various membrane GCs using the Clustal W program (Thompson *et al.*, 1994) and the sequence editor SeqPub (Gilbert, Indiana University, Bloomington, IN, USA). The unrooted phylogenetic tree was constructed using the aligned sequences by the neighbor-joining algorithms in the PROTRAS program of PHYLIP ver. 3.572 (Felsenstein, 1989) and the Clustal W program (Saitou and Nei, 1987). For the neighbor-joining analysis, the evolutionary distance was estimated using Kimura's empirical method for protein distances (Kimura, 1983). The following GenBank/EMBL/DBJ accession numbers for the sequences were used: X14773 (rat GC-A); M26896 (rat GC-B); M55636 (rat GC-C); L37203 (rat GC-D); L36029 (rat GC-E); L36030 (rat GC-F); AF024622 (rat GC-G); AB004921 (*OIGC1*); AB030274 (*OIGC2*); AB000899 (*OIGC3*); AB000900 (*OIGC4*); AB000901 (*OIGC5*); AB007192 (*OIGC6*); AB023489 (*OIGC7*).

Expression of *OIGC8* or medaka fish natriuretic peptide receptors in COS-7 cells

The whole protein-coding region of the *OIGC8* cDNA (nucleotides 2151–4865) or the cDNA (nucleotides 3827–4865) corresponding to the catalytic domain of *OIGC8* (CAT-8) was amplified by RT-PCR using the medaka kidney RNA. The primers used for the amplification were 5'-TTCATCGTCCGTCATCAGTCC-3' (sense) and 5'-CGTCAAACACGTGTGACGCTG-3' (antisense) for the whole protein, and those for the CAT-8 amplification were 5'-TCG-GTGCCGTTCTCATAACCC-3' (sense) and 5'-CGTCAAACACGT-

GTGACGCTG-3' (antisense). A medaka fish natriuretic peptide receptor/membrane GC (e.g., *OIGC1*, *OIGC2* or *OIGC7*) was also amplified by RT-PCR using the following primers: 5'-AGAATTCAA-GACGGTCGAGTGTCTCTCC-3' and 5'-CCGCTCGAGCGGGC-GACTCAGATAACGTAC-3' for *OIGC1*, and 5'-CAGAAGCTTCAC-TCTGTGGAAGTGGACC3' and 5'-CATCTAGACCTCTGTTCATC-TCATTGGC-3' for *OIGC2*, and 5'-GGAATTCTGGCTTATCATCAT-GGC-3' and 5'-CCTCTAGAGTCCCTTCATCCGTTTGTGATTATCC-3' for *OIGC7*. The amplified cDNA was subcloned into the expression vectors pCR3.1 using the Eukaryotic TA Cloning[®] Kit (Invitrogen).

COS-7 cells were maintained in Dulbecco's modified Eagle medium (DMEM) plus 10% heat-inactivated fetal bovine serum (FBS) (HyClone[®], Logan, UT, USA), 100 U/ml penicillin, 100 U/ml streptomycin, and 292 µg/ml glutamine (GIBCO[™]) under 5% CO₂-95% air at 37°C in a humidified atmosphere. One day before transfection, cells were plated at 4×10⁵ cells per well in a six-well plate (for the intracellular cGMP assay; Fig. 3C), at 2×10⁶ cells per 10-cm dish (for the assay of the GC activity in the membrane fraction; Fig. 3D), or at 8×10⁴ cells per well in a 24-well plate (for the intracellular cGMP assay; Fig. 4). Cells were transfected by lipofection with the plasmid DNA (2 µg of DNA/7.5 µl of LIPOFECTAMINE 2000 (LF2000) Reagent per well in a six-well plate; 6 µg of DNA/22.5 µl of LF2000 Reagent per 10-cm dish; 0.8 µg of DNA/2 µl of LF2000 Reagent per well in a 24-well plate) according to the manufacturer's protocol (Life Technologies, Inc.). As a control, pCR3.1 vector was transfected alone. Forty-eight hr after the addition of the respective construct DNA, the intracellular cGMP concentrations and the GC activity in the membrane fractions were determined.

Preparation of membranes and assay of membrane GC activity

For the preparation of the membrane fractions, COS-7 cells were plated in three 10-cm dishes and harvested 48 hr after transfection. Cells expressing *OIGC8* were washed twice with 5 ml of ice-cold phosphate-buffered saline (PBS) and then were scraped into a 0.5 ml dish containing an ice-cold solution consisting of the homogenization buffer and 1:1000 dilution of a Protease Inhibitors Mixture and DMSO solution for Mammalian Cell and Tissue Extracts (Wako Pure Chemical Industries, Ltd. Osaka, Japan). Cells were homogenized with a glass homogenizer and centrifuged for 1 hr at 2°C at 100,000×g. The resulting membrane pellet was washed twice with 500 µl of the homogenization buffer. The membranes were resuspended in 200 µl of the homogenization buffer and used for assaying the membrane GC activity or for the Western blot analysis.

Assays of membrane GC activity were performed in a 100 µl reaction mixture consisting of 50 mM NaCl, 0.25 mM IBMX, 0.1% BSA, 5 mM creatine phosphate, creatine phosphokinase (10 U), 1 mM GTP, 1 mM ATP, 5 mM MgCl₂/3 mM MnCl₂, and 25 mM HEPES, pH 7.4, as well as 0.1% Triton X-100, as indicated. The reaction was started by the addition of a membrane fraction to the reaction mixture and continued for 10 min at 37°C and stopped by addition of a 10% solution of trichloroacetic acid (TCA) to give a final concentration of 5%. TCA in the reaction solution was extracted with diethyl ether, and then the cGMP concentration was determined by PROTOCOL 1 of the cGMP enzyme immunoassay (EIA) system (Amersham Pharmacia Biotech., Buckinghamshire, UK) according to the manufacturer's protocol.

Immunological methods

A polyclonal antibody against *OIGC8* was created in rabbits using a synthetic peptide, YMTTESICGPWPIDDGKIF, corresponding to the amino acid sequence of a part of the extracellular domain (residues 114–132). The Western blot analysis was carried out essentially by the method of Towbin *et al.* (1979). The proteins of the membrane fractions prepared from COS-7 cells transfected with the *OIGC8* plasmid were separated on a 6% sodium dodecyl sulfate (SDS)-polyacrylamide gel and transferred electrophoretically to an

Immobilon™ PVDF membrane (Millipore, Bedford, MA, USA). After incubation with Block Ace (Dainippon Pharmaceutical Co. Ltd., Osaka, Japan) at 4°C overnight, the membrane was washed with PBST (137 mM NaCl, 2.7 mM KCl, 8.1 mM Na₂HPO₄, 1.5 mM KH₂PO₄, and 0.1% Tween 20) and incubated in a 1:1000 dilution of anti-OIGC8 rabbit anti-serum for 1 hr at room temperature. The membrane was washed three times with PBST and then reacted with a 1:3000 dilution of a horseradish peroxidase-linked anti-rabbit antibody (Amersham Pharmacia Biotech.) in PBST. After washing the membrane three times with PBST, the antibody-reacted protein bands were visualized using an enhanced chemiluminescence (ECL) detection kit (Amersham Pharmacia Biotech.).

Tissue extraction

Brain (402.1 mg), heart (96.7 mg), kidney (257.4 mg), testis (117.1 mg), and ovary (352.6 mg) tissues were obtained from 100 mature adult individuals of the orange-red variety of *O. latipes* and were homogenized in a five-fold weight/volume homogenization buffer containing 10% glycerol, 100 mM NaCl, 1 mM EDTA, and 50

mM HEPES, pH 7.4. The homogenate was then boiled for 10 min and cooled before centrifugation at 10,000 × g for 30 min at 4°C. The resulting supernatant sample (500 μl) was used for further experiments.

Intracellular cyclic GMP formation in intact COS-7 cells

The intracellular cGMP concentrations increased by transiently expressed membrane GC in intact COS-7 cells were determined by the method described by Koller *et al.* (1991). For the determination of cGMP accumulation in COS-7 cells expressing the appropriate plasmid DNA, the medium was exchanged with DMEM (without additives) containing 0.1 mM 3-isobutyl-1-methylxanthine (IBMX) at 37°C. After 10 min, the medium was exchanged with DMEM containing 0.1 mM IBMX without additives (Fig. 3C, or controls in Fig. 4) or with 1 μM each the following rat natriuretic peptide: ANP (28 amino acids), BNP-32, CNP (32-53), and C-ANP (4-23) (des [Gln¹⁸, Ser¹⁹, Gln²⁰, Leu²¹, Gly²²] ANP (4-23)-NH₂) (Peninsula Laboratories, Inc., San Carlos, CA, USA) or the medium was exchanged with 20 μl medaka fish tissue extract, and incubated for an addi-

Table 1. Primers used in LA-PCR analysis of the *OIGC8* gene

Primer No.	sense primers sequence	position in cDNA	Primer No.,	antisense primers sequence	position in cDNA	Exon No.	annealing temp.(°C)
3'-15	5'-CGATTCCACATTAACGGCTGG-3'	1263-1283	5'-23	5'-GTTTGCAGGACACTCGTGACGT-3'	2532-2511	1~ 5	62
3'-13	5'-TTCATCGTCCGTCCATCAGTCC-3'	2151-2172	5'-18	5'-AGTCAGACAGCTGGTGTGCTG-3'	3111-3090	2~10	60
3'-12	5'-TGTGGCGATTGTCCCATGA-3'	2869-2887	5'-10	5'-CTGAAGACGTCTCCAGCTAGC-3'	3668-3648	8~14	60
3'-19	5'-GAGGTTCCAAACATCGCC-3'	3310-3327	5'-04	5'-GTACGGCGTGCTGCTGCTGG-3'	4167-4148	12~20	63
3'-05	5'-CAACGCTAGCTGGAGACGT-3'	3644-3662	5'-01	5'-GAGGATGCCGTTCTCCTGAGG-3'	4302-4282	14~21	63
3'-08	5'-GTACAAGGTGGAGACCATCGG-3'	4233-4253	5'-C1	5'-CGTCAAACACGTGTGACGCTG-3'	4866-4846	20-24	63

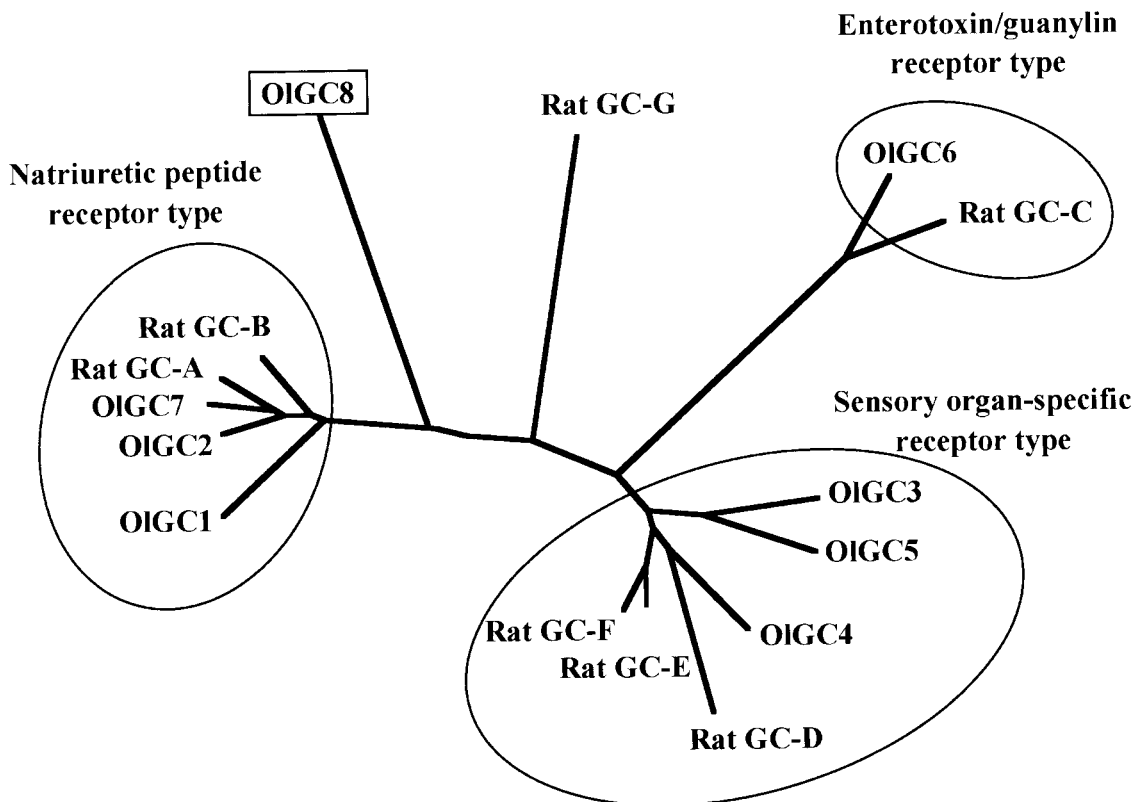

Fig. 1. Molecular phylogenetic analysis of the amino acid sequences of medaka fish and rat membrane GCs. The amino acid sequences of the catalytic domains of GCs were subjected to phylogenetic analysis (see "Materials and Methods").

tional 10 min. The reaction was stopped by replacing the medium with lysis reagent 1 working solution (cGMP EIA system) and the plate was shaken on a microplate shaker for 10 min at room temperature. The cGMP concentration was estimated by PROTOCOL 3 of the cGMP EIA system according to the manufacturer's protocol.

Southern blot hybridization

The Southern blot was carried out with the same membrane as that used in the previous study (Yamagami *et al.*, 2001). The membrane was reprobbed with boiled 0.5% SDS solution before pre-hybridization. A 319-bp *OIGC8* genomic DNA fragment (nucleotides

3552–3780) was labeled with [α -³²P] dCTP using the Random Primer DNA Labeling kit Version 2 (Takara Shuzo) and was used as a probe. The membrane was washed twice with 2×SSC containing 0.1% SDS and once with 1×SSC containing 0.1% SDS at 50°C for 15 min.

High-density replica membranes of a genomic DNA clone for *OIGC8* from a medaka fish bacterial artificial chromosome (BAC) library

High-density replica membranes of an *O. latipes* Hd-rR inbred strain genomic BAC library were used for the screening (Matsuda

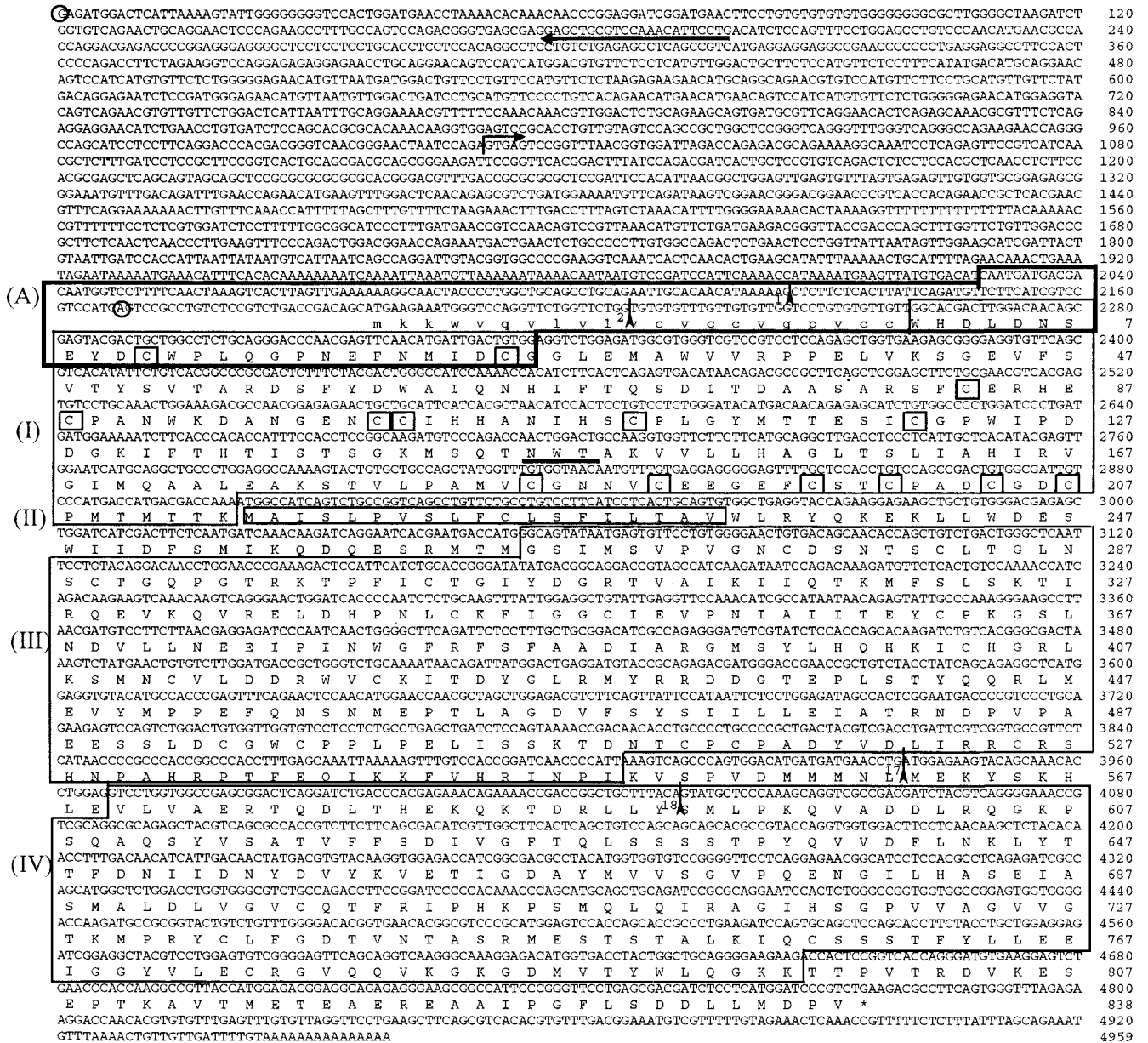

Fig. 2. The nucleotide and deduced amino acid sequences of *OIGC8* cDNA. The deduced amino acid sequence is indicated by the single-letter code. The signal peptide sequence is indicated by lower-case letters. The amino acids are numbered relative to the predicted signal cleavage site (+1). A potential N-linked carbohydrate binding site is underlined. Open boxes denote cysteine residues in the extracellular domain. A stop codon is indicated by an asterisk. Open boxes (I) ~ (IV) indicate the extracellular, transmembrane, kinase-like, and cyclase catalytic domains, respectively. Open box (A) indicates the region used for the probe in the RNase protection analysis. The first and second transcription initiation sites are indicated by an open circle. The upstream-pointing arrow inside the 5'-UTR designates the site used to form the primers for the primer extension analysis (see Fig. 7). The downstream-pointing arrows inside the 5'-UTR designate the site which was deleted by splicing in the testis tissue samples (see Fig. 9A). The four arrowheads point out the sites of introns 1, 2, 17, and 18.

et al., 2001). The membrane preparation and the screening method were essentially performed as described previously (Yamagami *et al.*, 2001). To isolate the BAC clone containing the *OIGC8* gene, the hybridization was carried out using a probe made by PCR using the *O. latipes* Hd-rR inbred strain genomic DNA as a template and the following primers: the 5'-C1 primer (5'-CAGGTGGTGGACTTCCTCAAC-3') and the 3'-5 primer (5'-CAACGCTAGCTGGAGACGT-3'). Genomic DNA was isolated from one individual of *O. latipes* Hd-rR inbred strain, as described previously (Yamagami *et al.*, 2001).

QIAGEN plasmid midi and maxi kits (QIAGEN, Hilden, Germany) were used for BAC DNA isolation from the bacterial culture. Based on the nucleotide sequence of the *OIGC8* cDNA, various specific oligonucleotide primers were designed to amplify the intron regions of positive BAC clones and to effectively carry out sequencing (Table 1). Long and accurate polymerase chain reaction (LA-PCR) was performed using a combination of these primers under the following conditions: after an initial denaturing step of 5 min at 94°C, the PCR was carried out with 30 cycles of denaturation for 20 sec at 98°C, followed by annealing and extension for 20 min at 59–68°C (depending on the primers), and a final extension at 72°C for 10 min. Primers positioned in the exon were used to determine the intron size by PCR of the positive BAC clone DNA used as a

template. The PCR product was also subcloned into the plasmid vector pBluescript II KS(-) or KS(+) (Stratagene) and sequenced.

Primer extension analysis

In order to identify the transcription start site, a primer extension experiment was carried out as described previously (Yamagami *et al.*, 2001). A ³²P-end-labeled oligonucleotide primer (5'-TGT-CAGGAATGTTTGGACGC-3'; 5×10⁴cpm) was hybridized with 5 µg of the medaka fish ovary poly(A)⁺RNA under the following conditions: hybridization took place in a total of 20 µl of 10 mM Tris-HCl (pH 8.3) containing 1 mM EDTA and 0.25 M KCl kept at 65°C for 90 min and then at room temperature for 90 min or in a 10 µl solution containing 2 M NaCl and 50 mM PIPES (pH 6.4) kept at 85°C for 2 min and then at 56°C for overnight.

Northern blot hybridization

Northern blot analysis was performed using poly(A)⁺RNA (7.5 µg) isolated from the adult medaka fish brain, gill, kidney, testis, and ovary, and a nucleotide fragment corresponding to the *OIGC8* cDNA (nucleotides 1607–2115 or 2151–2937) was used as a probe according to a previously described procedure (Yamagami *et al.*, 2001). The membrane was washed twice with 2×SSC containing

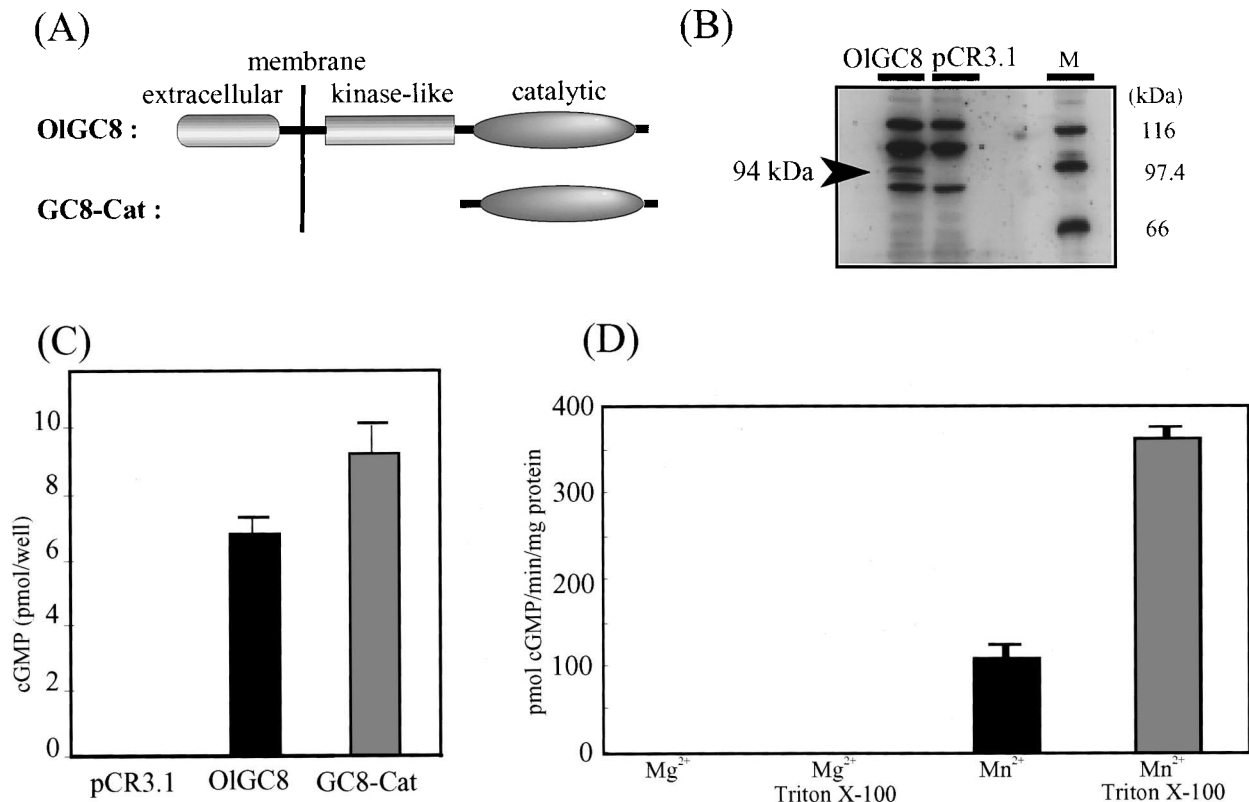

Fig. 3. Guanylyl cyclase activity in COS-7 cells overexpressing OIGC8. **(A)** The schematic diagram of OIGC8 and GC8-CAT. OIGC8 contained an extracellular domain, a transmembrane domain, and intracellularly, a kinase-like domain and a catalytic domain. GC8-CAT encoded only the catalytic domain. **(B)** Immunoprecipitation of OIGC8 expressed in COS-7 cells. The COS-7 cells transfected with *OIGC8* or the expression vector (pCR3.1) were homogenized and immunoprecipitated with the polyclonal antibody specific to the extracellular domain of OIGC8 and the cells were analyzed on a 6% polyacrylamide gel, as described in Materials and Methods. The arrowhead indicates a 95 kDa-protein which was the only protein to specifically react with the antibody. **(C)** The cGMP concentrations in COS-7 cells transfected with *OIGC8*, *GC8-CAT*, and pCR3.1 expression vector in a 6-well plate. Cells were incubated twice for 10 min at 37°C in the presence of 0.1 M IBMX. The transfection and cGMP assay were carried out four times independently, and the data are expressed as means ± S.D. **(D)** Membranes of COS-7 cells expressing OIGC8 in the 10-cm dish were assayed for GC activity. Membrane fractions were incubated in a reaction mixture in the presence of 5 mM Mg²⁺, 5 mM Mg²⁺ and 0.1% Triton X-100, 5 mM Mn²⁺, or 5 mM Mn²⁺ and 0.1% Triton X-100 for 10 min at 37°C and the reaction was stopped by the addition of TCA (at a final concentration of 5%).

0.1% SDS at 42°C for 15 min and with 0.1×SSC containing 0.1% SDS for 10 min at 50°C.

RNase protection analysis

An RNase protection experiment was carried out using the total RNA (10 µg) prepared from various adult medaka fish organs and an antisense cRNA probe transcribed from the 5'-noncoding region corresponding to nucleotides 2029-2336 of the *OIGC8* cDNA, as described previously (Yamagami *et al.*, 2001). A plasmid containing a cDNA fragment of the 3'-noncoding region (1741-1840) of medaka fish cytoplasmic actin gene *OICA1* (Kusakabe *et al.*, 1999) was used as a template for the synthesis of a cRNA probe.

RNA Ligase-Mediated Rapid Amplification of cDNA Ends (RLM-RACE), and Reverse Transcription-Polymerase Chain Reaction (RT-PCR)

To confirm the sequence of the 3.3 kb-*OIGC8* mRNA, the 5'-portion of the cDNA was amplified by the RLM-RACE method (Maruyama and Sugano, 1994) using the First Choice™ RLM-RACE Kit (Ambion, Austin, TX, USA). This experiment was carried out using the total RNA (5 µg) isolated from the adult medaka fish brain and the 5' RLM-RACE kit according to the manufacturer's standard protocol. After the reaction of reverse transcription, PCR was performed as follows: denaturation at 94°C for 3 min followed by 30 cycles of denaturation for 30 sec at 96°C, annealing for 30

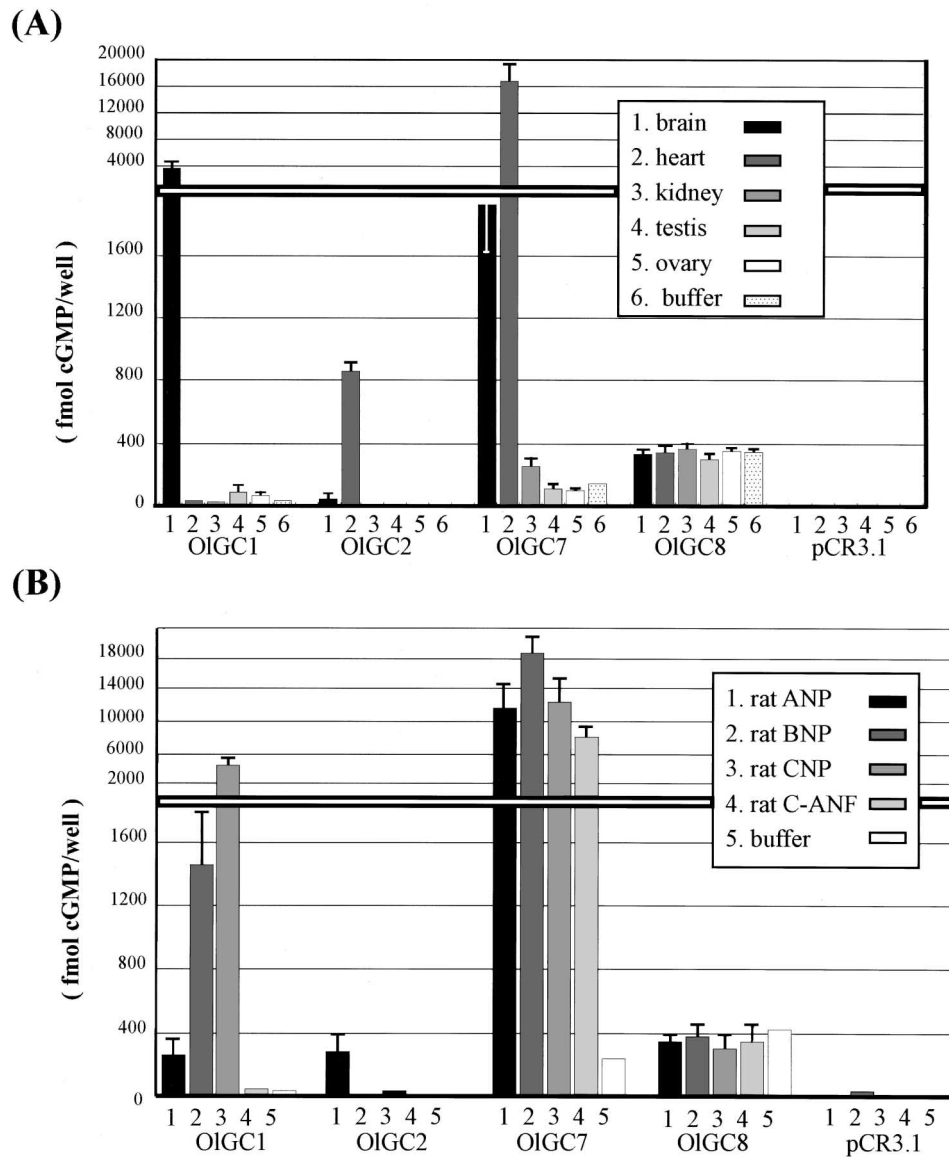

Fig. 4. GC activity of OIGC8 and three medaka natriuretic peptide receptors with various medaka fish tissue extracts or rat natriuretic peptides. COS-7 cells expressing the appropriate receptor (OIGC1, OIGC2, OIGC7, or OIGC8) or empty expression vector (pCR3.1) in a 24-well plate were treated with the medaka fish tissue extract (A), with 1 µM rat natriuretic peptides (B), or with medium alone, and then the intracellular cGMP concentrations were determined. Transfection and cGMP assays were performed four times independently, and the resulting values are expressed as means ± S.D. (A) medaka fish tissue extracts: 1, brain; 2, heart; 3, kidney; 4, testis; 5, ovary; 6, control (medium alone). (B) rat natriuretic peptides: 1, ANP; 2, BNP; 3, CNP; 4, C-ANF; 5, control (medium alone).

sec at 60°C, and extension for 2.5 min at 72°C, and the final extension was carried out at 72°C for 10 min. The 5'-RACE Outer Primer and gene-specific antisense oligonucleotide primer 5'-23 (nucleotides 2511–2532) were used for Outer 5' RLM-RACE PCR. A 1:25 volume of the primary products was reamplified by PCR using the same conditions as those given above; Inner 5'-RACE Inner Primer was used for this experiment, and gene specific primer 5'-63 (nucleotides 2313–2333) was used for Inner 5' RLM-RACE PCR.

For RT-PCR to detect that no excision of introns had taken place, 5 µg of total RNA from various adult medaka fish organs was used as a template to synthesize the first-strand cDNA using an oligo(dT) primer according to the manufacturer's protocol (Super Script Preamplification System for First Strand cDNA Synthesis). The cDNA fragment containing the catalytic domain of *OIGC8* was amplified by PCR from the of medaka fish brain. The primer pair used was as follows: 5'-TCGGTGCCGTTCTCATAACCC-3' (identical to nucleotides 3828–3848) and 5'-CGTCAACACGTGTGAC-GCTG-3' (complementary to nucleotides 4846–4866).

To determine the sequences of several spliced variants from the testis, we carried out RT-PCR using the testis and kidney first strand cDNA of medaka fish. The primer pair used was as follows: 5'-CCTGTGATCTCTGCACGCTC-3' (identical to nucleotides 1288–1308 in the genome) and 5'-AGCAGTTCTCTCCGTTGGCGTC-3' (complementary to nucleotides 3849–3870 in the genome). The RACE and RT-PCR products were purified and subcloned into the plasmid vector pBluescript II KS(–) (Stratagene).

Other methods

SDS-polyacrylamide gel electrophoresis (SDS-PAGE) was car-

ried out essentially as described by Laemmli (1970). The protein concentration was determined by the method of Schacterle and Pollack (1973). The nucleotide sequence was determined by the dideoxy chain termination method (Sanger *et al.*, 1977) with an Applied Biosystems 377 sequencer or a 3100 Genetic Analyzer, and analyzed with DNASIS software (Hitachi Software Engineering Co., Yokohama, Japan) and GENETY X-MAC/version 7.2.0. (Software Development Co., Ltd. Tokyo, Japan).

Alignment of the amino acid sequences was carried out using ClustalW available on WWW Service at the European Bioinformatics Institute (URL; <http://www.ebi.ac.uk/clustalw>) (Thompson *et al.*, 1994). Transcription-factor binding sequences within the enhancer element were scanned using the TFSEARCH program from GenomeNet (<http://www.rwcp.or.jp/papia/>) (Heinmeyer *et al.*, 1998). Genome sequences held on the Ensembl Genome Browser (<http://www.ensembl.org/>) and the Fugu database (UK HGMP-RC; <http://fugu.hgmp.mrc.ac.uk>) were analyzed using the BLAST or TBLASTN search programs available at the site.

RESULTS

Isolation and characterization of cDNA clone encoding *OIGC8*

The comparison of the nucleotide and deduced amino acid sequences of a 341 bp-cDNA fragment obtained from the medaka fish ovary by RT-PCR with those of known vertebrate and invertebrate membrane GCs indicated that the

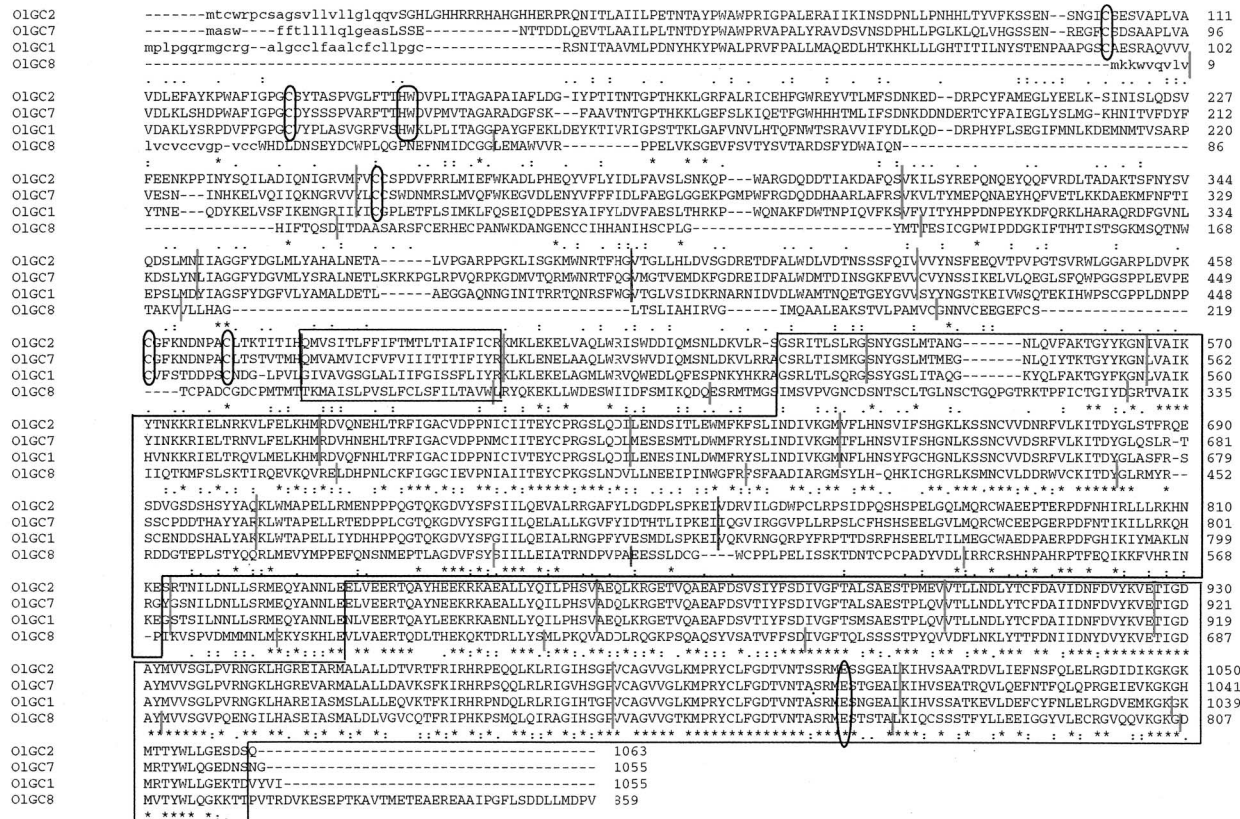

Fig. 5. Alignment of the amino acid sequence of OIGC8 with that of three medaka fish natriuretic peptide receptor/membrane GC homologs. The signal peptide sequence is indicated by lowercase letters. The identical amino acid residues among four proteins are indicated by asterisks below the sequence. Gaps in the sequence are indicated by dashes (–). The locations of introns are indicated by vertical bold lines. Open boxes indicate the transmembrane, kinase-like, and cyclase catalytic domains. Open circles indicate the conserved Cys and His-Trp residues. The open circle by the striped line in catalytic domain is represented by E, as reported in the mutagenesis analysis (Wedel *et al.*, 1997).

cDNA fragment is similar but not identical to those of other known membrane GCs (Fig. 1). We obtained the full-length cDNA clone (referred to as *OIGC8*) by repeated 5'-RACE (4 times) and 3'-RACE, the products of which overlapped at 46-1150 bp with the end of the clone that had been isolated. The complete *OIGC8* cDNA was 4958 bp in length and consisted of a 2196-bp 5'-untranslated region (UTR), a 2577-bp open reading frame (ORF), and a 186-bp 3'-UTR. Termination codons occurred in all three frames upstream of the putative initiation codon (ATG) and the nucleotides around the putative initiation codon fit the preferred sequence context for the initiation of protein synthesis in eukaryotic mRNAs (Kozak, 1983). The ORF of *OIGC8* cDNA predicted a protein of 859 amino acids and contains an amino-terminal signal sequence of 21 amino acids (Kyte and Doolittle, 1982; von Heijne, 1983). The mature protein with 838 amino acids was composed of a rather small extracellular domain (residues 1–214), a transmembrane segment (residues 215–233), an intracellular protein kinase-like domain (residues 266–549), and a cyclase catalytic domain (residues 569–796). The comparison of the amino acid sequence of *OIGC8* with those of other known membrane GCs indicated a very low degree of similarity in the extracellular domain. There were 14 Cys residues in the extracellular domain of *OIGC8*, and only one potential N-linked carbohydrate binding site was identified in the domain (Fig. 2). The amino acid sequence identity in the catalytic domain of *OIGC8* to that of rat GC-G, rat GC-A, rat GC-B, and medaka fish *OIGC1* was 56%, 61%, 61%, and 62%, respectively.

Expression of *OIGC8* activity

To confirm whether or not the *OIGC8* gene encodes an active GC, the whole cDNA or the cDNA fragment for the catalytic domain was expressed in COS-7 cells and the GC activity was measured (Fig. 3A). As shown in Fig. 3B, Western blot analysis using the antibody specific to the extracellular domain of *OIGC8* demonstrated that a 95 kDa protein was the only protein that specifically reacted with the antibody when the membrane proteins prepared from COS-7 cells transfected with the *OIGC8* construct for the whole protein were used. The molecular mass of the former protein corresponded to a molecular weight of 93,780, as calculated based on the amino acid composition of *OIGC8*. As shown in Fig. 3C, the cGMP concentrations in COS-7 cells transfected with the *OIGC8* construct for the whole protein or with a 283 amino acid fragment (the putative catalytic domain) were significantly higher than those with vector (pCR3.1) alone. The membrane fractions prepared from COS-7 cells transfected with the *OIGC8* construct for the whole protein exhibited higher GC activity in the presence of Mn^{2+} /Triton X-100 than that in the presence of Mn^{2+} alone (Fig. 3D).

To examine whether or not adult medaka fish tissues contain specific ligands for *OIGC8* in addition to the already isolated and characterized putative medaka fish natriuretic peptide receptors (*OIGC1*, *OIGC2*, and *OIGC7*), we tested the effects of various medaka fish tissue extracts on COS-7

cells transfected with the *OIGC8* construct as well as the *OIGC1*, *OIGC2* or *OIGC7* construct. As shown in Fig. 4A, the cGMP concentrations in COS-7 cells transfected with the *OIGC8* construct retained the basal level in the presence as well as in the absence of tissue extract. However, the cGMP concentrations in COS-7 cells transfected with the *OIGC1* construct were increased by addition of the brain extracts and those transfected with the *OIGC2* construct were increased by heart extract. Both the brain and heart extracts increased the cGMP concentrations in COS-7 cells transfected with the *OIGC7* construct. As shown in Fig. 4B, rat BNP and CNP activated *OIGC1*, which was expressed in COS-7 cells; rat ANP activated both *OIGC1* and *OIGC2*, although rat C-ANF did not stimulate the activity of *OIGC1* and *OIGC2* expressed in COS-7 cells. Moreover, all of the rat natriuretic peptides (ANP, BNP, CNP, and C-ANF) stimulated the GC activity of *OIGC7* expressed in COS-7 cells much more effectively than they stimulated the GC activity of *OIGC1* and *OIGC2*, which were expressed similarly in the COS-7 cells; however, *OIGC8* remained at a constant low level of activity with or without tissue extract or rat natriuretic peptides.

The comparison of the deduced amino acid sequence of *OIGC8* with those of three putative medaka fish natriuretic peptide receptors, *OIGC1*, *OIGC2* and *OIGC7* is shown in Fig. 5. The positions and the number of Cys residues in the extracellular domain differ between *OIGC8* and the other three *OIGCs*. The His-Trp residues, which are considered to be the ligand-binding site and are conserved in the three

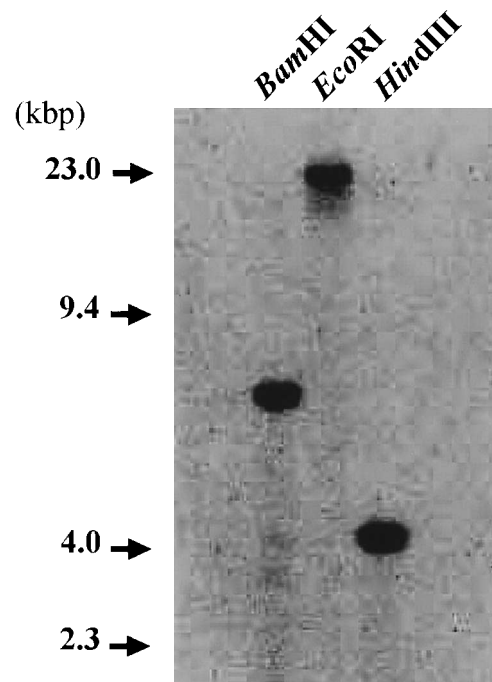

Fig. 6. Genomic Southern hybridization analysis. Genomic DNA (10 μ g) from a single individual of the *O. latipes* Hd-rR inbred strain was digested with *Bam*HI, *Eco*RI, or *Hind*III. The blot was hybridized with a 32 P-labeled *OIGC8* cDNA probe.

putative medaka fish natriuretic peptide receptors, were not seen in *OIGC8* in the corresponding positions.

Genomic Southern analysis

Southern blot hybridization using the medaka fish (Hd-rR strain) genomic DNA demonstrated that the *OIGC8* probe produced only one positive signal in each of the three lanes (Fig. 6). The size of the band in each lane was consistent with that of the DNA fragment obtained from digestion of the genomic DNA by the restriction enzymes, suggesting that a single *OIGC8* gene exists in the medaka fish genome.

Characterization of a genomic DNA clone for *OIGC8*

A genomic BAC library of the *O. latipes* Hd-rR strain was screened with a genomic DNA fragment of *OIGC8* (nucleotides 3644–4866, including exons/introns 14–24) used as a probe. By sequencing a positive BAC clone, we obtained a complete nucleotide sequence of the *OIGC8* gene with 14.3 kbp consisting of 24 exons and a promoter region (Fig. 7). The nucleotide sequences of all the splice junctions were in good agreement with the GT/AG rule (Mount, 1982). The exon-intron organization and the exon sizes were completely different from those of mammalian GC-A or medaka fish natriuretic peptide receptor/membrane GCs (Fig. 5). The 5'-UTR of the *OIGC8* cDNA was rather big and there was an intron 1 at the end of the 5'-UTR.

Identification of the 5'-end nucleotide of the *OIGC8* transcripts by primer extension analysis

As shown in Fig. 7 (box at the lower left), a primer extension analysis demonstrated that the 5'-end nucleotide was at the nucleotide position 2196 bp (G) upstream of the putative initiation codon, as shown by using poly(A)⁺ RNA from the ovary; this finding indicated that the complete *OIGC8* cDNA is 4958 bp in length and possesses a 2196-bp 5'-untranslated region (UTR). There was no typical TATA box in the 5'-flanking region upstream of the first putative transcription initiation site of the *OIGC8* gene.

Tissue-specific expression of different sizes of the *OIGC8* transcripts

As shown in Fig. 8A, Northern blot hybridization using poly(A)⁺ RNA from the adult medaka fish tissues and using a cDNA fragment corresponding to the 5'-UTR as a probe (Fig. 7, probe A) demonstrated the existence of a 5 kb-*OIGC8* transcript in the kidney and testis. However, when a cDNA fragment corresponding to exon 2 to exon 8 encoding the extracellular domain of *OIGC8* (Fig. 7, probe B) was used as a probe for hybridization using the same membrane, another signal at a position corresponding to 3.3 kb was detected with the brain poly(A)⁺RNA, whereas a signal at 5 kb was also detected with poly(A)⁺RNA from the kidney and testis (Fig. 8B). To clarify how the 3.3 kb-mRNA was

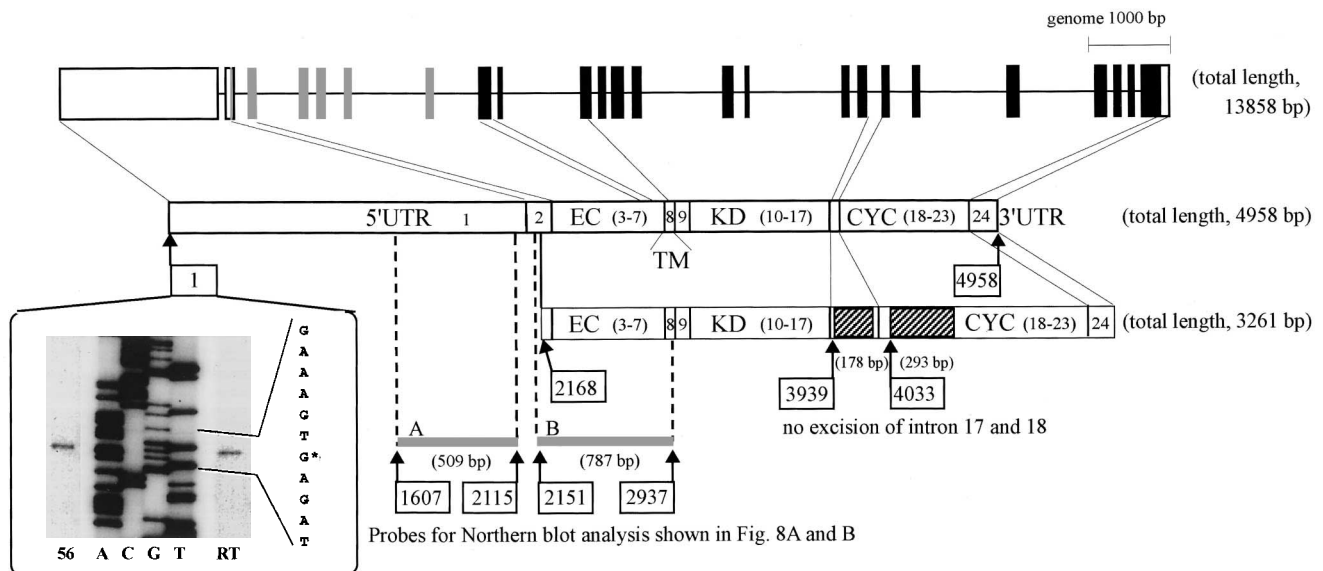

Fig. 7. Genomic structure and schematic diagram of cDNA of *OIGC8* and identification of the transcription initiation site by primer extension analysis of the *OIGC8* gene. The open boxes indicate 5'- and 3'-untranslated regions, and the solid boxes show protein coding regions in the genomic structures. Introns are indicated by lines. Two schematic diagrams of cDNAs are presented under the genomic structure. Exon numbers are shown in the cDNA structure. ECD, extracellular domain; TM, transmembrane domain; KLD, kinase-like domain; CYC, cyclase catalytic domain. The numbers inside the open boxes indicate the nucleotide position in the cDNA. The regions of the probe using Northern blot analysis are shown as two bars under the structure of the cDNA. A lack of excision of introns 17 and 18 is indicated by two striped boxes inside the 3261 bp-cDNA. The box at the lower left indicates the results of the primer extension analysis. A radiolabeled antisense oligonucleotide primer corresponding to the 20 bp (183–202; indicated by an arrow in Fig. 2) for *OIGC8* was hybridized with 5 µg of poly(A)⁺RNA isolated from the medaka fish ovary. In order to produce the sequence ladder, a dideoxy DNA sequencing reaction of *OIGC8* genomic DNA was performed using the same antisense oligonucleotide primer. The corresponding nucleotide in the sequencing ladder is marked by an asterisk (*). The hybridization was carried out at 65°C for 90 min and then was continued at room temperature (RT) for 90 min, and the other hybridization was performed at 85°C for 2 min and then was maintained at 56°C overnight.

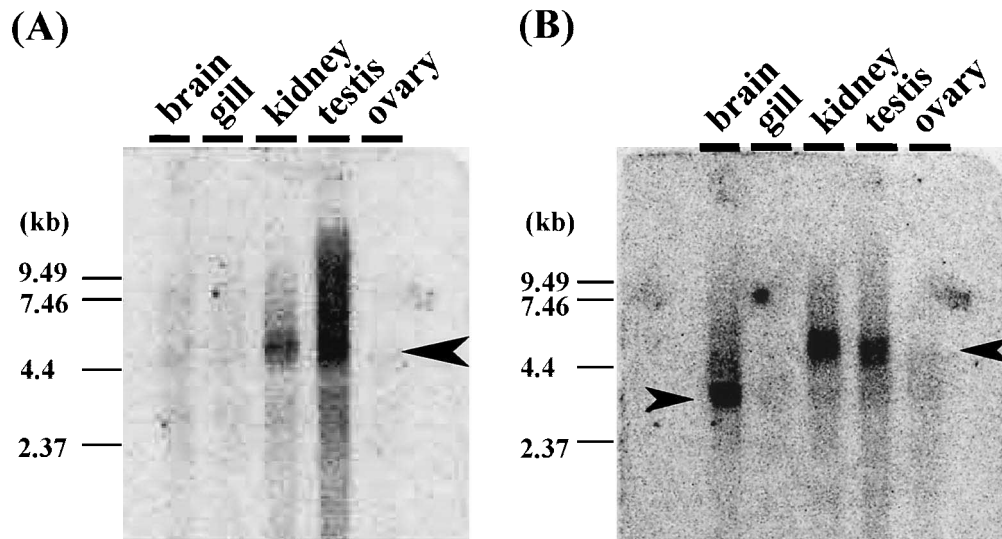

Fig. 8. Northern blot analysis of the *OIGC8* transcripts in various adult medaka fish organs. **(A)** and **(B)** Northern blot analysis was carried out using poly(A)⁺RNA (7.5 µg) from the brain, gill, kidney, testis, and ovary. The radioactive bands are indicated by arrowheads. The positions and sizes of the RNA markers are shown on the left. The same blot was hybridized with a ³²P-labeled cDNA probe for a portion of the 5'-UTR **(A)** or the extracellular domain **(B)** of *OIGC8* (see Fig. 7).

produced in the brain, an RNase protection assay was carried out using a probe complementary to the 306 bases of the 5 kb-mRNA (Fig. 9A, striped arrow). As shown in Fig. 9B (arrowhead A), a strong signal at 306 bp due to the 5 kb-*OIGC8* transcript was detected with poly(A)⁺RNA from the kidney and testis, and a weak signal at 306 bp due to the 5 kb-*OIGC8* transcript was detected with that from the ovary and brain. Another band migrated between 154 and 201 bp, which was thought to be the result of the protection of the last 168 bp of the probe (Fig. 9A, arrow C; Fig. 9B, arrowhead C); this latter band was detected only in the case of the brain poly(A)⁺RNA. On the other hand, several different bands with weak intensity were detected in the poly(A)⁺RNA of the kidney and testis; these bands were located somewhat under the 220 bp marker, a finding which was attributed to the protection of the last 210 bp of the probe (Fig. 9A, arrow B; Fig. 9B, arrowhead B). Moreover, three weak bands migrated between 75 bp and 134 bp, and were detected in the testis samples (Figs. 9A and 9B, arrow d, e, f).

A variety of sizes of *OIGC8* transcripts were detected in the brain samples, and were also detected in the samples from the kidney and testis; the presence of these different transcripts in the kidney and testis were confirmed by RT-PCR (Fig. 8). A band protected at about 210 bp was due to an mRNA which was thought to be spliced starting at 1010 bp (Fig. 9A, broken line and arrow in 5'-UTR) to 2126 bp of the cDNA nucleotides (Fig. 9A, arrow B). The nucleotide position at 2126 bp was located at the first intron, and the nucleotide position at 2227 bp was located at the second intron. As seen in the RT-PCR products, we detected several different sizes of *OIGC8* transcripts in the testis, most likely due to a deletion from somewhere between the nucleotide position at 1010 bp to the first or second intron site (Fig. 9A, arrow B, d), or else due to deletion of a nucleotide

near intron 2 (Fig. 9A, arrow e, f). This finding was in good agreement with the RNase protection analysis, which revealed that a fragment of approximately 80-90 bp cDNA was protected between 75 bp to 134 bp (Fig. 9B, asterisk*) when the testis sample was examined.

Identification of the 5'-end nucleotide of the 3.3 kb-mRNA by RNA Ligase-Mediated Rapid Amplification of cDNA Ends (RLM-RACE) and Reverse Transcription-Polymerase Chain Reaction (RT-PCR)

Since Northern blot and RNase protection analyses indicated that a 3.3 kb-mRNA is a major *OIGC8* transcript in the adult medaka fish brain, it became important to assign the 5'-end nucleotide of the 3.3 kb-mRNA in order to clarify how this mRNA was formed. We employed the RLM-RACE method for the assignment of the 5'-end nucleotide. The nucleotide was detected at the nucleotide position at 2168 bp (A) downstream of the first transcription site using the adult medaka fish brain total RNA; this site was referred to as the second putative transcription initiation site. The size of an mRNA transcribed from the second putative transcription initiation site was estimated to be 2790 b. To determine whether or not the second transcription initiation site was for the 3.3 kb-mRNA, we amplified a partial *OIGC8* mRNA expressed in the medaka fish brain by RT-PCR using *OIGC8* specific primers, and we obtained two cDNA fragments of different sizes that encoded the catalytic domain. Subsequent sequencing of these RT-PCR products revealed that the shorter cDNA fragment (1039 bp) corresponded to the normal *OIGC8* cDNA and the longer cDNA fragment (1510 bp) corresponded to a *OIGC8* cDNA with intron 17 (178 bp) and intron 18 (293 bp) (Fig. 7, striped boxes in the schematic cDNA structure depicted at the bottom).

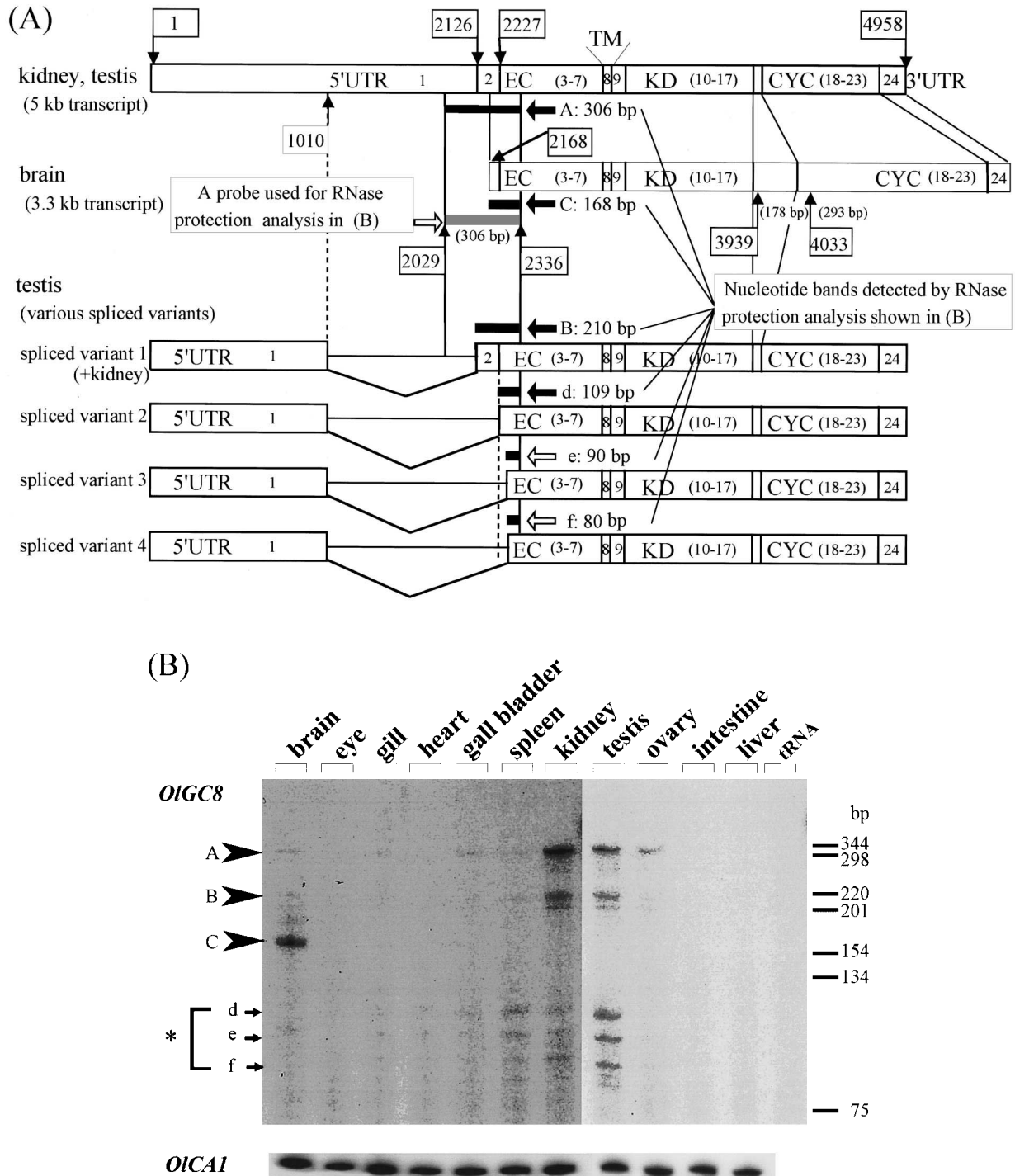

Fig. 9. Schematic diagram of *OIGC8* cDNA expressed in kidney, brain, or testis, and the position of the probe used for RNase protection analysis and depiction of the regions of several protected bands, and RNase protection analysis of *OIGC8* transcripts. (A) The upper schematic diagram denotes cDNA expressed in the kidney and testis. The second schematic diagram indicates cDNA expressed in the brain. The lower four diagrams denote spliced variants of cDNA expressed in the testis. The grey bar indicate probe using RNase protection analysis, and the protected bands are shown as black bars (A, B, C, d, e, f) pointed at by black or white arrows. The black arrows indicate that the sequence of the protected band represented by the bar was confirmed by sequencing, and the white arrows indicate that the sequence of the protected band indicated by the bar remains unknown. (B) RNase protection analysis of the *OIGC8* transcripts in various adult medaka fish organs. Total RNA (10 μ g) obtained from various medaka fish organs was hybridized with an antisense cRNA probe (172 nucleotides) for *OIGC8*. An antisense cRNA probe for *OICA1* (100 nucleotides) was used as an internal control. After digestion with RNase, the protected fragments were separated by electrophoresis on a 6% polyacrylamide/7 M urea gel and autoradiographed.

DISCUSSION

In this study, we isolated a new membrane GC (*OIGC8*) from the medaka fish, *O. latipes*, which does not belong to any known membrane GC groups, e.g., natriuretic peptide receptors, sensory organ-specific GCs, heat-stable enterotoxin/guanylin receptors, or orphan receptor-type GC (such as rat GC-G) (Schulz *et al.*, 1998). The *OIGC8* cDNA contained a long 5'-UTR (2196 bp) and a short extracellular domain-coding region (641 bp), the size of which was only half that of other known membrane GCs. The intron/exon boundaries of the *OIGC8* gene were completely different from those of the other known medaka fish membrane GC genes (*OIGC1-OIGC7*). On the other hand, the amino acid sequences of the intracellular kinase-like and cyclase catalytic domains of *OIGC8* were similar to those of the putative medaka fish natriuretic peptide receptors (*OIGC1*, *OIGC2*, and *OIGC7*) (Fig. 5), and were also similar to the other known vertebrate membrane GCs (data not shown). Furthermore, the whole protein, overexpressed in COS-7 cells, showed an increase in intracellular cGMP concentrations in the cells (Fig. 3C). It was also found that membrane fractions prepared from *OIGC8*-transfected COS-7 cells exhibited GC activity in the presence of Mn^{2+} , and much higher activity in the presence of Mn^{2+} and Triton X-100 (Fig. 3D), which is typical for membrane GCs (Potter and Garbers, 1992). Therefore, we concluded that the *OIGC8* gene is a novel type of membrane GC gene.

It has previously been reported that the natriuretic peptide receptor/membrane GCs are regulated negatively by a kinase-like domain and that they are activated by the binding of ligands to the extracellular domain or by the binding of intracellular activators to the kinase-like domain (Chinkers and Garbers, 1989; Sharma, 2002). Wedel *et al.* (1997) reported that a single point mutation (Glu⁹⁷⁴ to Ala) within the catalytic domain of rat GC-A results in a constitutively hyperactive enzyme due to a release from negative regulation by a protein kinase-like domain; that finding indicated that Glu⁹⁷⁴ is a key amino acid residue for negative regulation by the protein kinase-like domain. As shown in Fig. 3C, the whole protein and the catalytic domain alone of *OIGC8* expressed in COS-7 cells increased the intracellular cGMP concentrations in the cells to almost the same levels as those observed with or without the addition of any known ligands such as ANP, BNP, CNP, and C-ANF; this finding suggests that the kinase-like domain of *OIGC8*, the catalytic domain of which contained an Asn residue in the position corresponding that of Glu⁹⁷⁴ in the catalytic domain of GC-A (Fig. 5), did not suppress the catalytic domain of *OIGC8*. However, as shown in Fig. 4A, the tissue extracts prepared from the kidney and testis, in which the *OIGC8* gene was expressed abundantly, and natriuretic peptides (e.g., ANP, BNP, CNP, and C-ANF) did not activate *OIGC8* expressed in COS-7 cells, whereas *OIGC1*, *OIGC2*, and *OIGC7*, expressed similarly in COS-7 cells, were differentially activated tissue-specifically by the extracts and natriuretic pep-

tides (Fig. 4B). It has previously been reported that the extracellular domain of the known natriuretic peptide receptors possesses five to seven conserved Cys residues considered to be important for the formation of specific conformations for ligand-binding (Itakura *et al.*, 1994; Stults *et al.*, 1994) and conserved His-Trp residues considered to be the ligand-binding site (Iwashina *et al.*, 1994). As shown in Fig. 5, the extracellular domains of *OIGC1*, *OIGC2*, and *OIGC7* contain such conserved residues, although there were no such conserved residues in the extracellular domain of *OIGC8*. All of these findings, when taken together, indicate that it is difficult for ligands such as ANP, BNP, CNP, and C-ANF to bind to the extracellular domain of *OIGC8*, and that no small peptidic ligand specific for *OIGC8* is present in these medaka fish tissues. Therefore, we presume that *OIGC8* is a novel orphan receptor-type membrane GC, although the present findings do not rule out the possibility that the medaka fish contains unknown protein factors such as GCAP1 or GCAP2 which may regulate *OIGC8* by binding to its intracellular domain. However, the mechanisms responsible for the regulation of *OIGC8* activity remain unclear at this point in time.

It has previously been reported that GC-A is activated by both ANP and BNP, both of which are synthesized and secreted from the heart (Bloch *et al.*, 1986; Forssmann *et al.*, 1998), and that GC-B is activated by CNP, which is synthesized in the brain (Koller *et al.*, 1991; Sudoh *et al.*, 1990). In a previous study, we suggested that *OIGC1*, *OIGC2*, and *OIGC7* are the medaka fish homolog of the respective mammalian natriuretic peptide receptor (Takeda and Suzuki, 1999; Yamagami *et al.*, 2001), i.e., *OIGC1* is the homolog of GC-B, and *OIGC2* and *OIGC7* are the homologs of GC-A; however, no medaka fish natriuretic peptide has been isolated to date. Actually, as shown in Fig. 4, *OIGC1* was activated significantly by CNP as well as by the medaka fish brain extracts, and *OIGC2* was activated by ANP and the medaka fish heart extracts. On the other hand, the ligand specificity of *OIGC7* was rather broad and *OIGC7* was activated by various medaka fish tissue extracts (brain, heart, kidney, testis, and ovary) and by various natriuretic peptides (ANP, BNP, CNP); in fact, *OIGC7* was even activated by C-ANF, which is known to bind only to the natriuretic peptide clearance receptor, NPR-C (Anand-Srivastava *et al.*, 1990). To the best of our knowledge, no paper has yet demonstrated the activation of any type of natriuretic peptide receptor by C-ANF. Along these lines, *OIGC7* is known to be a unique natriuretic peptide receptor; the activation of *OIGC7* by C-ANF and various medaka fish tissue extracts suggests that the extracellular domain of *OIGC7* is structurally similar to that of NPRC, although the residues Ile¹⁸⁸ and Asn²⁰⁵ in the extracellular domain of human NPRC, which are important for modulating hormone specificity (Engel and Lowe, 1995), are not conserved in the extracellular domain of *OIGC7*. It is known that the Japanese eel *Anguilla japonica* contains ANP and CNP and a unique natriuretic peptide, VNP, instead of BNP; it also contains two known natriuretic

peptide receptors, NPR-A (GC-A) and NPR-B (GC-B), and natriuretic peptide clearance receptors (NPR-C and NPR-D) (Takei and Hirose, 2002). These findings led us to the conclusion that in addition to ANP, BNP, and CNP, medaka fish may contain an as of yet unknown ligand, the structure of which is similar to C-ANF and modulate OIGC7.

In the present study using Northern blot analysis, we demonstrated that the 5 kb-*OIGC8* transcript was expressed in the kidney and testis and the 3.3 kb-*OIGC8* transcript was exclusively expressed in the brain (Fig. 8). Moreover, primer extension analysis and RLM-RACE demonstrated that the *OIGC8* gene had two tissue-specific putative transcription initiation sites. A database search revealed that there is no TATA sequence upstream of these two putative transcription initiation sites, although there are several consensus sequences that bind to GATA-1, Cdx-A, and USF upstream of the putative first transcription initiation site and to GATA-1, Cdx-A, and AML-1 upstream of the putative second transcription initiation site. Therefore, we presumed that the *OIGC8* gene has TATA-less promoters above the consensus sequences, and that these promoters may contribute to the regulation of the tissue-specific expression of the *OIGC8* gene; however, an Sp1-binding consensus sequence, which is typical for TATA-less promoters, was not seen upstream of either of the putative transcription initiation sites.

When an *OIGC8* mRNA was transcribed from the second putative transcription initiation site and two introns (17 and 18) remained, the size of the resulting transcript was 3261 bp, which was in good agreement with the results obtained by Northern blot and RNase protection analyses (Figs. 8 and 9B); these results indicated that such transcription and the lack of excision of introns 17 and 18 might occur in the brain. The insertion (or lack of excision) of intron 17 led to the appearance of a new stop codon in the coding region just prior to the catalytic domain, and the resultant mRNA was translated into a protein of 609 amino acids (66.2 kDa) lacking the cyclase catalytic domain. On the other hand, the 5 kb-mRNA for *OIGC8* was formed by transcription from the first transcription initiation site in the kidney and testis, provided the intron excision occurred correctly, and was translated to an active membrane GC of 893 amino acids. Although we are not aware of the biological significance of the *OIGC8* lacking the catalytic domain, this form of *OIGC8* might play a role as a dominant negative protein that inhibits the active form of *OIGC8*.

On the other hand, using RNase protection and RT-PCR analyses on various *OIGC8* mRNAs, we demonstrated several spliced variants of the *OIGC8* gene, in addition to different transcripts such as a 5 kb-mRNA and a 3.3 kb-mRNA. In this study, it was also shown that the major form of splicing in the testis produced a 5 kb-mRNA that was translated to the active form of *OIGC8*; the alternative minor splicing reactions, which occurred in the testis exclusively, produced several spliced variants (shown in Figs. 9A and 9B). The spliced variants lacking half of the 5'-UTR and exon 2 would be translated from different first Met positions

to produce a variety of sizes of proteins containing no putative signal peptide. Since genomic Southern blot analysis showed that a single copy of the *OIGC8* gene was present on the medaka fish genome (Fig. 6), we presumed that the several mRNA species observed here were generated from a single common gene, and that the variety in their 5'-UTR might exert an influence on the degradation of the mRNA (Fen and Daniel, 1991) and/or the various forms might help to differentially compartmentalize the mRNA by allowing it to be translated either immediately or by helping store it for later use (Schmidt and Schiblar, 1995). Thus, it is plausible that the translation of the *OIGC8* mRNA is differentially regulated and that the relative abundance of a particular mRNA species may not be correlated with its translation product. In this regard, it should be mentioned that differences in the 5'-untranslated region have been suggested as exerting an influence on the stability of the mRNA and the efficiency of translation, thereby rendering the post-transcriptional control possible (Griffin *et al.*, 2001). The alternative promoter usage and splicing found in the *OIGC8* gene may thus provide a mechanism for tissue-specific regulation of *OIGC8* gene expression at both the translational and transcriptional level.

Since the *OIGC8* gene and the biological activity of its translation product are very unique in terms of the mode of its transcription and translation in comparison with those of known membrane GCs, one may consider the question of whether the *OIGC8* gene exists only in the medaka fish *O. latipes*, or if this gene also occurs in other species. GenBank Nucleotide Sequence Database search revealed that a 576-bp fragment of human mRNA (XM 095884) similar to a part of extracellular and kinase-like domains of *OIGC8*, although any similar sequences to *OIGC8* were not found in the other species genome database, such as mouse, rat, zebrafish, or mosquito except the fugu database. The Japanese pufferfish *Fugu rubripes* has been used as a model vertebrate because of its minimal genome size of only 400 Mb, which is one-fifth the size of the medaka fish *O. latipes* (Naruse *et al.*, 2000; Wittbrodt *et al.*, 2002; Venkatesh *et al.*, 2000). Recently, the draft sequence data of the whole genome obtained by a whole shotgun genome sequencing program (The Fugu Genome Consortium 2002) in the form of unordered contigs (scaffolds) were made publically available on two web sites, i.e., at the UK HGMP-RC site (<http://fugu.hgmp.mrc.ac.uk>) and at the Ensembl Genome Browser site (<http://www.ensembl.org/>). A database search revealed that fugu genome might possess two *OIGC8* homologs, chr-scaffolds 261 for the whole *OIGC8* protein, chr-scaffolds 10823 for the extracellular domain of *OIGC8*, and chr-scaffolds 5558 for the kinase-like and catalytic domain of *OIGC8*. These results suggest that the existence of the *OIGC8* gene is not restricted to the medaka fish and that its translation product(s) may play an important biological role in general, or else that its product(s) might have played a role in the diversification of a membrane GC gene during gene evolution. In conclusion, *OIGC8* is a novel membrane

GC gene; its transcription and translation products are distinctive and thus future studies on the guanylyl cyclase might reveal its important and tissue-specific functions.

ACKNOWLEDGEMENTS

We are grateful to Ms. Hiroko Kuboshita for tender supporting of this research. We also thank the staff members of the Center for Advanced Science and Technology, Hokkaido University, for the use of their laboratory facilities. This study was supported by a Grant-in-Aid for Scientific Research from the Ministry of Education, Science, Sports, and Culture of Japan (no. 11236202) and by the National Project on Protein Structural and Functional Analyses.

REFERENCES

- Anand-Srivastava MB, Sairam MR, Cantin M (1990) Ring-deleted analogs of atrial natriuretic factor inhibit adenylate cyclase/cAMP system. Possible coupling of clearance atrial natriuretic factor receptors to adenylate cyclase/cAMP signal transduction system. *J Biol Chem* 265: 8566–8572
- Bloch KD, Seidman JG, Naftilan JD, Fallon JT, Seidman CE (1986) Neonatal atria and ventricles secrete atrial natriuretic factor via tissue-specific secretory pathways. *Cell* 47: 695–702
- Chang M-S, Lowe DG, Lewis M, Hellmiss R, Chen E, Goeddel DV (1989) Differential activation by atrial and brain natriuretic peptides of two different receptor guanylate cyclases. *Nature* 341: 68–72
- Chinkers M, Garbers DL (1989) The protein kinase domain of the ANP receptor is required for signaling. *Science* 245: 1392–1394
- Chinkers M, Garbers DL, Chang M-S, Lowe DG, Chin H, Goeddel DV, Schulz S (1989) A membrane form of guanylate cyclase is an atrial natriuretic peptide receptor. *Nature* 338: 78–83
- Chomczynski P, Sacchi N (1987) Single-step method of RNA isolation by acid guanidinium thiocyanate-phenol-chloroform extraction. *Analyt Biochem* 162: 156–159
- Comrie MM, Cutler CP, Cramb G (2001) Cloning and expression of two isoforms of guanylate cyclase C (GC-C) from the European eel (*Anguilla anguilla*). *Comp Biochem Physiol B* 129: 575–586
- Dizhoor AM, Lowe DG, Olsheshevskaya EV, Laura RP, Hurley JB (1994) The human photoreceptor membrane guanylyl cyclase, RetGC, is present in outer segments and is regulated by calcium and a soluble activator. *Neuron* 12: 1345–1352
- Drewett JG, Garbers DL (1994) The family of guanylyl cyclase receptors and their ligands. *Endocrine Rev* 15: 135–162
- Engel AM, Lowe DG (1995) Characterization of the hormone binding site of natriuretic peptide receptor-C. *FEBS Lett* 360: 169–172
- Felsenstein J (1989) PHYLIP-phylogeny interference package (version 3.2). *Cladistics* 5: 164–166
- Fen Z, Daniel TO (1991) 5' Untranslated sequences determine degradative pathway for alternate PDGF B/cis-mRNA's. *Oncogene* 6: 953–959
- Forssmann WG, Richter R, Meyer M (1998) The endocrine heart and natriuretic peptides: histochemistry, cell biology, and functional aspects of the renal urodilatin system. *Histochem. Cell Biol* 110: 335–357
- Frohman MA, Dush MK, Martin GR (1988) Rapid production of full-length cDNAs from rare transcripts: amplification using a single gene-specific oligonucleotide primer. *Proc Natl Acad Sci USA* 85: 8998–9002
- Fülle H-J, Vassar R, Foster DC, Yang R-B, Axel R, Garbers DL (1995) A receptor guanylyl cyclase expressed specifically in olfactory sensory neurons. *Proc Natl Acad Sci USA* 92: 3571–3575
- Füller F, Porter JG, Arfsten AE, Miller J, Schilling JW, Scarborough RM, Lewicki JA, Schenk DB (1988) Atrial natriuretic peptide clearance receptor. Complete sequence and functional expression of cDNA clones. *J Biol Chem* 263: 9395–9401
- Garbers DL, Lowe DG (1994) Guanylyl cyclase receptors. *J Biol Chem* 269: 30741–30744
- Griffin E, Re A, Hamel N, Fu C, Bush H, McCaffrey T, Asch AS (2001) A link between diabetes and atherosclerosis: Glucose regulates expression of CD36 at the level of translation. *Nat Med* 7: 840–846
- Heinemeyer T, Wingender E, Reuter I, Hermjakob H, Kel AE, Kel OV, Ignatieva EV, Ananko EA, Podkolodnaya OA, Kolpakov FA, Podkolodny NL, Kolchanov NA (1998) Databases on transcriptional regulation: TRANSFAC, TRRD and COMPEL. *Nucleic Acids Res* 26: 362–367
- Hisatomi O, Honkawa H, Imanishi Y, Satoh T, Tokunaga F (1999) Three kinds of guanylate cyclase expressed in medaka photoreceptor cells in both retina and pineal organ. *Biochem Biophys Res Co* 255: 216–220
- Itakura M, Iwashina M, Mizuno T, Ito T, Hagiwara H, Hirose S (1994) Mutational analysis of disulfide bridges in the type C atrial natriuretic peptide receptor. *J Biol Chem* 269: 8314–8318
- Iwashina M, Mizuno T, Hirose S, Ito T, Hagiwara H (1994) His¹⁴⁵-Trp¹⁴⁶ residues and the disulfide-linked loops in atrial natriuretic peptide receptors are critical for the ligand-binding activity. *J Biochem* 115: 563–567
- Kimura M (1983) *The Neutral Theory of Molecular Evolution*. Cambridge University Press, Cambridge
- Koesling D, Herz J, Gausepohl H, Niroomand F, Hinsch KD, Mulsch A, Böhme E, Schultz G, Frank R (1988) The primary structure of the 70 kDa subunit of bovine soluble guanylate cyclase. *FEBS Lett* 239: 29–34
- Koesling D, Harteneck C, Humbert P, Bosserhoff A, Frank R, Shultz G, Böhme E (1990) The primary structure of the larger subunit of soluble guanylyl cyclase from bovine lung. Homology between the two subunits of the enzyme. *FEBS Lett* 266: 128–132
- Koller KJ, Lowe DG, Bennett GL, Minamino N, Kangawa K, Matsuo H, Goeddel DV (1991). Selective activation of the B natriuretic peptide receptor by C-type natriuretic peptide (CNP). *Science* 252: 120–123
- Kozak M (1983) Comparison of initiation of protein synthesis in prokaryotes, eucaryotes, and organelles. *Microbiol Rev* 47: 1–45
- Krupinski J, Coussen F, Bakalyar HA, Tang W J, Feinstein PG, Orth K, Slaughter C, Reed RR, Gilman AG (1989) Adenylyl cyclase amino acid sequence: possible channel- or transporter-like structure. *Science* 244: 1558–1564
- Kusakabe R, Kusakabe T, Suzuki N (1999) *In vivo* analysis of two striated muscle actin promoters reveals combinations of multiple regulatory modules required for skeletal and cardiac muscle-specific gene expression. *Int J Dev Biol* 43: 541–554
- Kusakabe T, Suzuki N (2000) The guanylyl cyclase family in medaka fish *Oryzias latipes*. *Zool Sci* 17: 131–140
- Kyte J, Doolittle RF (1982) A simple method for displaying the hydropathic character of a protein. *J Mol Biol* 157: 105–132
- Laemmli UK (1970) Cleavage of structural proteins during the assembly of the head of bacteriophage T4. *Nature* 227: 680–685
- Laura RP, Dizhoor A M, Hurley JB (1996) The membrane guanylyl cyclase, retinal guanylyl cyclase-1, is activated through its intracellular domain. *J Biol Chem* 271: 11646–11651
- Lowe DG, Chang M-S, Hellmiss R, Chen E, Singh S, Garbers DL, Goeddel DV (1989) Human atrial natriuretic peptide receptor defines a new paradigm for second messenger signal transduction. *EMBO J* 8: 1377–1384
- Lowe DG, Dizhoor AM, Liu K, Gu Q, Spencer M, Laura R, Lu L,

- Hurley JB (1995) Cloning and expression of a second photo-receptor-specific membrane retina guanylyl cyclase (RetGC), RetGC-2. *Proc Natl Acad Sci USA* 92: 5535–5539
- Mantoku T, Muramatsu R, Nakauchi M, Yamagami S, Kusakabe T, Suzuki N (1999) Sequence analysis of cDNA and genomic DNA, and mRNA expression of the medaka fish homolog of the mammalian guanylyl cyclase C. *J Biochem* 125: 476–486
- Maruyama K, Sugano S (1994) Oligo-capping: a simple method to replace the cap structure of eukaryotic mRNAs with oligoribonucleotides. *Gene* 138: 171–174
- Matsuda M, Kawato N, Asakawa S, Shimizu N, Nagahama Y, Hamaguchi S, Sakaizumi M, Hori H (2001) Construction of a BAC library derived from the inbred Hd-rR strain of the teleost fish, *Oryzias latipes*. *Genes Genet Syst* 76: 61–63
- Meyer A, Scharl M (1999) Gene and genome duplications in vertebrates: the one-to-four (-to-eight in fish) rule and the evolution of novel gene functions. *Curr Opin Cell Biol* 11: 699–704
- Mount SM (1982) A catalogue of splice junction sequences. *Nucleic Acids Res* 10: 459–472
- Nakane M, Saheki S, Kuno T, Ishii K, Murad F (1988) Molecular cloning of a cDNA coding for 70 kilodalton subunit of soluble guanylate cyclase from rat lung. *Biochem Biophys Res Co* 157: 1139–1147
- Naruse K, Fukamachi S, Mitani, H, Kondo M, Matsuoka T, Kondo S, Hanamura N, Morita Y, Hasegawa K, Nishigaki R, Shimada A, Wada H, Kusakabe T, Suzuki N, Kinoshita M, Kanamori A, Terado T, Kimura H, Nonaka M, Shima A (2000) A detailed linkage map of medaka, *Oryzias latipes*: comparative genomics and genome evolution. *Genetics* 154: 1773–1784
- Potter LR, Garbers DL (1992) Dephosphorylation of the guanylyl cyclase-A receptor causes desensitization. *J Biol Chem* 267: 14531–14534
- Saitou N, Nei M (1987) The neighbor-joining method: a new method for reconstructing phylogenetic trees. *Mol Biol Evol* 4: 406–425
- Sanger R, Nicklen S, Coulson AR (1977) DNA sequencing with chain terminating inhibitors. *Proc Natl Acad Sci USA* 74: 5463–5467
- Schacterle GR, Pollack RL (1973) A simplified method for the quantitative assay of small amount of protein in biologic material. *Analyt Biochem* 51: 654–655
- Schmidt EE, Schiblar U (1995) Cell size regulation, a mechanism that controls cellular RNA accumulation: Consequences on regulation of the ubiquitous transcription factors Oct1 and NF-Y, and the liver-enriched transcription factor DBP. *J Cell Biol* 128: 467–483
- Schulz S, Singh S, Bellet RA, Singh G, Tubb DJ, Chin H, Garbers DL (1989) The primary structure of a plasma membrane guanylate cyclase demonstrates diversity within this new receptor family. *Cell* 58: 1155–1162
- Schulz S, Wedel BJ, Matthews A, Garbers DL (1998) The cloning and expression of a new guanylyl cyclase orphan receptor. *J Biol Chem* 273: 1032–1037
- Seimiya M, Kusakabe T, Suzuki N (1997) Primary structure and differential gene expression of three membrane forms of guanylyl cyclase found in the eye of the teleost *Oryzias latipes*. *J Biol Chem* 272: 23407–23417
- Sharma RK (2002) Evolution of the membrane guanylate cyclase transduction system. *Mol Cell Biochem* 230: 3–30
- Shimizu T, Takeda K, Furuya H, Hoshino K, Nomura K, Suzuki N (1996) A mRNA for membrane form of guanylyl cyclase is expressed exclusively in the testis of the sea urchin *Hemicentrotus pulcherrimus*. *Zool Sci* 13: 285–294
- Shyjan AW, de Sauvage FJ, Gillett NA, Goeddel DV, Lowe DG (1992) Molecular cloning of a retina-specific membrane guanylyl cyclase. *Neuron* 9: 727–737
- Stults JT, O'Connell KL, Garcia C, Wong S, Engel AM, Garbers DL, Lowe DG (1994) The disulfide linkages and glycosylation sites of the human natriuretic peptide receptor-C homodimer. *Biochemistry* 33: 11372–11381
- Sudoh T, Minamino N, Kangawa K, Matsuo H (1990) C-type natriuretic peptide (CNP): a new member of natriuretic peptide family identified in porcine brain. *Biochem Biophys Res Co* 168: 863–870
- Suzuki K, Satoh Y, Kusakabe T, Suzuki N (1999) Molecular phylogenetic analysis of diverse forms of echinoderm guanylyl cyclases. *Zool Sci* 16: 515–527
- Takeda K, Suzuki N (1999) Genomic structure and expression of the medaka fish homolog of the mammalian guanylyl cyclase B. *J Biochem* 126: 104–114
- Takei Y, Hirose S (2002) The natriuretic peptide system in eels: a key endocrine system for euryhalinity? *Am J Physiol-Reg I* 282: R940–R951
- Thompson JD, Higgins DG, Gibson TJ (1994) CLUSTAL W: Improving the sensitivity of progressive multiple sequence alignment through sequence weighting, position-specific gap penalties and weight matrix choice. *Nucleic Acids Res* 22: 4673–4680
- Towbin H, Staehelin T, Gordon J (1979) Electrophoretic transfer of proteins from polyacrylamide gels to nitrocellulose sheets: Procedure and some applications. *Proc Natl Acad Sci USA* 76: 4350–4354
- Wedel BJ, Garbers DL (2001) The guanylyl cyclase family at Y2K. *Annu Rev Physiol* 63: 215–233
- Wedel BJ, Foster DC, Miller DE, Garbers DL (1997) A mutation of the atrial natriuretic peptide (guanylyl cyclase-A) receptor results in a constitutively hyperactive enzyme. *Proc Natl Acad Sci USA* 94: 459–462
- Wittbrodt J, Shima A, Scharl M (2002) Medaka - a model organism from the far East. *Nat Rev Genet* 3: 53–64
- Yamagami S, Suzuki K, Suzuki N (2001) Expression and exon/intron organization of two medaka fish homologs of the mammalian guanylyl cyclase A. *J Biochem* 130: 39–50
- Yang R-B, Foster DC, Garbers DL, Fülle H-J (1995) Two membrane forms of guanylyl cyclase found in the eye. *Proc Natl Acad Sci USA* 92: 602–606
- Venkatesh B, Gilligan P, Brenner S (2000) Fugu: a compact vertebrate reference genome. *FEBS Lett* 476: 3–7
- von Heijne G (1983) Patterns of amino acids near signal-sequence cleavage sites. *Eur J Biochem* 133: 17–21

(Received January 30, 2003 / Accepted February 24, 2003)