



## **Ascidian Actin Genes: Developmental Regulation of Gene Expression and Molecular Evolution**

Author: Kusakabe, Takehiro

Source: Zoological Science, 14(5) : 707-718

Published By: Zoological Society of Japan

URL: <https://doi.org/10.2108/zsj.14.707>

---

BioOne Complete ([complete.BioOne.org](https://complete.BioOne.org)) is a full-text database of 200 subscribed and open-access titles in the biological, ecological, and environmental sciences published by nonprofit societies, associations, museums, institutions, and presses.

Your use of this PDF, the BioOne Complete website, and all posted and associated content indicates your acceptance of BioOne's Terms of Use, available at [www.bioone.org/terms-of-use](https://www.bioone.org/terms-of-use).

Usage of BioOne Complete content is strictly limited to personal, educational, and non - commercial use. Commercial inquiries or rights and permissions requests should be directed to the individual publisher as copyright holder.

---

BioOne sees sustainable scholarly publishing as an inherently collaborative enterprise connecting authors, nonprofit publishers, academic institutions, research libraries, and research funders in the common goal of maximizing access to critical research.

## [REVIEW]

# Ascidian Actin Genes: Developmental Regulation of Gene Expression and Molecular Evolution

Takehiro Kusakabe

*Division of Biological Sciences, Graduate School of Science,  
Hokkaido University, Sapporo 060, Japan*

---

**ABSTRACT**—Actin is a ubiquitous protein in eukaryotic cells and plays an important role in cell structure, cell motility, and the generation of contractile force in both muscle and nonmuscle cells. Multiple genes encoding muscle or nonmuscle actins have been isolated from several species of ascidians and their expression patterns have been investigated. Sequence and expression analyses of muscle actin genes have shown that ascidians have at least two distinct isoforms of muscle actin, the larval muscle and body-wall isoforms. In the ascidian *Halocynthia roretzi*, two clusters of actin genes are expressed in the larval muscle cells. The *HrMA2/4* cluster contains at least five actin genes and the *HrMA1* cluster contains a pair of actin genes whose expression is regulated by a single bidirectional promoter. *cis*-Regulatory elements essential for muscle-specific expression of a larval muscle actin gene *HrMA4a* have been identified. The adult body-wall muscle actin is clearly distinguished from the larval muscle actin by diagnostic amino acids. The adult muscle actin genes may be useful tools to investigate the mechanisms of muscle development in ascidian adults. The evolution of chordate actin genes has been inferred by comparing the organization and sequences of actin genes and performing molecular phylogenetic analysis. The results suggest a close relationship between ascidian and vertebrate actins. The chordate ancestor seems to have evolved the “chordate-type” cytoplasmic and muscle actins before its divergence into vertebrates and urochordates. The phylogenetic analysis also suggests that the vertebrate muscle actin isoforms evolved after the separation of the vertebrates and urochordates. Muscle actin genes have been used to investigate the mechanism of muscle cell regression during the evolution of anural development. The results suggest that the regression of muscle cell differentiation is mediated by changes in the structure of muscle actin genes rather than in the *trans*-acting regulatory factors required for their expression. Actin genes have provided a unique system to study developmental and evolutionary mechanisms in chordates.

---

## 1. INTRODUCTION

Ascidians (subphylum Urochordata, class Ascidiacea) are chordates with a life cycle containing both larval and adult phases (reviewed in Satoh, 1994). Within about a day after fertilization, the ascidian egg develops into a tadpole larva, which consists of approximately 2600 cells. The ascidian tadpole larva exhibits the hallmarks of a chordate, including a motile tail containing a notochord, a dorsal nerve cord, and striated muscle cells. In contrast, the adult ascidian is a sessile organism with little resemblance to other chordates, except for the presence of pharyngeal gill slits and an endostyle, which is considered to be homologous to the vertebrate thyroid gland. Ascidian embryos have been favored for developmental research because they exhibit low cell numbers, contain only a

few different tissue types, develop rapidly, and have a well-known cell lineage (Nishida, 1987; Swalla *et al.*, 1993; Satoh, 1994; Jeffery, 1994; Satoh *et al.*, 1996). Ascidians are also favorable for evolutionary research because of their phylogenetic position near the vertebrates and the radical changes in embryonic development exhibited by certain species (Jeffery and Swalla, 1990, 1992a; Jeffery, 1994; Satoh and Jeffery, 1995).

Actin is a major structural component of the contractile system, both in muscle cells and in nonmuscle cells (Pollard and Cooper, 1986; Sheterline and Sparrow, 1994). Actins are highly conserved proteins found in all eukaryotes from yeast to vertebrates. Most organisms exhibit multiple actin isoforms which are encoded by a small gene family (Sheterline and Sparrow, 1994). Each actin isoform shows a distinct expression pattern specific to a tissue or different developmental stages. In mammals, for example, there are at least four muscle isoforms ( $\alpha$ -skeletal,  $\alpha$ -cardiac,  $\alpha$ -vascular, and  $\gamma$ -enteric)

---

\* Corresponding author: Tel. +81-11-706-3522;  
FAX. +81-11-746-1512.

and two nonmuscle isoforms ( $\beta$ - and  $\gamma$ -cytoplasmic) (Vandekerckhove and Weber, 1979). Because of their widespread distribution among eukaryotes, their highly conserved sequences, and the presence of tissue- and developmental stage-specific isoforms, actin genes have been used as probes to trace the ontogeny and phylogeny of various organisms (Davidson, 1986; Raff *et al.*, 1987; Miwa *et al.*, 1991; Cox and Buckingham, 1992; Jeffery, 1994; Bhattacharya and Stickel, 1994; He and Haymer, 1995; Satoh *et al.*, 1996). Here I describe recent progress in studies of ascidian actin genes and discuss them in the context of evolution and development.

## 2. MUSCLE ACTIN GENES

Ascidians have three types of muscle tissues: larval tail muscle, adult body-wall muscle, and adult heart muscle (for review, see Satoh, 1994). The larval muscle consists of mononuclear striated muscle cells. Adult muscle tissues are morphologically distinguished from the larval muscle. The body wall (mantle) muscle cells are multinucleate smooth muscle cells (Shinohara and Konishi, 1982; Nevitt and Gilly, 1986; Terakado and Obinata, 1987), whereas the heart muscle consists of unicellular striated muscle cells (Kalk, 1970).

Muscle actin cDNA and genomic clones have been iso-

lated from several species of ascidians (Table 1) (Tomlinson *et al.*, 1987; Kusakabe *et al.*, 1991, 1992, 1995, 1996; Beach and Jeffery, 1992; Kovilur *et al.*, 1993; Swalla *et al.*, 1994). Isolation and characterization of cDNA clones from ascidian embryos showed that multiple actin genes are expressed in larval muscle (Kusakabe *et al.*, 1991, 1995; Beach and Jeffery, 1992). cDNA clones for muscle actin were also isolated from adult body-wall libraries (Tomlinson *et al.*, 1987; Kovilur *et al.*, 1993; Swalla *et al.*, 1994). Analysis of sequences and expression patterns of ascidian muscle actin genes has shown that ascidians have at least two distinct muscle actin isoforms, the larval muscle and body-wall isoforms (Kusakabe, 1995; Kusakabe *et al.*, 1997). Little is known about muscle actin genes expressed in adult heart muscle, although they seem to be different from actin genes expressed in the larval tail muscle (Kusakabe, 1995; Kusakabe *et al.*, 1995).

### (i) Organization and expression of larval muscle actin genes

In *Halocynthia roretzi*, at least five muscle actin genes (*HrMA2*, *HrMA4a*, *HrMA4b*, *HrMA5* and *HrMA6*) form a cluster (*HrMA2/4* cluster) in a 30 kb region of genomic DNA (Fig. 1A; Kusakabe *et al.*, 1992). These five genes are aligned in the same direction. The nucleotide sequences of the five

**Table 1.** Actin genes identified in ascidians

Type	Species	Genes	Libraries	References
Larval muscle	<i>Halocynthia roretzi</i>	<i>HrMA2</i> , <i>HrMA4a</i> , <i>HrMA4b</i> , <i>HrMA5</i> , <i>HrMA6</i>	cDNA, genomic	Kusakabe <i>et al.</i> (1991) Kusakabe <i>et al.</i> (1992)
		<i>HrMA1a</i> , <i>HrMA1b</i>	cDNA, genomic	Kusakabe <i>et al.</i> (1995)
	<i>Styela clava</i>	<i>ScTb1</i> , <i>ScTb24</i> , <i>ScTb30</i> , <i>ScTb12/24</i>	cDNA	Beach and Jeffery (1992)
	<i>Molgula oculata</i>	<i>MocuMA1</i>	genomic	Kusakabe <i>et al.</i> (1996)
	<i>Molgula occulta</i>	<i>MoccMA1a</i> (pseudogene), <i>MoccMA1b</i> (pseudogene)	genomic	Kusakabe <i>et al.</i> (1996)
Adult muscle (body wall)	<i>Styela plicata</i>	<i>SpMA1</i>	cDNA	Tomlinson <i>et al.</i> (1987) Kovilur <i>et al.</i> (1993)
	<i>Molgula citrina</i>	<i>McMA1</i>	cDNA	Swalla <i>et al.</i> (1994)
	<i>Molgula oculata</i>	<i>MocuMA1</i>	genomic	Kusakabe <i>et al.</i> (1997)
Nonmuscle (cytoplasmic)	<i>Styela clava</i>	<i>ScCA15</i>	cDNA	Beach and Jeffery (1990)
	<i>Styela plicata</i>	<i>SpCA8</i>	cDNA	Kovilur <i>et al.</i> (1993)
	<i>Halocynthia roretzi</i>	<i>HrCA1</i>	cDNA, genomic	Araki <i>et al.</i> (1996) Kusakabe <i>et al.</i> (1997)

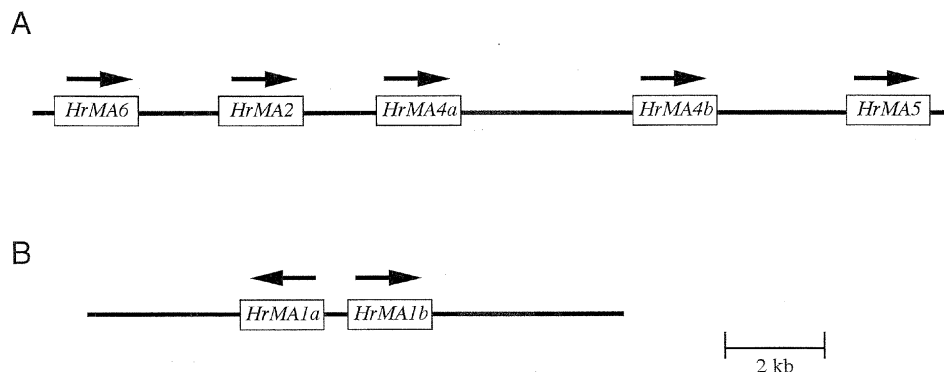

**Fig. 1.** Organization of the *H. roretzi* larval muscle actin gene clusters (Kusakabe *et al.*, 1992, 1995). (A) The *HrMA2/4* cluster. (B) The *HrMA1* pair. Arrows indicate the orientation of coding region of actin genes.

*HrMA2/4* cluster genes, including their 5' flanking regions are highly conserved, suggesting that the expression of these genes is controlled coordinately (Kusakabe *et al.*, 1992). Microinjection of fusion gene constructs in which the 5' flanking region of each *HrMA2/4* cluster gene is fused with *lacZ* gene into *H. roretzi* embryos suggests that these genes are coexpressed in larval muscle cells of *H. roretzi* embryos (Kusakabe *et al.*, 1995). None of the *HrMA2/4* cluster genes are expressed in body wall muscle and heart muscle of mature adults (Kusakabe, 1995).

The *HrMA4a* gene is the most extensively studied gene in the *HrMA2/4* cluster. *HrMA4a* transcripts first appear in B6.2 (the progenitor of B7.4) at the 32-cell stage, in B7.8 at the 64-cell stage, and in B7.5 around the 76-cell stage, respectively, suggesting that the transcription of this gene is initiated prior to developmental fate restriction in the B7.4-sublineage (Satou *et al.*, 1995). *HrMA4* expression is restricted to developing muscle cells and transcripts accumulate as development proceeds (Kusakabe *et al.*, 1991; Satou *et al.*, 1995) (Fig. 2). Promoter function of the *HrMA4a* gene has been analyzed in detail, and *cis*-regulatory sequences required for the muscle-specific gene expression have been identified (Hikosaka *et al.*, 1994; Satou and Satoh, 1996; see below).

The *H. roretzi* genome contains another cluster of muscle actin genes (*HrMA1* pair) in which the *HrMA1a* and *HrMA1b* are closely linked in a head-to-head arrangement on opposite DNA strands and share a 340-bp 5' flanking sequence (Fig. 1B; Kusakabe *et al.*, 1995). The nucleotide sequences of *HrMA1a* and *HrMA1b*, including their first introns, are quite similar to each other, although the 3' half of *HrMA1b* has not been isolated. Examination of the promoter function of the *HrMA1* pair revealed that they share promoter activity and are coexpressed in larval muscle cells (Kusakabe *et al.*, 1995; Satoh *et al.*, 1996). *HrMA1* transcripts were first detected at

the 64-cell stage (Satoh *et al.*, 1996). The tandem cluster of *HrMA2/4* genes and the bidirectional promoter of the *HrMA1* pair could expedite utilization of muscle-specific *trans*-acting factors. The organization of larval-muscle actin genes in the genome may play an important role in the synthesis of a large amount of actins during the process of rapid differentiation of the muscle cells (Kusakabe *et al.*, 1995).

Expression of multiple muscle actin genes encoding similar or identical proteins in larval muscle cells seems to be a common feature in ascidians. In *Styela clava*, at least four different muscle actin genes (*ScTb1*, *ScTb24*, *ScTb30*, and *ScTb12/34*) encoding the same actin isoform are expressed in the larval tail muscle cells (Beach and Jeffery, 1992). These muscle actin genes are expressed in different temporal and spatial expression patterns during development. *ScTb1* transcripts were detected in eggs at very low level and disappear shortly after fertilization. On the other hand, maternal mRNA of *ScTb12/34*, *24*, *30* was not detected. Zygotic transcription of *ScTb* genes first appears during gastrulation, and transcripts gradually accumulate during subsequent neurulation and muscle cell differentiation. *ScTb24* is expressed primarily in tail muscle cells of the developing tailbud embryos, whereas *ScTb1* is expressed in a variety types of cells, including the muscle, mesenchyme, epidermal, and neural cells.

In contrast to the *H. roretzi* larval muscle actin genes, some of the *ScTb* genes (*ScTb1*, *12*, *24*) are also expressed in adults (Beach and Jeffery, 1992). *In situ* hybridization analysis showed that *ScTb24* transcripts were most abundant in vascular tissues (blood sinuses) of the body wall and branchial sac; much lower level of transcripts were detected in body-wall muscle cells (Beach and Jeffery, 1992). On the other hand, *ScTb30* expression was only detected in embryos (Beach and Jeffery, 1992).

**(ii) Transcriptional regulation of larval muscle actin genes**

**HrMA4a gene.** The 5' flanking sequences of the five *HrMA2/4* cluster genes resemble each other. As shown in Fig. 3A, the 5' upstream region close to the transcription start site of *HrMA4a* contains several consensus sequences, which include a TATA box at -30, an E-box at -71, a CArG box at -116, and a cluster of three E-boxes between -150 and -190 (Kusakabe *et al.*, 1992).

Promoter function of an ascidian muscle actin gene was first investigated by microinjection of p*HrMA4a*CAT, a recombinant plasmid in which about 1.4 kb of the 5' upstream region of *HrMA4a* had been fused with the bacterial chloramphenicol acetyltransferase gene (*CAT*). When p*HrMA4a*CAT was introduced into *H. roretzi* fertilized eggs and the appearance of CAT protein was examined later by the anti-CAT antibody, CAT expression was restricted to muscle cells of the larval tail (Hikosaka *et al.*, 1992). Specific promoter function of the 1.4 kb upstream region was further confirmed by microinjection of another fusion gene construct, p*HrMA4a*-Z, in which the same upstream region was fused with the coding sequence of a bacterial  $\beta$ -galactosidase (*lacZ*) gene. When this construct was introduced into fertilized eggs and the *lacZ* expres-

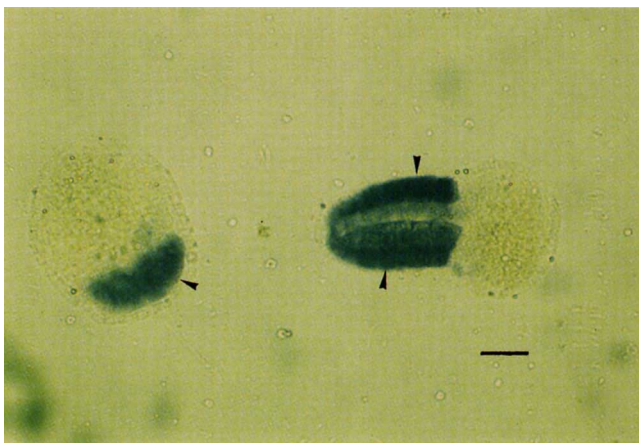

**Fig. 2.** Whole-mount *in situ* hybridization with a digoxigenin-labeled antisense RNA probe showing the accumulation of *HrMA2/4* mRNA in a neurula (left) and a tailbud embryo (right) of *Halocynthia roretzi* (Kusakabe, 1995). Hybridization signals are restricted to presumptive muscle cells in the embryo (arrowheads). All the muscle cells, originating from primary and secondary lineages (Nishida, 1987), are stained. Scale bar: 50  $\mu$ m.

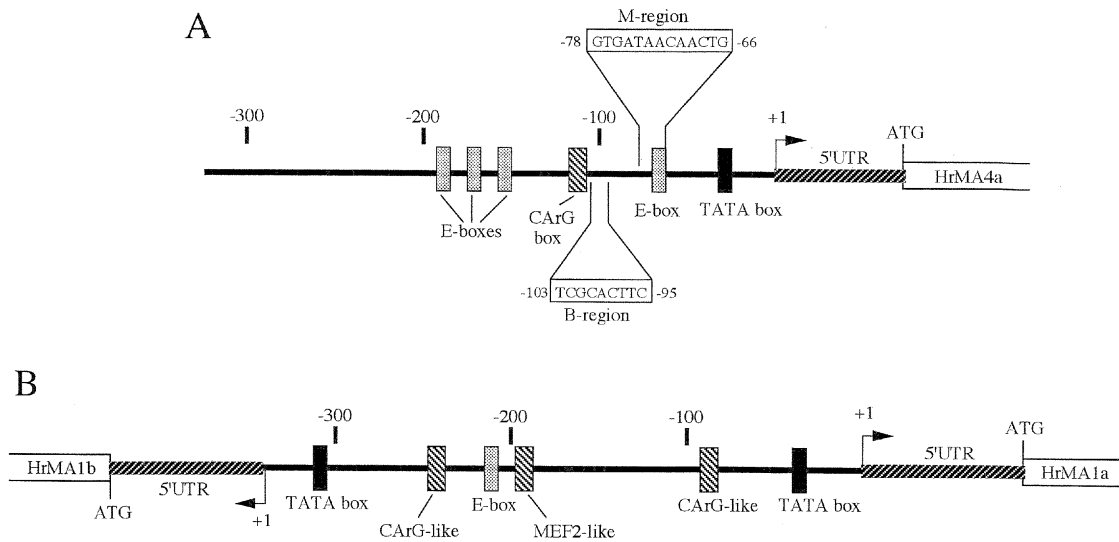

**Fig. 3.** Diagrammatic representation of promoter structure of the *HrMA4a* gene (A) and *HrMA1* genes (B). Numbers indicate nucleotide positions relative to the transcription initiation site (+1) of *HrMA4a* (A) or *HrMA1a* (B). Conserved motifs, including TATA box, E-box, CArG box, and MEF2-binding-site-like sequences, are indicated by boxes (Kusakabe *et al.*, 1992, 1995). Two sequences, "B-region" and "M-region", essential to the muscle-specificity of *HrMA4a* promoter are shown in A (Satou and Satoh, 1996).

sion was examined by histochemical detection of the enzyme activity, expression was present in larval muscle cells (Fig. 4A) (Hikosaka *et al.*, 1993, 1994).

Deletion constructs of the 5' upstream region of *HrMA4a* fused with *lacZ* were microinjected into *H. roretzi* fertilized eggs. No changes in the level or tissue specificity of expression were evident when the upstream sequence was deleted down to -103, suggesting that the 103-bp upstream region is sufficient for appropriate spatial expression of the gene (Hikosaka *et al.*, 1994). However, the reporter gene was not expressed in muscle cells when a 72-bp upstream region was used in the assay (Hikosaka *et al.*, 1994). Satou and Satoh (1996) further narrowed down the 5'-flanking region of *HrMA4a* required for muscle-specific expression by an exhaustive analysis. They analyzed expression of promoter-*lacZ* fusion constructs containing a series of 3'-deletions of the promoter, a mutated proximal promoter, or a partial SV40 promoter sequence in place of *HrMA4a* proximal promoter sequence. The results demonstrated that the 38-bp long sequence between -66 and -103 is sufficient for the muscle-specific expression of the gene (Satou and Satoh, 1996). Within this 38-bp region, two short sequences, 5'-TCGCACTTC-3' and 5'-GTGATAACAACCTG-3', were shown to be essential to the muscle-specificity of *HrMA4a* promoter by analyzing a series of mutation constructs in which two- or three-base substitutions were introduced into the 38-bp region (Fig. 3A) (Satou and Satoh, 1996).

The reporter gene was also expressed in larval muscle cells when p*HrMA4a*-Z was injected into *Ciona savignyi* eggs (Hikosaka *et al.*, 1993; see Fig. 4B). *Ciona* and *Halocynthia* are representative of the two major subgroup of ascidians, and the genetic circuitry underlying muscle differentiation seems to be conserved between the two species. This may

be a great advantage to study mechanisms of muscle cell differentiation of ascidian embryos since muscle determinants have been investigated using *Ciona* (Nishikata *et al.*, 1987; Marikawa *et al.*, 1994, 1995), while *Halocynthia* embryos have been used to study control mechanisms of muscle-specific gene expression (Hikosaka *et al.*, 1994; Araki *et al.*, 1994; Kusakabe *et al.*, 1995; Satou *et al.*, 1995; Satou and Satoh, 1996; Araki and Satoh, 1996; Satoh *et al.*, 1996).

Myogenic regulatory genes, *MyoD*, *myogenin*, *Myf-5*, and *MRF-4*, are essential for vertebrate myogenesis (Hasty *et al.*, 1993; Rawls *et al.*, 1995). They encode transcription factors that belong to the basic helix-loop-helix (bHLH) protein family. These myogenic bHLH proteins bind to the E-box motif (CANNTG) as heterodimers with E2A proteins (Lassar *et al.*, 1991). The *AMD1* gene, encoding an ascidian homolog of vertebrate myogenic bHLH proteins, was isolated and characterized (Araki *et al.*, 1994). Zygotic expression of *AMD1* begins at the 64-cell stage and was confined to the muscle lineage cells during embryogenesis (Satoh *et al.*, 1996). There is an E-box sequence at -71 of *HrMA4a* (Fig. 3A). We examined the significance of this motif for muscle-specific expression of the reporter gene. Mutations in the proximal E-box sequence did not diminish the muscle-specific expression of the reporter gene, although frequency of embryos with  $\beta$ -galactosidase activity decreased to about two-thirds of the control (Hikosaka *et al.*, 1994). Therefore, it is unlikely that *AMD1* is required for and is closely associated with muscle-specific expression of *HrMA4a*. However, *AMD1* may indirectly regulate *HrMA4a* expression via interaction with other DNA-binding factors and maintain the differentiation state by enhancing the expression of muscle-specific differentiation genes.



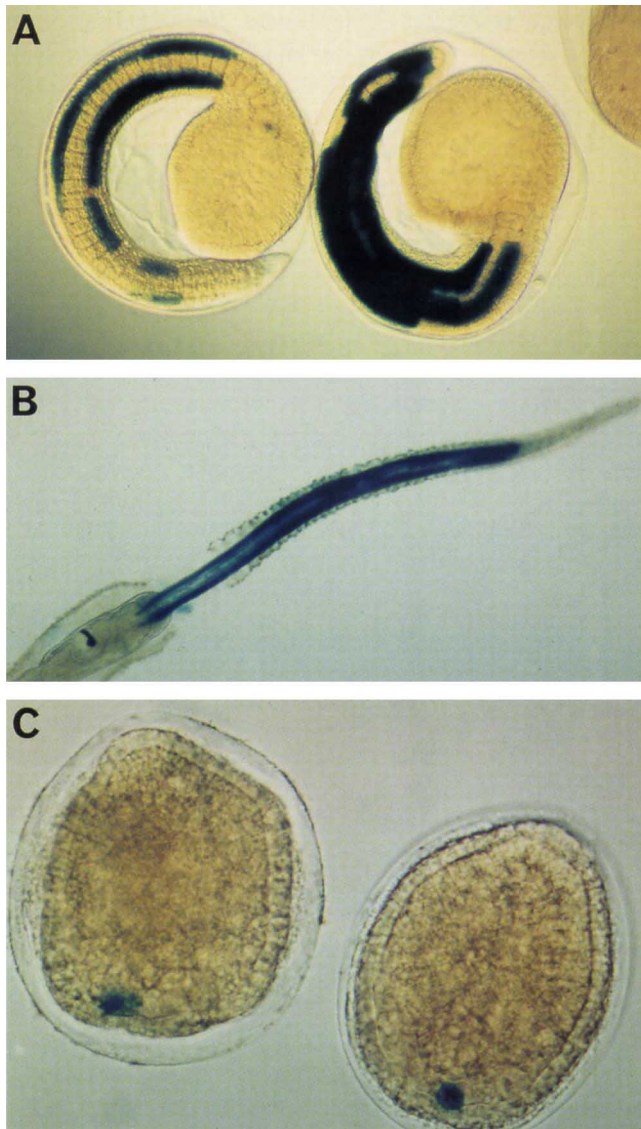

**Fig. 4.** Expression of *lacZ* gene in ascidian embryos that developed from eggs injected with actin promoter-*lacZ* fusion gene constructs. **(A)** Tailbud stage embryos of *H. roretzi* developed from eggs injected with a promoter-*lacZ* fusion construct of the *H. roretzi* muscle actin gene *HrMA1b*. *lacZ* is expressed in the tail muscle cells. **(B)** A tadpole larva of *Ciona intestinalis* developed from eggs injected with *lacZ* gene under control of an *M. oculata* muscle actin gene promoter.  $\beta$ -Gal activity was observed in the tail muscle cells. **(C)** Anural larvae of *Molgula occulta* developed from eggs injected with *lacZ* gene under control of an *M. oculata* muscle actin gene promoter.  $\beta$ -Gal activity was observed in some of the vestigial muscle cells.

**HrMA1a and HrMA1b genes.** As shown in Fig. 3B, the transcription initiation sites of *HrMA1a* and *HrMA1b* genes are only 340-bp apart and a TATA box is located at -30 in each promoter (Kusakabe *et al.*, 1995). Nucleotide sequences of the 5' untranslated region and untranscribed region up to the TATA boxes are highly conserved between the two genes, whereas the nucleotide sequence between the two TATA boxes showed no distinct symmetry except for the presence of two CARG box-like sequences (Minty and Kedes, 1986)

around position -80 (Fig. 3B). One E-box sequence and one MEF2 binding site (Gossett *et al.*, 1989) are located in the middle of the 5' flanking region of the genes (Fig. 3B). When constructs in which the shared upstream region of *HrMA1* pair was fused with *lacZ* in either direction were microinjected into eggs, the reporter gene was expressed in muscle cells of the larval tail, suggesting a bidirectional promoter that regulates muscle-specific transcription of the *HrMA1* pair (Kusakabe *et al.*, 1995). Mutations in the E-box sequence did not diminish the muscle specific expression of the reporter gene, although the frequency of embryos with  $\beta$ -galactosidase activity decreased to some extent (Satoh *et al.*, 1996). Therefore, as in the case of the clustered actin-genes, it is unlikely that AMD1 is required for muscle-specific expression of *HrMA1a* and *HrMA1b* (Satoh *et al.*, 1996).

The promoter activity of deletion constructs of *HrMA1a* and *HrMA1b* was also examined (Satoh *et al.*, 1996). Deletion constructs of the 190-bp upstream region of *HrMA1a* and of the 139-bp upstream region of *HrMA1b* lack the MEF2 binding site (Fig. 3B). When these deletion constructs were microinjected into fertilized eggs, the reporter gene was expressed in muscle cells of tailbud embryos. Deletion constructs of the 85-bp upstream region of *HrMA1a* and of the 89-bp upstream region of *HrMA1b* lack the CARG box-like binding site (Fig. 3B). When these deletion constructs were microinjected into fertilized eggs, the reporter gene expression was not detected in most of the injected embryos. Therefore, it is likely that rather short sequences including CARG box-like sequence are essential for the muscle-specific expression of *HrMA1a* and *HrMA1b* (Satoh *et al.*, 1996).

**(iii) Actin genes expressed in adult muscle**

As described above, neither the *HrMA2/4* cluster genes nor the *HrMA1* genes are expressed in body-wall muscle and heart muscle of *H. roretzi* mature adult (Kusakabe, 1995; Kusakabe *et al.*, 1995). The adult muscle tissues seem to express actin genes different from those expressed in larval muscle (Kusakabe, 1995). Muscle actin genes distinct from those expressed in larval muscle cells have been identified from *Styela plicata* and *Molgula citrina* adult body-wall cDNA libraries and a *Molgula oculata* genomic library (Tomlinson *et al.*, 1987b; Kovilur *et al.*, 1993; Swalla *et al.*, 1994; Kusakabe *et al.*, 1997) (Table 1). These genes are expressed in adult body-wall muscle but not in larval tail muscle (Jeffery *et al.*, 1990; Swalla *et al.*, 1994).

The temporal and spatial expression patterns of the adult muscle actin genes were investigated during postembryonic development of several ascidian species, including *S. plicata*, *M. citrina*, *M. oculata*, and *Molgula occulta* (Jeffery *et al.*, 1990; Swalla *et al.*, 1994). In *S. plicata*, *M. oculata*, and *M. occulta*, which are oviparous species, expression of the adult muscle actin gene begins after the larva settles on a substrate and begins metamorphosis (Jeffery *et al.*, 1990). On the other hand, in *M. citrina*, which is an ovoviviparous species, the expression of adult muscle actin gene *McMA1* was first detected exclusively in the mesenchyme cells of the late tailbud em-

bryos. The *McMA1* transcripts persist in mesenchyme cells after metamorphosis. Thus, the adult muscle actin gene shows a heterochronic shift of expression into the larval phase in *M. citrina* (Jeffery *et al.*, 1990; Swalla *et al.*, 1994). *M. citrina* has evolved adulation (Jägersten, 1972), in which development of the branchial sac, siphons, and heart is shifted into the larval phase (Grave, 1926). Thus, the heterochronic expression of *McMA1* accompanies adulation in *M. citrina* (Jeffery *et al.*, 1990; Swalla *et al.*, 1994).

In *H. roretzi*, some larval muscle actin genes are expressed in trunk ventral cells, which are derived from B7.5 blastomeres of the 64-cell stage embryo (Nishida, 1987; Kusakabe *et al.*, 1995; Y. Satou *et al.*, unpublished data). A recent cell-lineage study has shown that the trunk ventral cell is a progenitor of adult body-wall and heart muscle cells (Hirano and Nishida, personal communication). Therefore, the larval muscle actins may also be a component of body-wall and heart myofibrils in the early stages of adult development. The expression patterns of muscle actin genes during adult muscle development are still largely unknown. Future studies on muscle actin gene expression during adult development would provide important information to help understand development of body wall and heart muscles as well as their evolutionary relationship with vertebrate musculature.

### 3. NONMUSCLE ACTIN GENES

Actin genes expressed in nonmuscle cells encode isoforms different from those in muscle cells (Sheterline and Sparrow, 1994). cDNAs coding for nonmuscle actin (cytoplasmic or cytoskeletal actin) have been isolated from the ascidians *S. plicata*, *S. clava*, and *H. roretzi* (Beach and Jeffery, 1990; Kovilur *et al.*, 1993; Araki *et al.*, 1996) (Table 1). *ScCA15* is a cDNA clone encoding a cytoplasmic actin of *S. clava* (Beach and Jeffery, 1990). The *ScCA15* transcripts are present in eggs and cleaving embryos and disappear before gastrulation. Zygotic *ScCA15* mRNA accumulation begins after neurulation and continues during tail formation. *In situ* hybridization shows that the zygotic transcripts accumulate primarily in epidermis and neural tube (Beach and Jeffery, 1990). These tissues continue to divide after cell division has ceased in other embryonic cells. The *ScCA15* is also expressed in specific tissues of the adult: notably the digestive tract and the germinal layers of the testis and ovary, each of which also contains populations of rapidly dividing cells (Ermak, 1975, 1976). Thus, the *ScCA15* actin may function in cell proliferation (Beach and Jeffery, 1990). A cDNA clone *SpCA8* was isolated from an *S. plicata* body-wall library and encodes a cytoplasmic actin resembling *ScCA15* (Kovilur *et al.*, 1993). The expression patterns of *SpCA8* have not been reported to date.

In *H. roretzi*, the expression patterns of a cytoplasmic actin gene (*HrCA1*) have been investigated by northern and *in situ* hybridizations (Araki *et al.*, 1996). As in the case of *ScCA15*, *HrCA1* transcripts are present in eggs and disappear after fertilization. The zygotic expression of *HrCA1* begins at the late gastrula stage. The first sign of expression

was detected in primordial muscle cells. Weak expression was then observed in notochord cells and this expression continued to be present up to the hatching stage. At the neural-plate and later stages, *HrCA1* is expressed predominantly in mesenchyme cells and some neuronal cells. In addition, cleavage-arrested embryos exhibited *HrCA1* expression only in mesenchyme-cell lineages. Therefore, *HrCA1* expression may be used as molecular marker for monitoring the differentiation of mesenchyme cells (Araki *et al.*, 1996). In adults, *HrCA1* expression was found in every tissue examined, including the gill, body-wall muscle, gonad, digestive gland, and intestine. The expression patterns of *HrCA1* are different from those of *ScCA15* (Beach and Jeffery, 1990; Araki *et al.*, 1996). The deduced amino acid sequences are also considerably different between *HrCA1* and *ScCA15* (Kusakabe *et al.*, 1997). Ascidians probably have at least two types of nonmuscle actins whose sequence and expression patterns are different from each other (Araki *et al.*, 1996; Kusakabe *et al.*, 1997).

## 4. ACTIN GENES AND CHORDATE EVOLUTION

### (i) Phylogenetic analysis of chordate actins

To investigate the origin and evolution of chordate actin isoforms, the sequences and exon-intron organization of ascidian actin genes were compared with those of other invertebrate and vertebrate actin genes (Kovilur *et al.*, 1993; Kusakabe, 1995; Kusakabe *et al.*, 1997). Sequence comparisons and molecular phylogenetic analyses suggested a close relationship between the ascidian and vertebrate actin isoforms (Kovilur *et al.*, 1993; Kusakabe *et al.*, 1997). In vertebrates, the muscle actin is clearly distinguished from the nonmuscle actin by about 20 diagnostic amino acid positions (Vandekerckhove and Weber, 1978, 1979). On the other hand, nonchordate-invertebrate muscle actins, including echinoderm, arthropod, nematode actins, are much more similar to the vertebrate cytoplasmic actin than to the vertebrate muscle actin (Vandekerckhove and Weber, 1984). As shown in Figs. 5 and 6, ascidian muscle actins are distinguished by diagnostic amino acids and group with the vertebrate muscle actins in the phylogenetic tree. Similarly, the ascidian cytoplasmic actin *SpCA8* is similar to the vertebrate cytoplasmic actin (Figs. 5 and 6; Kovilur *et al.*, 1993; Kusakabe *et al.*, 1997). The chordate ancestor seems to have evolved the "chordate-type" cytoplasmic and muscle actins before its divergence into vertebrates and urochordates.

The chordate muscle actin clade consisted of three branches, each supported by relatively high bootstrap values (Fig. 5). One of the branches contained the vertebrate muscle actins and the other two branches contained the ascidian larval and ascidian body-wall muscle actins. The presence of two distinct lineages of ascidian muscle actins is consistent with our findings that the larval and adult muscle actins are distinguished by diagnostic amino acids (Kusakabe, 1995). The molecular phylogenetic trees indicated that the ascidian larval muscle actin is more closely related to the vertebrate muscle actin than the ascidian adult actin (Fig. 5; Kusakabe

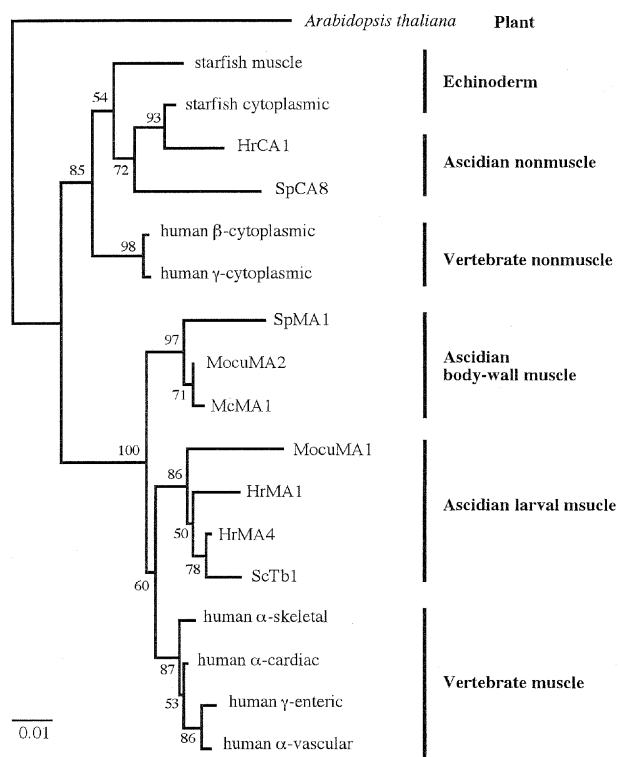

**Fig. 5.** Molecular phylogenetic analysis of deuterostome actins (Kusakabe *et al.*, 1997). A phylogenetic tree was inferred by the neighbor-joining method (Saitou and Nei, 1987). A plant actin (*Arabidopsis thaliana* AAc1) was included as the outgroup. Branch length are proportional to evolutionary distances. Scale bar indicates an evolutionary distances of 0.01 amino acid substitution per position in the sequence. Numbers are percentages of 1,000 bootstrap replicates in which the same internal branch was recovered (Felsenstein, 1985). Accession numbers for actin sequences are: M20543, human  $\alpha$ -skeletal muscle actin; J00073, human  $\alpha$ -cardiac muscle actin; X13839, human  $\alpha$ -vascular smooth muscle actin; X16940, human  $\gamma$ -enteric smooth muscle actin; M10277, human  $\beta$ -cytoplasmic actin; M19283, human  $\gamma$ -cytoplasmic actin; X61042, SpMA1; L21915, McMA1; D10887, HrMA4; D29014, HrMA1; D78190, MocuMA1; X61040, ScTb1; X61041, SpCA8; M26500, starfish (*Pisaster ochraceus*) muscle actin; M26501, starfish (*P. ochraceus*) cytoplasmic actin; M20016, *A. thaliana* AAc1.

*et al.*, 1997). This suggests that the chordate ancestor had at least two muscle actin isoforms: the ancestral adult-muscle actin and ancestral vertebrate/larval muscle actin. However, an alternative possibility is that the adult isoform appeared in the urochordate lineage after the vertebrate lineage diverged and that the ancestral adult actin evolved rapidly.

The molecular phylogenetic analyses showed that the four muscle actin isoforms in vertebrates ( $\alpha$ -skeletal,  $\alpha$ -cardiac,  $\alpha$ -vascular, and  $\gamma$ -enteric) are more closely related to each other than to the ascidian isoforms (Fig. 5; Kusakabe *et al.*, 1997). Similarly, the  $\beta$ - and  $\gamma$ -cytoplasmic actins of vertebrates show a closer relationship to each other than to the ascidian and echinoderm nonmuscle isoforms (Fig. 5). These results suggested that the vertebrate actin gene family was established by the duplication of one ancestral muscle actin gene and one ancestral cytoplasmic actin gene after the divergence

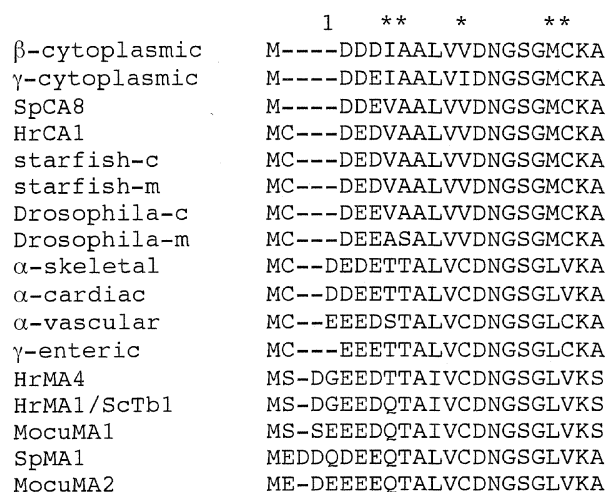

**Fig. 6.** Alignment of the amino acid sequences of amino-terminal regions of various animal actins. Amino-terminal sequences of eight ascidian actins (HrMA4, HrMA1, ScTb1, MocuMA1, MocuMA2, SpMA1, HrCA1, and SpCA8), two echinoderm actins (starfish-c, *Pisaster ochraceus* cytoplasmic actin; starfish-m, *P. ochraceus* muscle actin), six human actins, and two *Drosophila melanogaster* actins (Drosophila-c, cytoplasmic actin 5C; Drosophila-m, muscle actin 79B; accession numbers K00667 and M18829, respectively) are compared. Amino acids are indicated with one-letter codes. Dashes indicate gaps introduced in the sequences to optimize the alignment. Diagnostic amino acid positions that distinguish the vertebrate  $\alpha$ -striated muscle actin from the vertebrate  $\beta$ -cytoplasmic actin are indicated by asterisks (Vandekerckhove and Weber, 1978, 1979). The numbering of the amino acid residues is according to Vandekerckhove and Weber (1984).

of the vertebrate and urochordate lineages (Kusakabe *et al.*, 1997). The diversification of multigene families is thought to have played an important role during vertebrate evolution (Miyata *et al.*, 1994; Iwabe *et al.*, 1996) and may have coincided with the evolution of the complex vertebrate body plan.

The length and sequence of the amino-terminal regions are highly variable among actin isoforms and in different species (Fig. 6). While vertebrate muscle actins and most invertebrate actins have a Met-Cys sequence followed by a cluster of acidic amino acids (Glu and/or Asp), the vertebrate cytoplasmic actins lack a Cys residue next to the first Met. The comparison of the amino-terminal sequences and molecular phylogenetic analyses showed that the HrCA1 cytoplasmic actin is closely related to the echinoderm cytoplasmic actin. In contrast the SpCA8 cytoplasmic actin is more distantly related to the echinoderm cytoplasmic actin, and its amino-terminal sequence is similar to that of the vertebrate cytoplasmic actins and lacks a Cys residue next to the first Met. These results suggest that at least two types of nonmuscle actins are present in ascidians. Multiple nonmuscle actin genes in ascidians were suggested by genomic Southern hybridization (Beach and Jeffery, 1990) and the expression pattern of a cytoplasmic actin gene (Beach and Jeffery, 1990; Araki *et al.*, 1996). Since a vertebrate-type cytoplasmic actin lacking a Cys residue in the amino-terminal region has not been reported in echinoderms, the vertebrate-type cytoplasmic actin



genes may have arisen from an ancestral actin gene by losing the Cys residue (Kusakabe *et al.*, 1997).

### (ii) Exon-intron organization

The positions of introns in ascidian muscle actin genes were shown to be identical to those of vertebrate muscle actin genes (Kusakabe *et al.*, 1992, 1995, 1997). However, the number of introns in the ascidian larval muscle actin genes is smaller than that in other deuterostome actin genes. An extreme case is the *M. oculata* muscle actin gene *MocuMA1*, which contains no introns (Kusakabe *et al.*, 1996). The primitive situation in deuterostomes, however, seems to be muscle actin genes with introns. The ascidian larval muscle actin genes may have lost their introns to expedite the processing and cytoplasmic accumulation during the relatively short interval of muscle cell differentiation during larval development (Kusakabe *et al.*, 1996).

Six intron positions (41/42, 121/122, 150, 204, 268, 328/329) are present in both muscle and nonmuscle actin genes in deuterostomes, but they are not conserved in protostomes (Kusakabe *et al.*, 1997). The ancestral deuterostome may have had a single prototypic actin gene that contained six or more introns. Since the number of introns varies from zero to seven in the extant deuterostome actin genes, different introns seem to have been lost during the evolution of each lineage. The conservation of intron positions in both the deuterostome cytoplasmic and muscle actin genes suggests that the ancestral vertebrate-type muscle actin gene appeared early during chordate evolution, and its characteristic amino acid sequence was established in a relatively short time.

The intron at position 308 in the *HrCA1* cytoplasmic actin gene is unique among deuterostome actin genes but is also present in *Drosophila melanogaster* muscle actin genes 79B and 88F (Fyrberg *et al.*, 1981; Kusakabe *et al.*, 1997). Common intron positions of distantly related species are known for plant and vertebrate-muscle actin genes (position 150) and for plant actin genes and a *Caenorhabditis elegans* actin gene (position 18/19). The presence of these conserved intron positions supports the hypothesis that the ancient eukaryotic actin gene had a large number of introns (Doolittle, 1978; Kusakabe *et al.*, 1997).

## 5. EVOLUTIONARY CHANGES IN MUSCLE ACTIN GENES IN ANURAL ASCIDIANS

### (i) Anural (tailless) development of ascidians

Most ascidian species show indirect development in which the embryo develops into a tadpole larva. The tailed (or urodele) larva consists of a head, containing a brain with a neural sensory organ(s), and a tail, containing a notochord and flanking bands of striated muscle cells (Katz, 1983). The larval tail is formed by coordinated morphogenetic movements and differentiation of the prospective notochord, muscle, and posterior epidermal cells (Swalla, 1993; Satoh, 1994). Anural development is an alternate mode of development in which the embryo develops into a tailless (or anural) larva (reviewed

in Jeffery and Swalla, 1990). Anural embryos lack typical urodele larval features, including the neural sensory organ, notochord, and differentiated muscle cells. Fewer than 20 ascidian species have been described with anural development, and most of these species are classified in the family Molgulidae (Berrill, 1931; Jeffery and Swalla, 1990). Urodele development is thought to be ancestral in ascidians, a viewpoint supported by the expression of vestigial urodele features in some anural species (Berrill, 1931; Whittaker, 1979; Swalla and Jeffery, 1990, 1992; Bates and Mallett, 1991) and molecular phylogenetic analysis (Hadfield *et al.*, 1995).

The mechanisms underlying the transition from urodele to anural development have been investigated in the closely related ascidians *M. oculata*, which has a urodele larva, and *M. occulta*, which has an anural larva (Swalla and Jeffery, 1990, 1996; Jeffery and Swalla, 1991; Swalla *et al.*, 1993; Kusakabe *et al.*, 1996). *M. occulta* produces notochord and muscle precursor cells but they remain undifferentiated in the posterior region of the larva. The ancestral urodele features, including the neural sensory organ, the notochord, and some aspects of muscle cell differentiation, are restored in interspecific hybrids produced by fertilization of *M. occulta* eggs with *M. oculata* sperm (Swalla and Jeffery, 1990; Jeffery and Swalla, 1991, 1992b). The restoration of urodele features in hybrid larvae suggests that anural development is mediated by loss-of-function mutations in zygotic genes. Recently, the *uro* genes, which encode potential regulatory factors expressed in *M. oculata* but not in *M. occulta*, have been identified and characterized (Swalla *et al.*, 1993). The *uro* gene *Manx*, which encodes a zinc finger protein, is required for restoration of urodele features in hybrid embryos and may play an important role in the specification of the chordate body plan (Swalla and Jeffery, 1996).

### (ii) Muscle actin gene expression and its regulation in anural embryos

The muscle actin genes were used to investigate the mechanism of muscle cell regression of anural development (Kusakabe *et al.*, 1996). *MocuMA1* is a single-copy, larval muscle actin gene in the urodele ascidian *M. oculata*. The accumulation of muscle actin mRNA in *M. occulta* anural embryos was investigated by *in situ* hybridization using the coding region of *MocuMA1* as a probe. The results showed that *M. occulta* embryos do not produce detectable amounts of muscle actin mRNA during embryogenesis (Kusakabe *et al.*, 1996). The *MocuMA1* probe can detect muscle actin mRNA in embryos of the urodele ascidian species *Molgula occidentalis* and *Styela clava*, which are more distantly related to *M. oculata* than is *M. occulta*. Therefore, the inability of the *MocuMA1* probe to detect muscle actin transcripts in the *M. occulta* embryos seems due to lack of muscle actin gene expression but not to sequence divergence between the *M. occulta* and *M. oculata* muscle actin genes. The larval muscle actin gene(s) is probably silent or downregulated in *M. occulta* embryos. The sister species *M. occulta* and *M. oculata* are capable of interspecific hybridization (Swalla and

Jeffery, 1990). The results of *in situ* hybridization experiments with the *MocuMA1* coding region probe showed that muscle actin mRNA accumulates in the vestigial muscle cells of hybrid embryos produced by fertilizing *M. occulta* eggs with *M. oculata* sperm (Kusakabe *et al.*, 1996). Thus, muscle actin gene expression is restored in the vestigial muscle cells of hybrid embryos.

pMocuMA1-Z is a fusion gene construct consisting of the 702-bp 5' upstream region of the *MocuMA1* gene fused with the *lacZ* gene that is expressed in the tail muscle cells of urodele embryos. To investigate whether *trans*-acting factors required for *MocuMA1* expression are present in *M. occulta* embryos, pMocuMA1-Z was microinjected into *M. occulta* eggs and the resulting larvae were assayed for  $\beta$ -galactosidase activity (Fig. 7; Kusakabe *et al.*, 1996). Expression of pMocuMA1-Z was observed in a few vestigial muscle cells in the posterior region of *M. occulta* larvae, suggesting that *trans*-acting factors responsible for expression of the *MocuMA1* gene in the muscle cell lineage have been retained in *M. occulta* embryos (Fig. 4C).

**(iii) Loss-of-function mutations of muscle actin genes in anural ascidians**

If *trans*-acting factors regulating *MocuMA1* gene expression are retained in *M. occulta* embryos, then lack of muscle actin gene expression must be due to other evolutionary changes. Two muscle actin genes *MocccMA1a* and *MocccMA1b*,

which are orthologous to *MocuMA1*, were isolated from an *M. occulta* genomic library (Kusakabe *et al.*, 1996). The coding regions of the *MocccMA1a* and *MocccMA1b* genes contains deletions, insertions, and codon substitutions that would make their encoded polypeptide nonfunctional as actins. The frame-shifts in the *MocccMA1a* and *MocccMA1b* genes would generate stop codons, causing premature termination of translation. These features suggest that muscle actin gene expression has been altered in *M. occulta* by mutations in the *MocccMA1a* and *MocccMA1b* genes.

The *MocccMA1a* gene shows strong similarity to *MocuMA1* in its 5'- and 3'-flanking sequences, including the putative promoter region. The 5'- and 3'-flanking regions of the *MocccMA1b* gene are less conserved relative to the *MocuMA1* gene. Promoter activity in the 5' upstream regions of the *MocccMA1a* and *MocccMA1b* genes was investigated by microinjecting promoter-*lacZ* fusion gene constructs into eggs of the urodele ascidian *Ciona intestinalis* (Kusakabe *et al.*, 1996). Interestingly, expression of *MocccMA1a/lacZ* and *MocccMA1b/lacZ* fusion constructs showed that they both retain muscle-specific promoter activity, although it is reduced in *MocccMA1b*.

Our analysis on muscle actin genes suggest that the regression of muscle cell differentiation in *M. occulta* embryos is mediated by loss-of-function mutations in muscle actin genes, which have become pseudogenes, rather than by changes in *trans*-acting regulatory factors required for expression of these genes (Fig. 8; Kusakabe *et al.*, 1996). Other

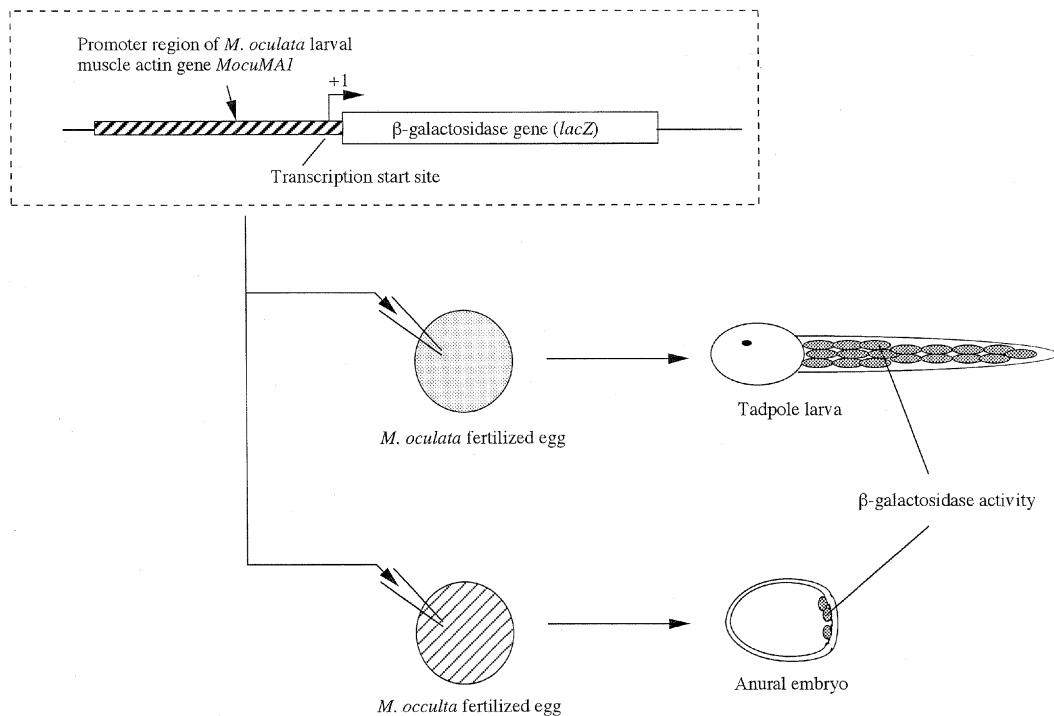

**Fig. 7.** A schematic diagram illustrating an experimental system to demonstrate the presence of muscle-specific *trans*-acting factors in the *M. occulta* anural embryos. Promoter-*lacZ* fusion gene constructs of muscle actin gene of the urodele species *M. oculata* are microinjected into fertilized eggs of *M. oculata* or *M. occulta*.  $\beta$ -Galactosidase activity is detected not only in the tail muscle cells of *M. oculata* tadpole larva but also in the vestigial muscle cells of *M. occulta* anural larva.

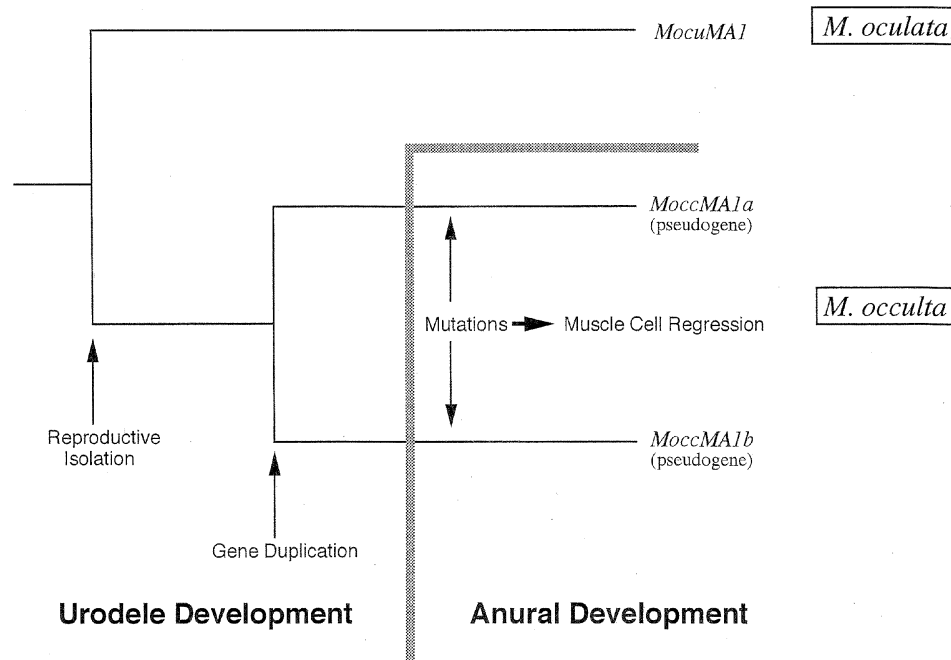

**Fig. 8.** A schematic diagram showing the proposed evolutionary relationship for the timing of the *MoccMA1* gene duplication event, the origin of anural development in *M. occulta*, and the accumulation of loss-of-function mutations in the *MoccMA1a* and *MoccMA1b* genes. The loss-of-function mutations in the *MoccMA1* genes probably mediated the muscle cell regression during the evolution of anural development.

changes leading to lack of muscle cell differentiation in anural embryos, such as the loss of myosin gene expression (Swalla and Jeffery, 1990), may be due to similar changes in gene structure. Loss of function of tissue-specific structural genes by *cis*-mutation may be an important mechanism of regression of certain cell types as an evolutionary modification of development.

## 6. CONCLUSIONS

Actin genes have provided a unique system to study developmental and evolutionary mechanisms in ascidians.

(1) Multiple muscle actin genes are expressed during larval muscle cell development. In the genome these genes form clusters which may have evolved to synthesize a large amount of actin during rapid differentiation of larval muscle cells. Further studies on the transcriptional regulation of the actin gene clusters may provide information on the role of genomic structure in the regulation of transcription.

(2) Expression patterns and *cis*-regulatory elements of the larval muscle actin genes have been analyzed in detail. Rather short upstream sequences of the 5' flanking region of muscle actin genes are responsible for the tissue-specific expression of the genes. Investigating *trans*-acting factors controlling expression of larval muscle actin genes may lead to identification of muscle determinants localized in egg cytoplasm.

(3) Ascidians have distinct actin isoforms for adult muscle. The adult muscle actin genes have been used to study heterochrony in ascidian development and may be useful tools

to investigate adult muscle development.

(4) Ascidians probably have multiple nonmuscle actin isoforms whose sequences and expression patterns are distinct. They can be used as molecular markers for certain cell types such as mesenchyme cells.

(5) Phylogenetic analysis of actin sequences suggests a close relationship between ascidian and vertebrate actins. The chordate ancestor seems to have evolved the "chordate-type" cytoplasmic and muscle actins before its divergence into vertebrates and urochordates. The phylogenetic analysis also suggests that vertebrate actin isoforms evolved after the separation of the vertebrates and urochordates.

(6) Muscle actin genes have been used to investigate the mechanism of muscle cell regression during the evolution of anural development. The results suggest that this process is mediated by changes in the structure of muscle actin genes rather than in the *trans*-acting regulatory factors required for their expression.

Future studies using ascidian actin genes may further elucidate fundamental problems in development and evolution. In addition to ascidian actin genes, future studies on actin genes in hemichordates and other chordates, including amphioxus, salps, larvaceans, lampreys, hagfish, and jawed fish would provide important information about chordate evolution as well as evolution of gene regulation and development.

## ACKNOWLEDGMENTS

I thank Drs. Noriyuki Satoh, William R. Jeffery, Kazuhiro W. Makabe, Akira Hikosaka, Isato Araki, Billie J. Swalla, and Yutaka Satou

for their collaboration and encouragement in this research. I am also grateful to Dr. William R. Jeffery for critical reading of the manuscript. Our research described here was supported in part by Grants-in-Aid from the Ministry of Education, Science, Sports and Culture of Japan to T.K. and Dr. Noriyuki Satoh, and by NIH and NSF grants to Dr. William R. Jeffery.

## REFERENCES

- Araki I, Saiga H, Makabe KW, Satoh N (1994) Expression of AMD1, a gene for a MyoD1-related factor in the ascidian *Halocynthia roretzi*. *Roux's Arch Dev Biol* 203: 320–327
- Araki I, Satoh N (1996) *cis*-Regulatory elements conserved in the proximal promoter region of an ascidian embryonic muscle myosin heavy-chain gene. *Dev Genes Evol* 206: 54–63
- Araki I, Tagawa K, Kusakabe T, Satoh N (1996) Predominant expression of a cytoskeletal actin gene in mesenchyme cells during embryogenesis of the ascidian *Halocynthia roretzi*. *Dev Growth Differ* 38: 401–411
- Bates WR, Mallett JE (1991) Ultrastructural and histochemical study of anural development in the ascidian *Molgula pacifica* (Huntsman). *Roux's Arch Dev Biol* 200: 193–201
- Beach RL, Jeffery WR (1990) Temporal and spatial expression of a cytoskeletal actin gene in the ascidian *Styela clava*. *Dev Genet* 11: 2–14
- Beach RL, Jeffery WR (1992) Multiple actin genes encoding the same  $\alpha$ -muscle isoform are expressed during ascidian development. *Dev Biol* 151: 55–66
- Berrill NJ (1931) Studies in tunicate development. Part II. Abbreviation of development in the Molgulidae. *Phil Trans R Soc Lond Biol* 219: 281–346
- Bhattacharya D, Stickel SK (1994) Sequence analysis of duplicated actin genes in *Lagenidium giganteum* and *Pythium irregulare* (Oomycota). *J Mol Evol* 39: 56–61
- Cox RD, Buckingham ME (1992) Actin and myosin genes are transcriptionally regulated during mouse skeletal muscle development. *Dev Biol* 149: 228–234
- Davidson EH (1986) *Gene Activity in Early Development*. 3rd ed, Academic Press, Inc, Orlando, FL
- Doolittle WF (1978) Genes in pieces: were they ever together? *Nature* 272: 581–582
- Ermak TH (1975) Cell proliferation in the digestive tract of *Styela clava* (Urochordata: Ascidiacea) as revealed by autoradiography with tritiated thymidine. *J Exp Zool* 194: 449–466
- Ermak TH (1976) Renewal of the gonads in *Styela clava* (Urochordata: Ascidiacea) as revealed by autoradiography with tritiated thymidine. *Tissue Cell* 8: 471–478
- Felsenstein J (1985) Confidence limits on phylogenies: an approach using the bootstrap. *Evolution* 39: 783–791
- Fyrberg EA, Bond BJ, Hershey ND, Mixter KS, Davidson N (1981) The actin genes of *Drosophila*: protein coding regions are highly conserved but intron positions are not. *Cell* 24: 107–116
- Gossett LA, Kelvin DJ, Sternberg EA, Olson EN (1989) A new myocyte-specific enhancer-binding factor that recognizes a conserved element associated with multiple muscle-specific genes. *Mol Cell Biol* 9: 5022–5033
- Grave C (1926) *Molgula citrina* (Alder and Hancock). Activities and structure of the free-swimming larva. *J Morphol* 42: 453–471
- Hadfield KA, Swalla BJ, Jeffery WR (1995) Multiple origins of anural development in ascidians inferred from rDNA sequences. *J Mol Evol* 40: 413–427
- Hasty P, Bradley A, Morris JH, Edmondson DG, Venuti JM, Olson EN, Klein WH (1993) Muscle deficiency and neonatal death in mice with a targeted mutation in the *myogenin* gene. *Nature* 364: 501–506
- He M, Haymer DS (1995) Codon bias in actin multigene families and effects on the reconstruction of phylogenetic relationships. *J Mol Evol* 41: 141–149
- Hikosaka A, Kusakabe T, Satoh N, Makabe KW (1992) Introduction and expression of recombinant genes in ascidian embryos. *Dev Growth Differ* 34: 627–634
- Hikosaka A, Satoh N, Makabe KW (1993) Regulated spatial expression of fusion gene constructs with the 5' upstream region of *Halocynthia roretzi* muscle actin gene in *Ciona savignyi* embryos. *Roux's Arch Dev Biol* 203: 104–112
- Hikosaka A, Kusakabe T, Satoh N (1994) Short upstream sequences associated with muscle-specific expression of an actin gene in ascidian embryos. *Dev Biol* 166: 763–769
- Iwabe N, Kuma K, Miyata T (1996) Evolution of gene families and relationship with organismal evolution: rapid divergence of tissue-specific genes in the early evolution of chordates. *Mol Biol Evol* 13: 483–493
- Jägersten G (1972) *Evolution of the Metazoan Life Cycle. A Comprehensive Theory*. Academic Press, New York
- Jeffery WR (1994) Actin as a tissue-specific marker in studies of ascidian development and evolution. *Adv Dev Biol* 3: 137–183
- Jeffery WR, Beach RL, Harrington FE, Swalla BJ, White ME (1990) Patterns of gene expression during ascidian development. In "Experimental Embryology in Aquatic Plants and Animals" Ed by Marthy HJ, Plenum Press, New York, pp 291–314
- Jeffery WR, Swalla BJ (1990) Anural development in ascidians: evolutionary modification and elimination of the tadpole larva. *Semin Dev Biol* 1: 253–261
- Jeffery WR, Swalla BJ (1991) An evolutionary change in the muscle lineage of an anural ascidian embryo is restored by interspecific hybridization with a urodele ascidian. *Dev Biol* 145: 328–337
- Jeffery WR, Swalla BJ (1992a) Evolution of alternate modes of development in ascidians. *BioEssays* 14: 219–226
- Jeffery WR, Swalla BJ (1992b) Factors necessary for restoring an evolutionary change in an anural ascidian embryo. *Dev Biol* 153: 194–205
- Kalk M (1970) The organization of a tunicate heart. *Tissue Cell* 2: 99–118
- Katz MJ (1983) Comparative anatomy of the tunicate tadpole, *Ciona intestinalis*. *Biol Bull* 164: 1–27
- Kovilur S, Jacobson JW, Beach RL, Jeffery WR, Tomlinson CR (1993) Evolution of the chordate muscle actin gene. *J Mol Evol* 36: 361–368
- Kusakabe T (1995) Expression of larval-type muscle actin-encoding genes in the ascidian *Halocynthia roretzi*. *Gene* 153: 215–218
- Kusakabe T, Suzuki J, Saiga H, Jeffery WR, Makabe KW, Satoh N (1991) Temporal and spatial expression of a muscle actin gene during embryogenesis of the ascidian *Halocynthia roretzi*. *Dev Growth Differ* 33: 227–234
- Kusakabe T, Makabe KW, Satoh N (1992) Tunicate muscle actin genes: structure and organization as a gene cluster. *J Mol Biol* 227: 955–960
- Kusakabe T, Hikosaka A, Satoh N (1995) Coexpression and promoter function in two muscle actin gene complexes of different structural organization in the ascidian *Halocynthia roretzi*. *Dev Biol* 169: 461–472
- Kusakabe T, Swalla BJ, Satoh N, Jeffery WR (1996) Mechanism of an evolutionary change in muscle cell differentiation in ascidians with different modes of development. *Dev Biol* 174: 379–392
- Kusakabe T, Araki I, Satoh N, Jeffery WR (1997) Evolution of chordate actin genes: evidence from genomic organization and amino acid sequences. *J Mol Evol* 44: 289–298
- Lassar AB, Davis RL, Wright WE, Kadesch T, Murre C, Voronova A, Baltimore D, Weintraub H (1991) Functional activity of myogenic HLH proteins requires hetero-oligomerization with E12/E47-like proteins *in vivo*. *Cell* 66: 305–315
- Makabe KW, Satoh N (1989) Temporal expression of myosin heavy chain gene during ascidian embryogenesis. *Dev Growth Differ*



- 31: 71–77
- Marikawa Y, Yoshida S, Satoh N (1994) Development of egg fragments of the ascidian *Ciona savignyi*: the cytoplasmic factors responsible for muscle differentiation are separated into a specific fragment. *Dev Biol* 162: 134–142
- Marikawa Y, Yoshida S, Satoh N (1995) Muscle determinants in the ascidian egg are inactivated by UV irradiation and the inactivation is partially rescued by injection of maternal mRNAs. *Roux's Arch Dev Biol* 204: 180–186
- Minty A, Kedes L (1986) Upstream regions of the human cardiac actin gene that modulate its transcription in muscle cells: presence of an evolutionarily conserved repeated motif. *Mol Cell Biol* 6: 2125–2136
- Miwa T, Manabe Y, Kurokawa K, Kamada S, Kanda N, Bruns G, Ueyama H, Kakunaga T (1991) Structure, chromosome location, and expression of the human smooth muscle (enteric type)  $\gamma$ -actin gene: evolution of six human actin genes. *Mol Cell Biol* 11: 3296–3306
- Miyata T, Kuma K, Iwabe N, Nikoh N (1994) A possible link between molecular evolution and tissue evolution demonstrated by tissue specific genes. *Jpn J Genet* 69: 473–480
- Nevitt G, Gilly WF (1986) Morphological and physiological properties of non-striated muscle from the tunicate, *Ciona intestinalis*: parallels with vertebrate skeletal muscle. *Tissue Cell* 18: 341–360
- Nishida H (1987) Cell lineage analysis in ascidian embryos by intracellular injection of a tracer enzyme. III. Up to the tissue restricted stage. *Dev Biol* 121: 526–541
- Nishikata T, Mita-Miyazawa I, Deno T, Satoh N (1987) Monoclonal antibodies against components of the myoplasm of eggs of the ascidian *Ciona intestinalis* partially block the development of muscle-specific acetylcholinesterase. *Development* 100: 577–586
- Pollard TD, Cooper JA (1986) Actin and actin-binding proteins. A critical evaluation of mechanisms and functions. *Annu Rev Biochem* 55: 987–1035
- Raff EC, Diaz HB, Hoyle HD, Hutchens JA, Kimble M, Raff RA, Rudolph JE, Subler MA (1987) Origin of multiple gene families: are there both functional and regulatory constraints? In "Development as an Evolutionary Process" Ed by RA Raff and EC Raff, Alan R Liss, Inc, New York, pp 203–238
- Rawls A, Morris JH, Rudnicki M, Braun T, Arnold H-H, Klein WH, Olson EN (1995) Myogenin's functions do not overlap with those of MyoD or Myf-5 during mouse embryogenesis. *Dev Biol* 172: 37–50
- Saitou N, Nei M (1987) The neighbor-joining method: a new method for reconstructing phylogenetic trees. *Mol Biol Evol* 4: 406–425
- Satoh N (1994) *Developmental Biology of Ascidiaceans*. Cambridge Univ Press, New York
- Satoh N, Jeffery WR (1995) Chasing tails in ascidians: developmental insights into the origin and evolution of chordates. *Trends Genet* 11: 354–359
- Satoh N, Araki I, Satou Y (1996) An intrinsic program for autonomous differentiation of muscle cells in the ascidian embryo. *Proc Natl Acad Sci USA* 93: 9315–9321
- Satou Y, Kusakabe T, Araki I, Satoh N (1995) Timing of initiation of muscle-specific gene expression in the ascidian embryo precedes that of developmental fate restriction in lineage cells. *Dev Growth Differ* 37: 319–327
- Satou Y, Satoh N (1996) Two *cis*-regulatory elements are essential for the muscle-specific expression of an actin gene in the ascidian embryo. *Dev Growth Differ* 38: 565–573
- Sheterline P, Sparrow JC (1994) Actin. *Protein Profile* 1: 1–121
- Shinohara Y, Konishi K (1982) Ultrastructure of the body-wall muscle of the ascidian *Halocynthia roretzi*: smooth muscle cell with multiple nuclei. *J Exp Zool* 221: 137–142
- Swalla BJ (1993) Mechanisms of gastrulation and tail formation in ascidians. *Microsc Res Tech* 26: 274–284
- Swalla BJ, Jeffery WR (1990) Interspecific hybridization between an anural and urodele ascidian: differential expression of urodele features suggests multiple mechanisms control anural development. *Dev Biol* 142: 319–334
- Swalla BJ, Jeffery WR (1992) Vestigial brain melanocyte development during embryogenesis of an anural ascidian. *Dev Growth Differ* 34: 17–25
- Swalla BJ, Jeffery WR (1996) Requirement of the *Manx* gene for expression of chordate features in a tailless ascidian larva. *Science* 274: 1205–1208
- Swalla BJ, Makabe KW, Satoh N, Jeffery WR (1993) Novel genes expressed differentially in ascidians with alternate modes of development. *Development* 119: 307–318
- Swalla BJ, White ME, Zhou J, Jeffery WR (1994) Heterochronic expression of an adult muscle actin gene during ascidian larval development. *Dev Genet* 15: 51–63
- Terakado K, Obinata T (1987) Structure of multinucleated smooth muscle cells of the ascidian *Halocynthia roretzi*. *Cell Tissue Res* 247: 85–94
- Tomlinson CR, Beach RL, Jeffery WR (1987) Differential expression of a muscle actin gene in muscle cell lineages of ascidian embryos. *Development* 101: 751–765
- Vandekerckhove J, Weber K (1978) Mammalian cytoplasmic actins are the products of at least two genes and differ in primary structure in at least 25 identified positions from skeletal muscle actins. *Proc Natl Acad Sci USA* 75: 1106–1110
- Vandekerckhove J, Weber K (1979) The complete amino acid sequence of actins from bovine aorta, bovine heart, bovine fast skeletal muscle, and rabbit slow skeletal muscle. *Differentiation* 14: 123–133
- Vandekerckhove J, Weber K (1984) Chordate muscle actins differ distinctly from invertebrate muscle actins. The evolution of the different vertebrate muscle actins. *J Mol Biol* 179: 391–413
- Whittaker JR (1979) Development of vestigial tail muscle acetylcholinesterase in embryos of an anural ascidian species. *Biol Bull* 156: 393–407

(Received April 30, 1997 / Accepted June 12, 1997)