

The Ubiquitination Machinery of the Ubiquitin System

Author: Callis, Judy

Source: The Arabidopsis Book, 2014(12)

Published By: The American Society of Plant Biologists

URL: <https://doi.org/10.1199/tab.0174>

BioOne Complete (complete.BioOne.org) is a full-text database of 200 subscribed and open-access titles in the biological, ecological, and environmental sciences published by nonprofit societies, associations, museums, institutions, and presses.

Your use of this PDF, the BioOne Complete website, and all posted and associated content indicates your acceptance of BioOne's Terms of Use, available at www.bioone.org/terms-of-use.

Usage of BioOne Complete content is strictly limited to personal, educational, and non - commercial use. Commercial inquiries or rights and permissions requests should be directed to the individual publisher as copyright holder.

BioOne sees sustainable scholarly publishing as an inherently collaborative enterprise connecting authors, nonprofit publishers, academic institutions, research libraries, and research funders in the common goal of maximizing access to critical research.

First published on October 10, 2014: e0174. doi: 10.1199/tab.0174

The Ubiquitination Machinery of the Ubiquitin System

Judy Callis

Department of Molecular and Cellular Biology, University of California-Davis, Davis CA 95616

Address correspondence to jcallis@ucdavis.edu

The protein ubiquitin is a covalent modifier of proteins, including itself. The ubiquitin system encompasses the enzymes required for catalysing attachment of ubiquitin to substrates as well as proteins that bind to ubiquitinated proteins leading them to their final fate. Also included are activities that remove ubiquitin independent of, or in concert with, proteolysis of the substrate, either by the proteasome or proteases in the vacuole. In addition to ubiquitin encoded by a family of fusion proteins, there are proteins with ubiquitin-like domains, likely forming ubiquitin's β -grasp fold, but incapable of covalent modification. However, they serve as protein-protein interaction platforms within the ubiquitin system. Multi-gene families encode all of these types of activities. Within the ubiquitination machinery "half" of the ubiquitin system are redundant, partially redundant, and unique components affecting diverse developmental and environmental responses in plants. Notably, multiple aspects of biotic and abiotic stress responses require, or are modulated by, ubiquitination. Finally, aspects of the ubiquitin system have broad utility: as components to enhance gene expression or to regulate protein abundance. This review focuses on the ubiquitination machinery: ubiquitin, unique aspects about the synthesis of ubiquitin and organization of its gene family, ubiquitin activating enzymes (E1), ubiquitin conjugating enzymes (E2) and ubiquitin ligases, or E3s. Given the large number of E3s in Arabidopsis this review covers the U box, HECT and RING type E3s, with the exception of the cullin-based E3s.

INTRODUCTION

Historical Perspective

The first studies leading to the 2004 Nobel Prize in Chemistry awarded for work on the ubiquitin system to researchers Avram Hershko, Aaron Ciechanover and Irwin Rose were published in 1978-1980 [for summary of this early work, see (Wilkinson, 2005)]. They were investigating *in vitro* proteolysis using lysates of rabbit immature red blood cells (called reticulocytes). Significantly, reticulocytes lack lysosomes, the mammalian equivalent of the plant vacuole, thus absent are proteases typically located in this compartment released upon cell lysis that could confound interpretation. During these studies, several curious phenomena were observed. The first was that degradation of model substrates was ATP-dependent; second, it required the presence of a small proteinaceous substance with unusual (for a protein) heat stable properties (Ciechanover et al., 1978) and third, substrates became *larger* prior to degradation as assessed by gel electrophoresis (Ciechanover et al., 1980). Prior to elucidating its identity, the heat stable proteinaceous substance was initially named APF-1, for ATP-dependent proteolysis factor 1 (Hershko et al., 1980). Subsequent analyses (Wilkinson et al., 1980) revealed that APF-1 had already been identified twice previously; as ubiquitin, a "universally

present" protein that promoted lymphocyte differentiation *in vitro* (Goldstein et al., 1975), and as an integral component of the mammalian chromosomal protein A-24, a covalent adduct connecting ubiquitin and histone-H2A (Goldknopf and Busch, 1977).

The early curious observations have been explained; ubiquitin's heat stable nature stems from extensive intra-molecular interactions (Vijay-Kumar et al., 1987a) and the observed higher molecular weight forms of substrates result from covalent conjugation of a minimum of four ubiquitins in a chain to the substrate protein prior to degradation (Ciechanover et al., 1980; Hershko et al., 1980; Thrower et al., 2000). This process of ubiquitin conjugation, also called ligation, requires ATP hydrolysis to provide the energy for what is essentially peptide bond formation between ubiquitin and the substrate protein (Ciechanover et al., 1980). Since first discovered as a proteolytic pathway, ubiquitin modification is often called the UPS, for ubiquitin-proteasome system. However, this title does not accurately describe ubiquitin's non-proteolytic roles, and hence the term Ubiquitin System is a preferred name that encompasses both proteasomal and non-proteasomal fates for ubiquitinated proteins (Hershko and Ciechanover, 1998). Ubiquitinated proteins with diverse fates are produced by the same kinds of activities of the ubiquitination machinery, so it is logical to include them all under the rubric of the Ubiquitin System.

Overview of the Ubiquitin System

The ubiquitin system is an intracellular protein modification pathway for cytosolic, membrane-localized and nuclear proteins. Initially unexpected is the breadth of intracellular processes subsequently revealed to be regulated by the ubiquitin system. Recent proteomic studies have revealed a large number of ubiquitinated proteins, and the ubiquitination events of most have yet to be described. Ubiquitination is diverse: addition of one or more ubiquitins in different configurations gives the system flexibility and diversity for varied outcomes, so both proteolytic and non-proteolytic fates for ubiquitin modified proteins have been documented. Gene expression is under the influence of ubiquitin via histone modification and modulation of transcription factor activity/abundance. The activity, longevity and/or localization of intracellular signaling pathway components are ubiquitin-modulated. Finally, metabolic pathways haven't escaped the ubiquitin umbrella; enzymes for key steps can be modified by ubiquitin, altering either their longevity or activity. Required for all of the above ubiquitin modifications are the shaft and ribs of the ubiquitin umbrella that support the cellular canvas: ubiquitin and the E1, E2 and E3 ubiquitination activities.

The process of ubiquitination (or equivalently, ubiquitylation) typically requires three distinct biochemical activities (Figure 1). The first enzyme, E1, catalyzes ubiquitin "activation", a term referring to adenylation of the ubiquitin C-terminal carboxyl group (Figure 2), and after ubiquitin transfer to a cysteinyl residue on E1, also refers to thioester-linked ubiquitin. Activated ubiquitin is transferred from E1 to a cysteinyl residue in a second protein called E2. Transfer of ubiquitin to substrate proteins typically requires a third activity called E3 or ligase. Depending on the E3, substrate ubiquitination occurs by direct transfer to the substrate from the E2 or after thioester formation of ubiquitin with the E3. Typically, ubiquitin forms a peptide bond with the ϵ -NH₂ group on substrate lysyl residues termed an isopeptide bond, but more recently, ubiquitin ligation to the N-terminal α -NH₂ group, or to serine, threonine or cysteine substrate residues forming peptide, ester or thioester linkages, respectively, with substrate proteins has been described in mammalian cells.

Subsequent ubiquitination can occur repetitively on the same substrate, either at additional sites (multi-monoubiquitination), or in polyubiquitination, the first added ubiquitin serves as the "acceptor" of additional ubiquitins (at the acceptor ubiquitin's one or more ϵ -NH₂ lysyl groups or much less frequently, at the α -NH₂ group) (Behrends and Harper, 2011). The complexity of ubiquitination products varying in the position, extent and/or nature of ubiquitin-ubiquitin linkages on a substrate protein (Figure 3) contributes to the diversity of downstream consequences (Bremm et al., 2010; Behrends and Harper, 2011; Komander and Rape, 2012; Kulathu and Komander, 2012; Walsh and Sadanandom, 2014). The ubiquitinated protein can be recognized by one of many ubiquitin-binding proteins or ubiquitin receptors that ferry ubiquitinated proteins to specific sites (Dikic et al., 2009). Several proteins in the regulatory subunit of the large catalytic protease, the proteasome, tether ubiquitinated proteins to the proteasome complex (Van Nocker et al., 1996a; Fu et al., 1998; Fu et al., 2010). After and/or during de-ubiquitination and unfolding, pro-

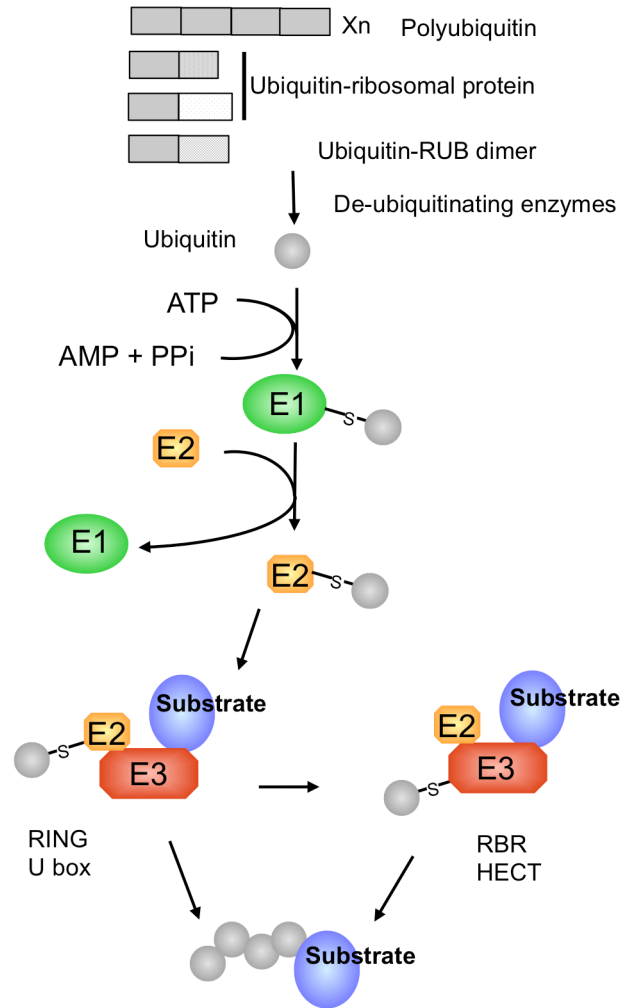

Figure 1. Ubiquitin genes and ubiquitination pathway.

Ubiquitin is encoded by a family of protein fusions that must be processed by de-ubiquitinating enzymes to release active ubiquitin. Ubiquitin is activated by E1, and thioester conjugated first to E1, then to E2. E2-Ub interacts with an E3. In the case of RING and U box E3s, an intermediate complex of substrate, E3 and E2-Ub is required for transfer to substrate. For RBR and HECT-type E3s, E2-Ub interacts and transfers ubiquitin to an E3 cysteinyl sulfhydryl prior to ubiquitin transfer to substrate.

teins ratchet into the proteasome core for peptide bond hydrolysis at three distinct active sites. Peptides are released by an unknown mechanism and ubiquitin is released by de-ubiquitinating enzymes (DUBs) intact for another cycle of attachment (Wing, 2003; Lee et al., 2011; Eletr and Wilkinson, 2014; Isono and Nagel, 2014). Other ubiquitinated proteins, such as plasma membrane proteins, are targeted to the vacuole for degradation and de-ubiquitination is key to proper intracellular trafficking (Acconcia et al., 2009; MacGurn et al., 2012; Tanno and Komada, 2013; Tian and Xie, 2013). Alternatively, ubiquitinated proteins are recognized and trigger signal transduction cascades, either in the

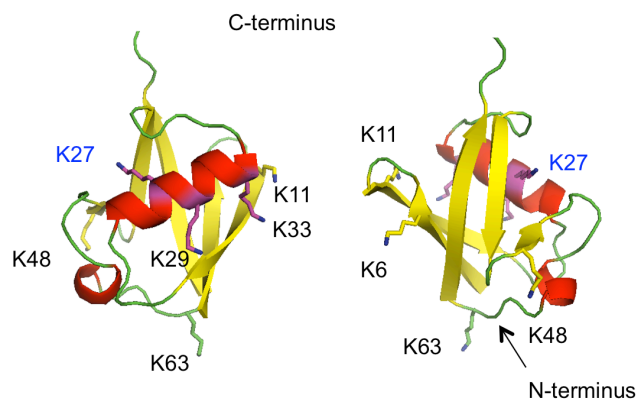

Figure 2. Ribbon diagram representations of human ubiquitin (1.UBQ.pdb).

The side chains of the seven lysine residues (6, 11, 27, 29, 33, 48 and 63) are shown in stick form, but not all are visible in each view (180° difference). K27 is in blue type because it was not identified as a ubiquitin-ubiquitin linkage site in Arabidopsis. The C-terminus is at top, the N-terminus at the bottom only visible in the right view. In red, helical regions; in yellow, β -strands.

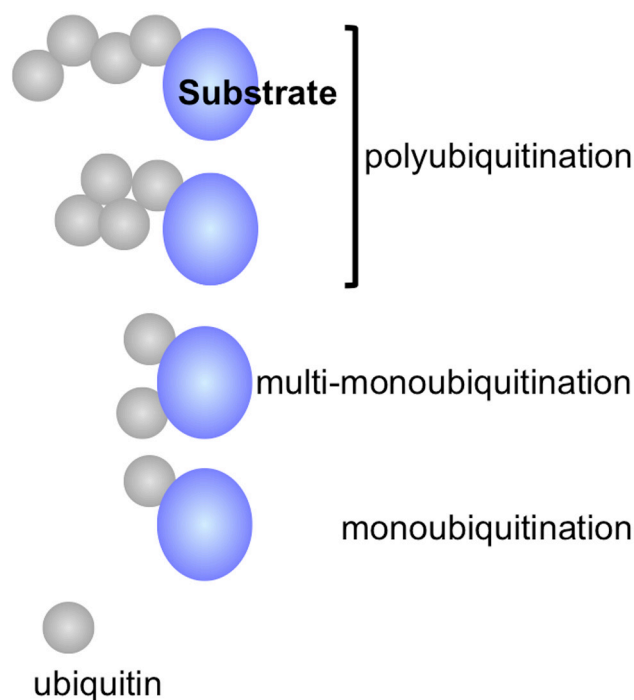

Figure 3. Representation of the diversity of ubiquitinated products.

In Arabidopsis, 6/7 lysine residues of ubiquitin serve as ubiquitin attachment sites, forming distinct polyubiquitin chains. K48, K11 and K63 chains are structurally distinct (different chain topology is represented by the top two polyubiquitinated substrates). In addition, substrates can be monoubiquitinated (bottom) or monoubiquitinated at multiple substrate sites (multi-monoubiquitination, second from bottom).

nucleus, cytosol or at the plasma membrane and are catabolized by de-ubiquitination. It is likely that the spectrum of processes regulated by ubiquitination is not fully described.

When the large list of ubiquitinating enzymes is added to the lists of ubiquitin proteases that reverse conjugation, proteasome subunits, proteins with ubiquitin-like domains and ubiquitin binding proteins, a significant fraction of the eukaryotic genome encodes ubiquitin system components. This article will focus on the modification process: ubiquitin, ubiquitin-like proteins (UBLs) and proteins with ubiquitin-like domains (UbLDs) and the ubiquitination machinery; E1, E2 and E3 activities required for modification. Recent advances in our understanding of E2-E3 interactions and the biological roles of select E3s will be highlighted. Not included is the class of E3s with a cullin-type protein as scaffold. This large subgroup is expertly reviewed elsewhere (Smalle and Vierstra, 2004; Thomann et al., 2005; Lechner et al., 2006; Santner and Estelle, 2010; Hua and Vierstra, 2011; Vierstra, 2011; Wang and Deng, 2011; Choi et al., 2014). Other interesting aspects of the ubiquitin system are not included such as the superfamily of ubiquitin binding proteins that exploit surfaces, and/or conformations of ubiquitin and UbLD-containing proteins to achieve specific outputs (Kirkin and Dikic, 2007; Dikic et al., 2009) and the proteasome composition and regulation (Book et al., 2009; Book et al., 2010; Russell et al., 2013). The de-ubiquitinating enzymes that play roles in modulating the abundance and nature of ubiquitinated proteins, though also worthy of attention (Isono and Nagel, 2014) are not included in this review. For those interested in the evolution of the ubiquitin system and its prokaryotic relatives, please see specific reviews on this subject (Iyer et al., 2006; Hochstrasser, 2009; Vierstra, 2012).

UBIQUITIN PROTEIN AND GENES

Ubiquitin protein

Ubiquitin is a 76-amino acid polypeptide (Figure 2). Within vertebrates and higher plants, the amino acid sequence is absolutely conserved and the differences between animal, plant, and fungal ubiquitins are two or three residues (Callis and Vierstra, 1989). This remarkable degree of conservation suggests that ubiquitin from different species may be functionally interchangeable, and examining ubiquitin's efficiency as an E1 substrate *in vitro* did not yield evidence to the contrary (Haas and Rose, 1982). Replacement of yeast ubiquitin by Arabidopsis ubiquitin as the sole source of the protein in *Saccharomyces cerevisiae* did not result in any obvious phenotypic differences from strains expressing yeast ubiquitin (Ling et al., 2000).

Logically, ubiquitin structure is also conserved (Vijay-Kumar et al., 1987a), and is virtually identical whether derived from human, budding yeast, or plant (oat) ubiquitin (Vijay-Kumar et al., 1987b). Ubiquitin is a β -grasp fold protein, consisting of 3.5 turns of an amphipathic α -helix and a short 3_{10} -helix packed against a five-strand β -sheet with seven reverse turns [Figure 2, (Vijay-Kumar et al., 1987a)]. In addition to a core of sixteen-seventeen hydrophobic residues, there is extensive intramolecular hydrogen bonding. Altogether the properties of tight packing, a large hydrophobic core and extensive hydrogen bonding apparently confer structural stability, explaining its heat stable properties. When

fractionated by normal SDS-PAGE systems, this 8.5 kDa protein migrates with an apparent molecular weight of 5.5 kDa (Ciechanover et al., 1980), unusual for a hydrophilic protein and probably indicative of ubiquitin's refusal to completely denature into random coils even under the extreme conditions of SDS-PAGE sample preparation. Whereas the N-terminus immediately leads into a β -strand and the sulphur of Met-1 is hydrogen bonded to the backbone nitrogen of residue 63 and is therefore quite rigid, the carboxy-terminal two residues are not visualized in crystal structures, indicating flexibility. This likely reflects the requirement for minimization of steric hindrance upon covalent attachment of the C-terminus to other proteins.

The surface of ubiquitin is complex, with multiple functionalities, which explains its high degree of amino acid sequence conservation. The first loop containing Leu-8 is able to adopt different conformations important for interaction with distinct ubiquitin binding proteins (Lange et al., 2008). Another region, consisting of Ile-44, Leu-8, Val-70 and His-68, called the Ile-44 hydrophobic patch, interacts with the proteasome and other ubiquitin binding proteins. Alanine scanning mutational studies in yeast, using plasmid shuffling so that all the endogenously expressed ubiquitin can be replaced by a gene encoding a ubiquitin variant, tested the effect of single amino acid substitutions of surface residues on viability (Sloper-Mould et al., 2001). Surprisingly, in addition to the Ile-44 patch mentioned above and C-terminal residues important for attachment, only one other surface region proved to be essential. Residues around Phe-4, including Thr-12 and Gln-2 are the second essential surface (Sloper-Mould et al., 2001). There are likely additional non-essential interactions at other distinct sites on the ubiquitin surface that remain to be discovered. These studies indicate that multiple surfaces and/or conformations of ubiquitin provide diversity of interactions, likely contributing to the diverse outcomes.

Ubiquitin chains

One ubiquitin C-terminus can be covalently linked to a second ubiquitin via one of the latter's seven lysyl ϵ -amino groups or N-terminal amino group (Figure 2), forming ubiquitin chains. Thus, in addition to a single ubiquitin modification (monoubiquitination) or modification by one ubiquitin at multiple sites of the same substrate (multi-monoubiquitination), substrates can be modified by ubiquitin chains (polyubiquitination). In addition, the different ubiquitin-ubiquitin linkages form distinct conformations (Figure 3) and consequently utilize a distinct set of downstream interacting proteins that "interpret" the diverse ubiquitin signals.

Mass spectrometry has been used to determine the type of ubiquitin-ubiquitin linkages present *in vivo* as well as identify ubiquitination sites on substrate proteins. After isolation of ubiquitinated proteins including ubiquitinated ubiquitin, i.e., ubiquitin chains, trypsin cleavage leaves the C-terminal ubiquitin Gly-Gly dipeptide attached to tryptic peptides. If conjugated to a lysyl ϵ -NH₂ group, trypsin cleavage at this modified lysine acceptor side is inhibited, leaving a Gly-Gly dipeptide attached to an internal lysine in a peptide. These modified peptides are identified by mass shifting predicted tryptic peptides [loss of a cleavage at lysine and addition of Gly-Gly mass]. Thus in this manner, ubiquitin-ubiquitin linkages

are determined. Using quantitative methods, ubiquitin chains of highest abundance *in vivo* in Arabidopsis are Lys-48 linked (K48), then Lys-63 (K63) and Lys-11 (K11) linked chains. Following at much lower abundance are K33-, K6- and K29-linked ubiquitins (Maor et al., 2007; Kim et al., 2013). The only ubiquitin-ubiquitin linkage missing is via Lys-27, which interestingly is the only non-surface exposed lysine (Kim et al., 2013). Lys-27 ubiquitin linkages have been identified in yeast and mammalian cells (Meierhofer et al., 2008; Xu et al., 2009) and would require some conformational changes to expose this residue. Linear ubiquitin chains (linked through the α -NH₂ group) were not uncovered in Arabidopsis ubiquitin proteomic studies.

Two other goals of proteomic analyses are identification of ubiquitinated proteins and within these proteins, sites of ubiquitination. These studies have yielded a rich list of potential proteins implicated as substrates of the ubiquitin system (Maor et al., 2007; Manzano et al., 2008; Saracco et al., 2009; Kim et al., 2013). In contrast, results from evaluation of ubiquitination sites have been less informative. Despite revealing 216 distinct ubiquitination sites, no predictive conserved consensus sequence surrounding the lysyl residues utilized as points of ubiquitin attachment emerged (Kim et al., 2013).

Ubiquitin genes

The production of ubiquitin in Arabidopsis (and in all other eukaryotes) is rather unique and worth mention, mostly because of its utility in a variety of contexts. Ubiquitin in Arabidopsis, as well as all other organisms, is encoded in multiple genes as two different types of translational fusions: homomeric fusions and heteromeric fusions. Homomeric fusions are multimers of ubiquitin coding regions repeated head-to-tail with no intervening amino acids (called polyubiquitin) with the last ubiquitin terminating with one to a few additional amino acids. For heteromeric fusions, the 76-aa ubiquitin is followed in-frame by a different protein: one of two small ribosomal proteins (called ubiquitin-extension proteins), or by a ubiquitin-like protein called RUB (Related to Ub) [Table 1 and Figure 1 (Burke et al., 1988; Callis et al., 1989; Callis and Vierstra, 1989; Callis et al., 1990; Callis et al., 1995)]. Ubiquitin with even one additional C-terminal amino acid is unable to function in the conjugation pathway. This attribute means that ubiquitin initial translation products are non-functional until cleaved to release the active 76-amino acid protein; even the last ubiquitin requires removal of the few additional amino acids after Gly⁷⁶ before it is functional for conjugation. Perhaps this prevents ubiquitin conjugation while transiently associated with ribosomes. Alternatively, it could separate/distinguish ubiquitination of translation intermediates from synthesis of the protein ubiquitin.

The co-synthesis of ubiquitin and two different ribosomal proteins, found in yeast, animals and plants, is intriguing (Table 1). In budding yeast, processing of the 20S pre-rRNA is affected when the ribosomal protein encoded by the *UBI3* locus is expressed at wild type levels without ubiquitin. The processing defect can be reduced upon over-expression of the ribosomal protein. These results led to the hypothesis that co-expression with ubiquitin serves a chaperone function, facilitating pre-rRNA processing and ribosome assembly (Finley et al., 1989).

Several types of ubiquitin-specific proteases (de-ubiquitinases, DUBs) are capable of processing initial ubiquitin-fusion translation products. These hydrolytic enzymes cleave specifically after ubiquitin amino acid 76. Their specificity is quite remarkable: they require only the C-terminal Gly⁷⁵-Gly⁷⁶ residues of ubiquitin (the P2 and P1 sites, respectively), but care not a whit what lies immediately C-terminal to the cleavage site in the P' position [with the exception of proline, which is slowly cleaved (Gonda et al., 1989)]. This discovery led to the use of ubiquitin fusions to synthesize proteins with an N-terminal amino acid of choice (with the exception of proline) as follows. An open reading frame is constructed with one complete ubiquitin coding region at the N terminus, *immediately* followed in-frame by another open reading frame starting with the codon for one of 18 protein amino acids C-terminal to the 76th ubiquitin Gly codon (the exception being proline, and since proteins typically start with Met, a fusion protein expressing Met at the amino terminus serves as control). In eukaryotes, the ubiquitin-fusion protein is precisely cleaved after ubiquitin Gly⁷⁶, releasing the downstream protein with a "designer" N-terminus (Bachmair et al., 1986). If expressed in *E. coli*, which lacks the ubiquitin system and its processing proteases, addition of a recombinant ubiquitin-specific protease can achieve the release of the protein of interest, either by *in vivo* co-expression, or *in vitro* after lysis and/or purification of the fusion (Varshavsky, 2005). Thus, a protein with almost any N-terminus can be synthesized using this method in either prokaryotes or eukaryotes.

Use of ubiquitin fusions led to the discovery of the ubiquitin N-end rule pathway, that is, certain N-terminal amino acids serve as

a degradation signal, targeting the protein for ubiquitination by a specific E3, a test not possible without ubiquitin fusion synthesis and ubiquitin-specific proteases. Note that synthesis as a ubiquitin fusion is not biologically relevant to studies of the N-end rule; co-translational ubiquitin fusions are a trick to produce proteins with different N-termini. Separately, it was noted that co-synthesis with ubiquitin in *E. coli* enhanced a protein's solubility, suggesting this method of synthesis as a tool to enhance protein yield in *E. coli* in general (Varshavsky, 2005). In addition, ubiquitin fusions have been proposed to enhance protein expression in *Arabidopsis* (Hondred et al., 1999) and as a method to produce multiple proteins from the same mRNA (Walker and Vierstra, 2007).

The current ubiquitin gene count in *Arabidopsis thaliana* ecotype Columbia encoding and expressing at least one canonical ubiquitin is twelve (Table 1), comprised of five ubiquitin-ribosomal protein, five polyubiquitin and two ubiquitin-RUB (RELATED TO UBIQUITIN) encoding genes (Callis and Vierstra, 1989; Callis et al., 1990; Sun and Callis, 1993; Callis et al., 1995). This count may be slightly different in other ecotypes (see below). *UBQ1* (At3g52590) and *UBQ2* (At2g36170) encode the same polypeptide fusion of ubiquitin followed by a 52-amino acid large subunit ribosomal protein, L40. Similarly, in *UBQ5* (At3g62250), *UBQ6* (At2g47110) and *UBQ17* (At1g23410, previously unnamed) the N-terminal ubiquitin coding regions are followed by closely related but not identical 81-amino acid small subunit ribosomal proteins (S27a-3, -2, -1, respectively). A T-DNA insertion in *UBQ1* was uncovered in a screen for lines with pollen tube defects (*hap4*) (Johnson et al., 2004), with *hap4* pollen tubes growing randomly through

Table 1. Ubiquitin Genes and Pseudogenes

AGI Number	Gene*	Additional Gene Names	Nature of Initial Gene Product (RP= ribosomal protein)
At3g52590	<i>UBQ1</i>	<i>HAP4/ERD16/ EMB2167</i>	fusion of ubiquitin and 52 aa RP L40
At2g36170	<i>UBQ2</i>		fusion of ubiquitin and 52 aa RP L40
At5g03240.3	<i>UBQ3</i>		polyubiquitin
At5g20620	<i>UBQ4</i>		polyubiquitin
At3g62250	<i>UBQ5</i>		fusion of ubiquitin and RP S27a-3
At2g47110	<i>UBQ6</i>		fusion of ubiquitin and RP S27a-2
At2g35635	<i>UBQ7</i>	<i>RUB2</i>	ubiquitin-RUB1 fusion
At3g09790	<i>UBQ8</i>		no WT ubiquitin- pseudogene?
At5g37640	<i>UBQ9</i>		no WT ubiquitin- pseudogene?
At4g05320	<i>UBQ10</i>		polyubiquitin
At4g05050	<i>UBQ11</i>		polyubiquitin
At1g55060	<i>UBQ12</i>		no WT ubiquitin- mitochondrial DNA insertion in Columbia ecotype, not present in some ecotypes.
At1g65350	<i>UBQ13</i>		no WT ubiquitin- pseudogene?
At4g02890	<i>UBQ14</i>		polyubiquitin
At1g31340	<i>UBQ15</i>	<i>RUB1</i>	ubiquitin-RUB2 fusion
At1g11980	<i>UBQ16</i>	<i>RUB3</i>	RUB3 only, no ub fusion
At1g23410	<i>UBQ17</i>		fusion of ubiquitin and RP S27a-1

* in red are genes that encode at least one canonical ubiquitin coding region

wild type style, however, complementation with wild type sequence was not performed. *UBQ1* was isolated as an mRNA induced in leaves after 1 hour of drought treatment (also called ERD16, for Early Response to Drought), although northern analysis using ubiquitin as a probe suggests this induction is not unique to *UBQ1* (Kiyosue et al., 1994). *UBQ1* was also uncovered in a large screen for embryo defective mutants and corresponds to EMB_2167 (Murralla et al., 2011) (although, again no data from complementation test reported), suggesting that the paralog, *UBQ2*, encoding the identical protein does not provide sufficient protein at the required time. *UBQ1* and *UBQ2* are co-expressed genes (Pearson's correlation coefficient, $r=0.76$, www.bar.utoronto.ca) and both are widely expressed (Zimmermann et al., 2004), so delineation of the relative roles for *UBQ1* and *UBQ2* awaits further analysis.

Curiously, ubiquitin is co-synthesized with the ubiquitin-like (UBL) protein RUB (RELATED TO UBIQUITIN). Two genes, *RUB1/UBQ1* (At2g35635) and *RUB2/UBQ7* (At1g31340) (Rao-Naik et al., 1998), produce ubiquitin-RUB fusion proteins that have to be processed to produce active ubiquitin and active RUB. These two genes collectively are essential, likely because they are the major sources of RUB protein (Bostick et al., 2004).

The five ubiquitin polyubiquitin genes *UBQ3* (At5g03240), *UBQ4* (At5g20620), *UBQ10* (At4g05320), *UBQ11* (At4g05050), and *UBQ14* (At4g02890) in the Columbia ecotype encode polyproteins of 4, 5, 6, 3, and 4 ubiquitin coding regions, respectively (Burke et al., 1988; Callis et al., 1995). Interestingly, while ubiquitin genes within plants express the same protein, they are likely under positive selection since their coding regions contain the maximum number of synonymous substitutions without encoding any amino acid changes. The number of ubiquitin repeats within a gene does not appear to be constant, suggesting rapid evolution of repeat number (Sun et al., 1997). Among ten different ecotypes tested, *UBQ3* and *UBQ11* ubiquitin repeat number varies, ranging from 4-6 and 3-6 ubiquitin coding regions, respectively (Sun et al., 1997). In Columbia, all five polyubiquitin genes are widely expressed, and modulated individually by developmental and environmental factors (Sun and Callis, 1997). Of the polyubiquitin genes, *UBQ10* appears to be the most constitutively expressed (Sun and Callis, 1997) and emerged early as a recommended constitutive control for qPCR studies, borne out by Genevestigator profiles that show *UBQ10* expression to within four-fold for 98% of the samples (genevestigator.com, (Zimmermann et al., 2004), Dec 2013). However, its high level of expression limits its utility; subsequent studies have identified other superior reference mRNAs (Czechowski et al., 2005; Hong et al., 2010). The *UBQ10* promoter has been incorporated into plant expression vectors for constitutive expression (Grefen et al., 2010; Chen et al., 2011) and is considered roughly equivalent in expression to the 35S promoter in Arabidopsis (Norris et al., 1993).

All five Arabidopsis polyubiquitin genes contain a single intron located in the 5' untranslated region, and in *UBQ10*- and *UBQ3*-promoter chimeric constructs, the presence of the endogenous intron increased gene expression (Norris et al., 1993). Subsequent studies extended the utility of the *UBQ10* intron demonstrating that it enhances expression in all nine Arabidopsis reporter constructs tested with varying degrees of stimulation (Rose, 2002; Enami et al., 2013). These results suggest that the *UBQ10* intron is a general tool to enhance gene expression in Arabidopsis.

There are four additional polyubiquitin-like genes in Arabidopsis encoding ubiquitin-coding regions with amino acid substitutions [Table 1, (Callis et al., 1995)]. In addition to codon substitutions, *UBQ13* in the Columbia ecotype contains an insertion of mitochondrial DNA within the coding region, however, Ler, No-0 and RLD ecotypes lack this insertion and their *UBQ13* orthologs are possibly functional genes (Sun and Callis, 1993). *UBQ12* has an in-frame stop codon in the first repeat; all repeats of *UBQ8* and *UBQ9* have amino acid substitutions. These four are assumed to be pseudogenes, at least in the Columbia ecotype, and Genevestigator (Zimmermann et al., 2004) analysis indicating little or no expression supports this hypothesis (Dec 2013).

Ubiquitin-like proteins

After genome sequences became available, the existence of genes encoding ubiquitin-like (UBL) proteins were identified and their proteins' physiological roles investigated. Eight types of UBL proteins in Arabidopsis have been characterized; most are encoded by small gene families and six of the eight types are also covalent modifiers with analogous E1-like and E2-like activities catalysing attachment (Vierstra, 2012). The UBLs range from RUB1/2 with ~60% identity and identical in size to ubiquitin (Rao-Naik et al., 1998)] to the larger AUTOPHAGY 8 (ATG8) family of nine proteins with <20% identity to ubiquitin (Hanaoka et al., 2002; Thompson et al., 2005). Despite minimal sequence conservation, crystal structures of UBLs revealed strikingly similar structures to ubiquitin with similar β -grasp folds. The shape for this superfamily of proteins has subsequently been termed the "ubiquitin fold". The family of ubiquitin-like proteins in Arabidopsis and other plants was reviewed recently (Vierstra, 2012) as well as specifically the ubiquitin-fold proteins involved in autophagy (Vierstra, 2014), so these UBLs will be not be discussed here with the exception of the MUBs because of their unique non-covalent interactions with E2s.

Of note are a family of plasma membrane-localized UBLs called MEMBRANE UBIQUITIN (MUBs) (Downes et al., 2006). Prenylation of their C-terminal CAAX motif promotes membrane-localization. Arabidopsis contains six MUBs (Table 2), and these interact to varying degrees with one specific subset of E2 proteins (subfamily VI, see below). These proteins do not appear to function as protein modifiers. Rather, E2 interaction with MUBs localizes these E2s to the plasma membrane, suggesting a mechanism to increase local concentration of activated ubiquitin for subsequent transfer to substrates (Dowil et al., 2011).

Ubiquitin-like domain (UbLD)-containing proteins

In addition to UBL proteins (Vierstra, 2012), which are covalent modifiers, various predicted ORFs can be identified containing regions of similarity to ubiquitin, but lacking a complete ubiquitin coding region and are referred to as UBL domain-containing (UbLD) proteins (Upadhyaya and Hedge, 2003). It is likely that UbLD proteins do not function as covalent modifiers, but those that have been characterized are associated with the ubiquitin system (Table 2). Additional UbLD proteins are currently only predicted open

reading frames (Table 3). The structure of one uncharacterized UbLD protein (At2g32350, 1KAN) demonstrated that despite low sequence identity, UbLDs have a β -grasp fold and strong structural similarity to ubiquitin (Vierstra, 2012). Whether this structural near identity to ubiquitin is true for all UbLD proteins seems likely, but is unproven.

Four UbLD proteins are similar to budding yeast Rad23, RAD23a-d [RADIATION SENSITIVE, At1g16190, At1g79650, At3g02540, At5g38470, respectively, (Farmer et al., 2010; Lin et al., 2011)]. In these proteins, the N-terminal UbLD is required for interaction with the proteasome. They also contain one or more regions that bind preferentially to Lys-48 ubiquitin chains, referred to as UBA (ubiquitin associated) or UIM (ubiquitin interacting motif) domains. With these two domains, RAD23 proteins are proposed to provide a cross-linking function, bringing ubiquitinated proteins to the proteasome for degradation.

A 263 amino acid UbLD protein called ETERNALLY VEGETATIVE PHASE 1 (EVE1, At4g03350) contains an N-terminal 70 amino acid region with 36% identity (56% similarity) to ubiquitin, however without the C-terminal Gly-Gly ubiquitin residues required for conjugation. When EVE1 is overexpressed, plants exhibit morphologically distinct leaves and fail to produce an inflorescence meristem (Hwang et al., 2011). Its molecular function is unknown.

Six proteins from two subgroups of type II phosphoinositide (PI) 3/4 domain kinases possess one or two internal UbLDs (Table 2). This property appears to be plant-specific (Galvão et al., 2008). Two were characterized in detail and have protein kinase activity toward artificial substrates *in vitro*, so were renamed UBIQUITIN-LIKE DOMAIN KINASE 4 (UbdK γ 4, At2g46500) and UbdK γ 7 (At2g03890). In UbdK γ 4 with two UBL domains, the first domain, UBL1, has 78% similarity (35% identity), while the UBL2

Table 2. Characterized UBL Domain Containing Genes

AGI Number	Gene	Gene name	References and Comments
At1g16190	<i>RAD23a</i>	<i>RADIATION SENSITIVE</i>	Farmer et al 2010
At1g79650	<i>RAD23b</i>	<i>RADIATION SENSITIVE</i>	Farmer et al 2010
At3g02540	<i>RAD23c</i>	<i>RADIATION SENSITIVE</i>	Farmer et al 2010
At5g38470	<i>RAD23d</i>	<i>RADIATION SENSITIVE</i>	Farmer et al 2010
At2g12550	<i>NUB1</i>	<i>NEDD8 ULIMATE BUSTER</i>	Farmer et al 2010
At1g64470	<i>PI4Kγ2</i>	Phosphatidylinositol 4-kinase γ 2	Galvao et al 2008; 2 UBL domains
At5g24240	<i>PI4Kγ3</i>	Phosphatidylinositol 4-kinase γ 3	Galvao et al 2008; 2 UBL domains
At2g46500	<i>UbdKγ4 (PI4Kγ4)</i>	Ubiquitin-Like Domain Kinase; Phosphatidylinositol 4-kinase γ 4	Galvao et al 2008; 2 UBL domains
At1g26270	<i>PI4Kγ5</i>	Phosphatidylinositol 4-kinase γ 5	Galvao et al 2008; 1 UBL domain
At1g13640	<i>PI4Kγ6</i>	Phosphatidylinositol 4-kinase γ 6	Galvao et al 2008; 1 UBL domain
At2g03890	<i>UbdKγ7 (PI4Kγ7)</i>	Ubiquitin-Like Domain Kinase; Phosphatidylinositol 4-kinase γ 7	Galvao et al 2008; 1 UBL domain
At2g17190	<i>DSK2a</i>	<i>DOMINANT SUPPRESSOR OF KAR2</i>	Farmer et al 2010
At2g17200	<i>DSK2b</i>	<i>DOMINANT SUPPRESSOR OF KAR2</i>	Farmer et al 2010
At3g13235	<i>DD1</i>	<i>DNA DAMAGE INDUCIBLE</i>	Farmer et al 2010
At5g16090	<i>UBL1</i>	<i>UBIQUITIN LIKE</i>	pseudogene; Farmer et al 2010
At4g03350	<i>EVE1</i>	<i>ETERNALLY VEGETATIVE PHASE 1</i>	UBL domain-at N-terminus; lacks the GG; Huang et al 2011
At3g01050	<i>MUB1</i>	<i>MEMBRANE-ANCHORED UBIQUITIN-FOLD PROTEIN</i>	Downes et al, 2006; Dowil et al 2011
At5g15460	<i>MUB2</i>	<i>MEMBRANE-ANCHORED UBIQUITIN-FOLD PROTEIN</i>	Downes et al, 2006; Dowil et al 2011
At4g24990	<i>MUB3</i>	<i>MEMBRANE-ANCHORED UBIQUITIN-FOLD PROTEIN</i>	Downes et al, 2006; Dowil et al 2011
At3g26980	<i>MUB4</i>	<i>MEMBRANE-ANCHORED UBIQUITIN-FOLD PROTEIN</i>	Downes et al, 2006; Dowil et al 2011
At1g77870	<i>MUB5</i>	<i>MEMBRANE-ANCHORED UBIQUITIN-FOLD PROTEIN</i>	Downes et al, 2006; Dowil et al 2011
At1g22050	<i>MUB6</i>	<i>MEMBRANE-ANCHORED UBIQUITIN-FOLD PROTEIN</i>	Downes et al, 2006; Dowil et al 2011
At5g52060	<i>BAG1</i>	<i>BCL-2-ASSOCIATED ATHANOGENE</i>	Doukhanina et al, 2006
At5g62100	<i>BAG2</i>	<i>BCL-2-ASSOCIATED ATHANOGENE</i>	Doukhanina et al, 2006
At3g51780	<i>BAG4</i>	<i>BCL-2-ASSOCIATED ATHANOGENE</i>	Doukhanina et al, 2006
At5g62390	<i>BAG7</i>	<i>BCL-2-ASSOCIATED ATHANOGENE</i>	Doukhanina et al, 2006

domain has 68 and 34%, similarity and identity, respectively, to ubiquitin. Interestingly, the two UbLDs have only 61% similarity to each other with low similarity to the UbLD of UbDK γ 7 (Galvão et al., 2008). The UbDK γ 4 UBL1 domain is necessary and sufficient for *in vitro* binding to UBIQUITIN FUSION 1 (UFD1, At2g21270), a ubiquitin interacting protein. In contrast, both UBL1 and UBL2 domains were required for *in vitro* interaction with REGULATORY PARTICLE NON-ATPase 10 (RPN10, At4g38630), a subunit of the regulatory particle of the proteasome, which also interacts *in vitro* with UbDK γ 7. UbDK γ 4 phosphorylates UFD1 and RPN10 *in vitro*. The physiological consequences of interaction and phosphorylation are not known, but may provide insight into the regulation of these ubiquitin pathway components (Galvão et al., 2008).

A few other UbLD proteins have been characterized. Four of the chaperone proteins related to the human BCL-2-ASSOCIATED ATHANOGENE (BAG) family (At5g52060; At5g62100; At3g517890; At5g62390) contain an N-terminal UbLD of unknown function (Doukhanina et al., 2006). Other predicted proteins with UbLDs are only annotations (Table 3). In some cases, almost the entire predicted open reading frame shares similarity to ubiquitin (such as At1g53980 and At5g09340), and in other cases, the UbLD is a small part of a larger protein (such as in At5g42220 with 72 amino acids similar to ubiquitin in an 879-amino protein). A set of predicted proteins encoded by tandem loci each contain

a UbLD at their N-termini (At4g05230, At4g05240, At4g05250, At4g05260, At4g05270). Thus, there remain additional UbLD proteins to investigate.

UBIQUITINATION ENZYMES

Ubiquitin activating Enzyme (E1)

The first enzyme of the ubiquitin conjugation cascade is called ubiquitin activating enzyme or E1; the latter term refers to it historically having been the first characterized elution from a ubiquitin affinity column. E1 covalently binds to ubiquitin linked to a solid matrix in 5 mM ATP and elutes from the matrix with AMP and pyrophosphate [Figure 1, (Ciechanover et al., 1981; Ciechanover et al., 1982; Hershko et al., 1983)]. E1 catalyzes the “activation” of ubiquitin, which here refers to adenylation and then formation of a thioester (also termed thiolester) between the ubiquitin C-terminal carboxyl group and a single cysteinyl residue on E1 itself. This is a covalent linkage; hence E1 can be purified using ubiquitin affinity columns, but is unstable as the carbon of the carbonyl is electrophilic, readily subject to attack by nucleophiles. The enzymology of E1 was elucidated with the yeast and mammalian enzymes, but given the amino acid conservation of

Table 3. Predicted Proteins with UBL domains

AGI Number	Description
At1g53930	158 aa total; UBL domain aa 86-158; no LRGG
At1g53950	216 aa total; aa 50-124 and 141-212 are UBL domains; no GG
At1g53980	total 91 aa; 63% aa identity to 1-91 of At1g53950
At2g32350	total 242 aa; 75-146 UbLD domain, no GG
At3g06455	345 aa total; aa 9-81 is UBL domain; ~35% identical to ubiquitin; UBL ends in SLRGG; most similar to At4g01000; C-terminal 285-344 are 45% identical to splicing factor 3a
At4g01000	415 aa total; aa 9-81 is UBL domain; most similar to At3g06455; UBL domain ends in SLRGG; C-terminal 355-414 are 45% identical to splicing factor 3a
At4g02950	318 aa total; 36-107 aa identity to ub, no RLGG
At4g03360	284 aa total; 2-73 aa identity to ub, no RLGG
At4g03370	295 aa total; 1-72 aa identity to ub, no RLGG
At4g05230	206 aa total, 72 aa identity to ub- at N-terminus, no LRGG
At4g05240	197 aa total; 72 aa identity to ub at aa 58-129, no LRGG
At4g05250	318 aa total; 72 aa identity to ub- at N-terminus, no LRGG
At4g05260	259 aa total; UBL domain at 1-71, no GG
At4g05270	129 aa total; UBL domain at 1-72, no GG
At4g05310	415 aa total; UBL domain at 1-72, no GG
At5g09340	79 aa total has GG; 39% identical to ubiquitin; expressed?
At5g11080	373 aa total; UBL domain is 53% identical to At5g25270
At5g25270	658 aa total; 31% identical overall to At5g42220; UBL domain is 61% identical to At5g42220
At5g42220	879 aa total; 72 aa region at N-terminus with 39% identity to ubiquitin; no LRGG

Table 4. Ubiquitin E1s

AGI Number	Gene	Other Name	Comment	Reference
At2g30110	<i>UBA1</i>	<i>MOS5</i>	<i>UBIQUITIN ACTIVATING ENZYME; MODIFIER OF SNC1 5</i>	Hatfield et al 1997; Goritschnig et al 2007
At5g06460	<i>UBA2</i>		<i>UBIQUITIN ACTIVATING ENZYME</i>	Hatfield et al 1997

E1s, identical enzymology is likely identical for Arabidopsis E1. First, E1 binds ATP, and then the AMP moiety of ATP is ligated to ubiquitin's carboxyl terminus, forming a ubiquitin adenylate that remains noncovalently bound to E1 and releasing pyrophosphate. Second, ubiquitin is transferred to an active-site cysteine residue, exchanging the high-energy acyl phosphate anhydride linkage with AMP for a thioester bond. AMP then leaves the enzyme. Third, while one ubiquitin remains thioester-linked to E1, another ubiquitin adenylate is formed, filling the ubiquitin adenylate binding site left vacant after step two. This third step is not intrinsically necessary for ubiquitin's activation, but under physiological conditions E1 exists primarily as a ternary complex of ATP, ubiquitin, and E1~ubiquitin (Haas and Rose, 1982; Haas et al., 1982a; Haas et al., 1982b).

E1 activity is encoded in Arabidopsis by one of two related genes, *UBIQUITIN ACTIVATING 1 (UBA1, At2g30110)* and *UBA2 (At5g06460)* (Hatfield et al., 1997). UBA1 (1080 aa) and UBA2 (1077 aa) share 77% nucleotide identity and ~80% amino acid identity overall (Table 4). The N-termini are highly divergent, and even with many small indels introduced to maximize alignment, amino acid identity is only ~47% in the first ~70 amino acids. Both UBA1 and UBA2 activate ubiquitin and transfer it to several different E2s with equal efficiencies *in vitro* (Hatfield et al., 1997). Subtle differences are possible, because detailed and quantitative biochemical comparisons have not been pursued, nor all the E2s tested. Both *UBA1* and *UBA2* appear to be broadly expressed (Hatfield et al., 1997).

However, there is a report that the two E1 proteins might not have equivalent functions *in vivo*. An allele of *UBA1* was identified from a suppressor screen in a *snc1 npr1* double mutant background (Goritschnig et al., 2007). *SNC1* (suppressor of *npr1-1* constitutive 1, At4g16890) encodes a TIR-NB-LRR R-protein (for TOLL/Interleukin1-like-nucleotide binding-leucine rich repeat resistance protein). The *snc1* allele encodes a dominant constitutively active form of the protein and plants are dwarf, have elevated salicylic acid levels and enhanced disease resistance. The *UBA1* allele uncovered in the suppressor screen, called *mos5*, for *modifier of snc1*, resulted in an amino acid substitution followed by a 5 amino acid deletion before the last two amino acids at the UBA1 C-terminus, and suppressed both the *snc1* morphology and the constitutive expression of *SNC1*-induced pathogenesis-related genes. While it segregates as a recessive trait, whether it is a complete or reduced loss-of-function allele is not known. Interestingly, *mos5* alone in a wild type background exhibited enhanced disease susceptibility to a subset of pathogens.

In contrast, when a *UBA2* T-DNA allele with no detectable mRNA was investigated, it did not suppress any aspect of the *snc1* phenotype (Goritschnig et al., 2007). *uba2* plants were in-

distinguishable from wild type in growth and disease resistance assays, even against a pathogen that showed enhanced growth in the *uba1/mos5* mutant. This suggests that the level of E1 is sufficient in *uba2* from the other locus, *UBA1*, but not the reverse (that is, there is insufficient UBA2 in an *uba1* mutant) either quantitatively or in specific cell types, or that there is some biochemical difference between UBA1 and UBA2. Inspection of Genevestigator database (Zimmermann et al., 2004) indicates that *UBA1* is expressed at a higher level in a larger number of tissues/organs than *UBA2*, suggesting that without UBA1, E1 levels may not be sufficient when demand for ubiquitin activation is high, however, their relative *in vivo* roles need to be addressed directly. Given that loss of *UBA1* affects only a subset of the R-gene mediated resistance responses is intriguing and may be giving us clues as to which disease resistance pathway depends more critically on ubiquitination-dependent processes.

When *mos5* and *uba2* were crossed, no double homozygous F2 plants were recovered, suggesting that an *uba1 uba2* double mutant is not viable (Goritschnig et al., 2007). This is not surprising, given ubiquitin's central role in plant biology and that E1 activity is essential in budding yeast, and in any organism where E1 essentiality has been tested.

Ubiquitin carrier proteins (ubiquitin conjugating enzymes, UBCs, or E2s)

As with E1, the earliest E2s (most typically called ubiquitin conjugating enzymes [UBCs], also referred to as ubiquitin conjugases, ubiquitin carrier proteins, or in humans as UBEs) were biochemically characterized from rabbit reticulocyte lysates (Pickart and Rose, 1985) and have proven biochemically conserved in plants and animals. E2 accepts thioester-linked ubiquitin from E1 and similar to E1, carries ubiquitin thioester-linked on a cysteinyl E2 residue. E2 then transfers ubiquitin either to a substrate directly aided by an E3 or to a cysteinyl residue of the HECT or RBR types of E3s that then transfer ubiquitin to the substrate (see below). In all eukaryotes, gene families encode ubiquitin and UBL E2 activities. E2s for ubiquitin and most UBLs contain a conserved region of approximately 140 to 200 amino acids called the UBC domain (Inter-Pro IPR000608). The required cysteinyl residue for thioester formation is contained within this region.

There are 48 UBC domain-containing proteins (Bachmair et al., 2001; Kraft et al., 2005; Michelle et al., 2009) (see Table 5) in Arabidopsis [note: while DUDE 1.0 (<http://www.dude-db.org/>) identifies 85 Arabidopsis UBC proteins, manual inspection of the dataset reveals many redundant entries and a few errors, and

after their removal, results in the same total of 48]. Of the 48, three carry thioester-linked UBLs, not ubiquitin: 2 are RUB conjugating enzymes (RCE1, At4g36800 and RCE2, At2g18600) and one is a SUMO conjugating enzyme (SCE1, At3g57870), so while these UBL-specific enzymes function as E2s, they are not ubiquitin E2s, the focus of this chapter. Eight other UBC proteins lack the active site cysteine (Table 5) required for thioester formation, and so technically are not active by themselves, leaving 37 potential E2s that carry thioester-linked ubiquitin. Interestingly, the E2-like proteins in the autophagy pathway, ATG3 (At5g61500) and ATG10 (At3g07525) carrying via a thioester the UbLs ATG8 and ATG12, respectively (Li and Vierstra, 2012), are more diverged, and although by sequence similarity they lack a UBC domain, they share some structural similarities to the ubiquitin E2s (Yamada et al., 2007).

Thirty of the 37 Arabidopsis ubiquitin E2s have been tested for activity, and of those tested, 24/30 exhibited E2 activity (Table 5), demonstrating either a thioester linkage with ubiquitin or the ability to stimulate *in vitro* E3-dependent ubiquitination activity [summarized in (Kraft et al., 2005)]. The six E2s for which no activity was detected were tested for the ability to stimulate E3-dependent ubiquitination *in vitro*, not for the ability to form a ubiquitin thioester, which is the definition of an active E2. The reasons for their lack of *in vitro* ubiquitination activity are not clear, but likely result from either technical or biological reasons. In the latter case, an E2 could be active with only one or a few specific E3s, interacting proteins or substrates. For example, while UBC20 was inactive in *in vitro* ubiquitination assays (Kraft et al., 2005), it has all required catalytic residues and is 90% overall identical to the active UBC19 (Criqui et al., 2002). Based on these data, a reasonable prediction is that UBC20 is functional, and like UBC19, active with one specific E3 complex, the Anaphase Promoting Complex (APC).

For comparison, there are 10 ubiquitin-thioester active E2s in budding yeast and 29 in humans (from a total of 15 and 38 UBC domain-containing proteins, respectively) (Hochstrasser, 1996; Michelle et al., 2009; Kulathu and Komander, 2012). The crystal structure of *Arabidopsis thaliana* UBC1 has been published and is similar to the structures of yeast and mammalian E2s (Cook et al., 1992). The UBC domain is an α/β fold region of four α -helices and a four-stranded antiparallel β -sheet with a short variable helix near the catalytic cysteine (Wenzel et al., 2011b). The amino terminal part of this core domain, mostly the N-terminal helix (H1), provides a packing interface for E1 binding. Interestingly, the E1 and E3 interaction regions overlap, indicating that activated E2 must dissociate from E1 in order to interact with an E3 (Eletr et al., 2005). H1 and hydrophobic residues in two loops adjacent to H1 are required for interaction with a number of E3s, but some E2-E3 interactions are stabilized by salt bridges (Wenzel et al., 2011b). Likely additional mechanisms of interaction will be uncovered as more E2-E3 pairs are studied.

In the UBC domain of almost all E2s there is a conserved HPN (His-Pro-Asn) tripeptide about 10 residues N-terminal to the active site cysteine. The asparagine in the tripeptide serves a catalytic role by stabilizing the transient oxyanion formed during isopeptide bond formation (Wu et al., 2003). Substitution of the asparagine residue with glutamine severely reduced isopeptide bond formation, but had no effect on a transthiolation reaction to a HECT type E3 (see below, Wu et al, 2003). This result implicates

the asparagine residue in catalyzing amide bond formation specifically. The histidine serves a structural role, stabilizing these residues in a tight turn facilitated by the proline residue (Cook and Shaw, 2012). In addition, multiple E2s interact non-covalently with ubiquitin and ubiquitin-like domains in other proteins through the antiparallel β -sheet, referred to as the 'backside', and while an attribute of several E2s, the physiological significance of this interaction is not clear (Wenzel et al., 2011b).

Ubiquitin E2s can show considerable variation in overall length. They vary in the size of non-UBC regions, if present, with either N- or C-terminal extensions (Bachmair et al., 2001). In addition, a subset of E2s (in Arabidopsis, subfamily V) contains a 12-13 amino acid insertion within the UBC domain just C-terminal to the catalytic cysteine in loop 7, also called the acidic loop, which was demonstrated to be important for ubiquitin-ubiquitin Lys-48 chain formation in the related yeast E2, Ubc3/Cdc34 (Petroski and Deshaies, 2005).

UBC domain-containing proteins that lack the catalytic cysteine are also referred to as ubiquitin conjugating enzyme variants (UEVs). The best characterized in Arabidopsis is COP10 (At3g13550), identified from a screen for dark-grown seedlings with light-grown attributes. COP10 stimulates the thioester activity of several E2s as well as interacts with them *in vitro* (Lau and Deng, 2008) and interacts with E3 subunit protein DDB1 *in vitro* (Yanagawa et al., 2004), both suggesting that COP10 interacts with ubiquitin E2s to affect their activity in specific E3 complexes. Four UEVs, *UEV1A* to *UEV1D* (At1g2360, At1g70660, At2g36060, At3g52560, respectively) interact with one of two closely related E2s, UBC35 (UBC13A, At1g78870) and UBC36 (UBC13B, At1g16890), to form a heteromeric active E2, catalyzing ubiquitin-ubiquitin bonds via K63 (Wen et al., 2006; Wen et al., 2008). Based on studies with the orthologous proteins in yeast, the UEV proteins likely function to orient ubiquitins such that K63 ligation is favored (Wu et al., 2003).

An outstanding question remains, if ubiquitin E2s interact with the same E1 and in a conserved mechanism with E3s, why 37 ubiquitin E2 proteins in Arabidopsis? In addition to some genetic redundancy and specialized organ and/or subcellular locations, one answer is that multiple E2s have specialized biochemical functions, such as catalyzing specific ubiquitin-substrate or ubiquitin-ubiquitin linkages (such as the K63 chains described above for UBC35-UEV1) and/or have specific E3/substrate partners (such as UBC20 with the APC). Phylogenetic analyses comparing E2s from a number of species suggests that there is a core of seven ubiquitin E2 subfamilies in all eukaryotes (not including the conserved UBL E2 subfamilies), and most have multiple members; Arabidopsis and human contain an additional six ubiquitin E2 subfamilies, their conserved set is 13 "types" (Michelle et al., 2009). Whether these "types" delineate functionally distinct enzymes is not clear. Interestingly, from this analysis (Michelle et al., 2009), there do not appear to be plant-specific subfamilies. Focused studies on a few E2 subfamilies in Arabidopsis suggest some have specialized functions, which are detailed below.

UBC1-3 [subfamily III (At1g14400, At2g02760, At5g62540, respectively)] are an example of partial functional redundancy and specialized ubiquitination. UBC1 and 2 are 99% identical at the protein level and promoter GUS fusions show nearly identical patterns of expression. In contrast, UBC3 is 84% identical

Table 5. Ubiquitin E2 Proteins and their Interactors in ubiquitination

Gene Name	AGI Number	Subfam	Active?+	Other Names	Comments	References
A. Canonical Ubiquitin E2s						
UBC1	At1g14400	III	yes, TU		UBC1 and 2 required for H2B monoubiquitination <i>in vivo</i>	Cao et al 2008
UBC2	At2g02760	III	yes, TU		UBC1 and 2 required for H2B monoubiquitination <i>in vivo</i>	Cao et al 2008
UBC3	At5g62540	III	yes, U		E3 independent activity <i>in vitro</i> can interfere with E3-dependent assay	Kraft et al 2005; Wiborg et al 2008
UBC4	At5g41340	IV	yes, TU			
UBC5	At1g63800	IV	yes, U		E3 independent activity <i>in vitro</i> can interfere with E3-dependent assay	Kraft et al 2005; Wiborg et al 2008
UBC6	At2g46030	IV	yes, U			
UBC7	At5g59300	V	yes, T,U		forms free ubiquitin chains	van Nocker et al 1996
UBC13	At3g46460	V	yes, T,U		forms free ubiquitin chains	van Nocker et al 1996
UBC14	At3g55380	V	yes, T,U		forms free ubiquitin chains	van Nocker et al 1996
UBC8	At5g41700	VI	yes, TU			
UBC9	At4g27960	VI	yes, T			
UBC10	At5g53300	VI	yes, TU			
UBC11	At3g08690	VI	yes, TU			
UBC12	At3g08700	VI	nd			
UBC28	At1g64230	VI	yes, TU			
UBC29	At2g16740	VI	yes, U			
UBC30	At5g56150	VI	yes, U			
UBC15	At1g45050	VII	yes, T	ATUBC2-1	transfer to free lysine only	Bartling et al 1993
UBC16	At1g75440	VII	no, U			
UBC17	At4g36410	VII	no, U			
UBC18	At5g42990	VII	no, U			
UBC19	At3g20060	VIII	yes, T		not active with multiple RINGS in <i>in vitro</i> ubiquitination assays; APC E2 likely active as APC-specific E2	
UBC20	At1g50490	VIII	no, U			
UBC21	At5g25760	IX	nd	PEX4 (PEROXIN4)		
UBC22	At5g05080	X	yes, U		forms ubiquitin chains on UBC22 without an E3; strong E3 independent activity	Kraft et al 2005; Wiborg et al 2008
UBC23	At2g16920	XI	nd	PFU2 (PHO2 FAMILY UBIQUITIN)	mutant does not show Pi hyperaccumulation	Eidler 2010
UBC24	At2g33770	XI	nd	PHO2 (PHOSPHATE)	negatively regulates phosphate sensing	Aung et al 2006; Bari et al 2006; Chiou et al 2006
UBC25	At3g15355	XI	nd	PFU1	mutant does not show Pi hyperaccumulation	Eidler 2010
UBC26	At1g53025 (incorrect as At1g53020 in TAIR v10)	XI	no, U	PFU3	There are 3 predicted genes in tandem each with a UBC-like domain. No evidence for expression of At1g53023 or At1g53020. Expressed gene is At1g53025, which should correspond to UBC26; mutant does not show Pi hyperaccumulation	Kraft et al 2005; Eidler 2010
UBC27	At5g50870	XII	yes, T		contains C-terminal UBA domain	
UBC31	At1g36340	XIII	nd		vacuolar-localized from proteomic study	Carter et al 2004

(Continued)

Table 5. (continued).

Gene Name	AGI Number	Subfam	Active?+	Other Names	Comments	References
A. Canonical Ubiquitin E2s (continued)						
UBC32	At3g17000	XIV	yes, T		contains predicted C-terminal TM domain; GFP fusion ER-localized	Kraft et al 2005; Cui et al 2012
UBC33	At5g50430	XIV	nd		contains predicted C-terminal TM domain	
UBC34	At1g17280	XIV	yes, U		contains predicted C-terminal TM domain	
UBC35	At1g78870	XV	yes, TU	UBC13A	UBC35 nomenclature is preferred because of prior publication of UBC13 (above)	Kraft et al 2005; Lau et al 2009
UBC36	At1g16890	XV	yes, TU	UBC13B	UBC36 nomenclature is preferred because of prior publication of UBC13 (above)	
UBC37	At3g24515	XVI	no, U			
B. UBC domain-containing proteins lacking active site cysteine						
COP10	At3g13550			FUS9, EMB144, CIN4	constitutive photomorphogenic, interacts with DDB1 and DET1; enhances K63 chain formation catalyzed by UBC13/UEV1	Yanagawa et al 2004
UEV1A	At1g23260			MMZ1, MMS ZWEI HOMOLOGUE	interacts with UBC35/36	Wen et al 2008
UEV1B	At1g70660			MMZ2	interacts with UBC35/36	Wen et al 2008
UEV1C	At2g36060			MMZ3	interacts with UBC35/36	Wen et al 2008
UEV1D	At3g52560			MMZ4	interacts with UBC35/36	Wen et al 2008
	At2g32790					no information
ELC	At3g12400			Vps23/ELC	weak identity to UBC domain, lacking HPN has HAH, binds ubiquitin	
ELC-Like	At5g13860			ELC-like	most similar to yeast Vps22/Smp22 and human TSG101	

+ activity assays: ubiquitin thioester formation (T) or stimulation of ubiquitination in vitro (U), data from Kraft et al 2005 and references therein if not noted

to UBC1/2 with slight differences in expression (Sullivan and Vierstra, 1993; Thoma et al., 1996; Cao et al., 2008). A loss-of-function mutant in *UBC2* or *UBC3* does not differ from wild-type in terms of flowering time, while *ubc1-1* shows either a slightly decreased (Xu et al., 2008; Gu et al., 2009) or no change in flowering time (Cao et al., 2008). The double *ubc1 ubc2* has a much earlier flowering time, indicating both contribute to the same process. However, loss of *UBC3* had no effect on flowering time in *ubc1* or *ubc2* backgrounds, suggesting that *UBC3* does not contribute (Cao et al., 2008). The *ubc1 ubc2 ubc3* triple shows additional defects compared to *ubc1 ubc3* and *ubc2 ubc3* double mutants, including dwarfism and reduced fertility (Cao et al., 2008), and reduced seed dormancy and chlorophyll (Liu et al., 2007), implying that all three function redundantly in these processes.

The specific phenotypes of the *ubc1 ubc2* double and the *ubc1 ubc2 ubc3* triple likely result from their biochemical specialization. Both UBC1 and UBC2 interact in yeast two-hybrid assays with

the two closely related RING-type E3s called HUB1 (*HISTONE MONOUBIQUITINATION1*, At2g44950, also called REDUCED DORMANCY 4, RDO4) and HUB2 (At1g55250) [unfortunately UBC3 was not tested in these assays (Cao et al., 2008)], and together are responsible for accumulation of monoubiquitinated histone 2B (H2Bub1) because single *hub* and *ubc1 ubc2* double mutants have very little or no detectable H2Bub1 (Liu et al., 2007; Cao et al., 2008; Xu et al., 2008; Gu et al., 2009). H2B monoubiquitination is not linked to proteolysis, rather it promotes histone H3 methylation; both histone modifications are associated with active genes. In *ubc1 ubc2* double and both *hub* single mutants, mRNAs for MAD4 (MADS AFFECTING FLOWERING 4, At5g65070) and MAD5 (MADS AFFECTING FLOWERING 5, At5g65080), two FLOWERING LOCUS C relatives are reduced and FLOWERING LOCUS T (FT, At1g65480) expression is 3–4 fold higher; these gene expression changes are consistent with their early flowering phenotype (Cao et al., 2008; Xu et al., 2008). Significantly, the *hub ubc1 ubc2* triple mutant did not differ in flow-

ering time from the *ubc1 ubc2* double, indicating these E2s and E3s function in the same pathway (Gu et al., 2009).

Additional E2 biochemical diversity is reflected in the nature of ubiquitin-ubiquitin chain linkages synthesized and whether free chains, unlinked to a target protein, can be formed either with or without an E3, although the biological significance of free chains is unknown. Subfamily V, consisting of UBC7, UBC13 and UBC14 (At5g59300, At3g46460, At3g55380, respectively) catalyzes E3-independent ubiquitin-ubiquitin linkages untethered to a substrate (Van Nocker et al., 1996b). Also UBC22 (At5g05080), the sole member of subfamily X, catalyzes ubiquitin chain assembly *in vitro* without an E3 (Kraft et al., 2005). Unfortunately, the *in vivo* roles for these E2s are unknown.

The largest subfamily, subfamily VI, contains eight members (UBC8-12, UBC28-39, see Table 5) with quantitative differences in expression (Kraft et al., 2005) and the current consensus is that the members are biochemically equivalent, although this is not proven. While *UBC12* and *UBC30* have low levels of expression, *UBC8* and *UBC10* are in the abundantly expressed gene class. This subfamily is most similar to human UbcH5 (Ube2D1), a promiscuous E2 that functions *in vitro* with a number of E3s (Marblestone et al., 2013). Similarly, UBC 8-11 exhibit nearly identical abilities to stimulate substrate-independent ubiquitination of a variety of RING type E3s *in vitro* (Kraft et al., 2005). UBC8 is able to catalyze ubiquitination with a HECT E3, a distinct E3 type (see below), while UBC1, UBC4 and UBC7, members of other subfamilies, were not (Bates and Vierstra, 1999). For these reasons, members of this E2 subfamily are often referred to as 'generic' E2s and are the E2s that should be utilized in tests for E3 activity in the absence of any other information.

Another potentially redundant subfamily with a possibly unique biochemical function is subfamily VII, consisting of UBC15-18 (At1g45050, At1g65440, At4g36410, and At5g42990, respectively). These E2s are most closely related to human Ube2W, an E2 that catalyzes addition of one ubiquitin to the N-terminal amino group (α -NH₂) of substrates (Scaglione et al., 2013; Tatham et al., 2013). Referred to as linear ubiquitination, this process is distinct from another linear ubiquitination machinery, also in animals, an E3 complex called LUBAC [linear ubiquitin chain assembly complex (Tokunaga and Iwai, 2012)]. Neither linear ubiquitination by a dedicated E2 or specialized E3 has been described in plants to date. But UBC15-18 contain all the amino acid differences in Ube2W that distinguish Ube2W from the "generic" E2s (such as human Ube2D1 and AtUBC8) in catalyzing ϵ -NH₂ lysine ubiquitination, making it very tempting to speculate that Arabidopsis UBC15-18 have the same biochemical activity as human Ube2W. Detecting classic thioester activity for UBC15-18 has been challenging, with transfer of ubiquitin to free lysine as the only *in vitro* activity detected for UBC15 (Bartling et al., 1993; Kraft et al., 2005). Again, this difficulty suggests that subfamily VII functions with specific E3s to transfer a single ubiquitin to the N-terminus of select proteins, a reaction not strictly assayed for in the past.

UBC32-34 (At3g17000, At5g50430, At1g17280, respectively), subfamily XIV, are distinguished by the presence of a predicted C-terminal transmembrane domain and UBC32-GFP localizes to ER membranes (Cui et al., 2012b). UBC32 interacts *in vivo* in *N. benthamiana* transient assays with a RING-type E3, named DOA10B (At4g32670) in a split luciferase assay. This E3 is most similar to yeast Doa10 (Degradation Of Alpha2), an ER-localized

ligase important for degradation of ER-localized misfolded proteins (ERAD, ER Associated Degradation). Clues to UBC32's function came from multiple observations. First, *UBC32* mRNA increases after application of reagents that cause ER stress. Second, *UBC32* loss-of-function mutants and over-expression seedlings are hypo- and hyper-sensitive, respectively, to exogenously applied agents that cause ER stress (Cui et al., 2012a). Finally, use of an altered form of the brassinosteroid receptor, BRI1, the bri1-9 allele, which has reduced PM localization due to ER-retention and subsequent degradation via ERAD (Hong et al., 2008) helped define an *in vivo* role for UBC32. When bri1-9 is expressed in a *ubc32* loss-of-function background, its abundance is increased and brassinosteroid signaling is enhanced, suggesting that suppression of ERAD via loss of UBC32 leads to increased trafficking of the mutant receptor to the cell surface (rather than degradation), placing UBC32 functionally in the ERAD pathway (Cui et al., 2012b). *ubc32* plants have additional phenotypic differences from wild type; they are salt and ABA hypo-sensitive as seedlings; however the former is related to its effect on BL signaling, so UBC34's involvement in other pathways is not known (Cui et al., 2012b). The roles for UBC33 and UBC34, E2s related to UBC32, are currently unknown.

One member of subfamily XI (UBC23-26; At2g16920, At2g33770, At3g15355, At1g53020, respectively) appears to have a unique biological function. *PHOSPHATE 2 (pho2)/ubc24* loss-of-function mutants hyper-accumulate inorganic phosphate in leaves leading to necrosis, a phenotype mirrored by constitutive over-expression of miRNA399 (Aung et al., 2006; Bari et al., 2006). miRNA binding sites in *PHO2* indicate their reciprocal regulation is direct. *PHO2* localizes to membranes, and interacts with *PHO1*, a transmembrane Pi translocator that hyper-accumulates in *pho2* (Liu et al., 2012). While there are 2 *PHO2*-like E2s, their single loss-of-function mutants do not have altered Pi accumulation (Eifler, 2010).

UBC19 (At3g20060) and UBC20 (At1g50490) constituting subfamily VIII, are likely functionally redundant E2s whose E3 is the Anaphase Promoting Complex (APC), a multi-subunit E3 responsible for mitotic cyclin degradation (Criqui et al., 2002). UBC19 complements a fission yeast strain defective in its APC E2, providing functional evidence that this Arabidopsis E2 is specialized for ubiquitination catalyzed by the APC.

The sole member of subfamily VII, UBC27 (At5g50870), is unique in containing an UBA domain. It is most similar to human Ube2K. *In vitro* ubiquitination assays with E1, Ube2K and ubiquitin suggest that the UBA domain directs Lys-48 ubiquitin linkage formation because Ube2K without the UBA domain is active in synthesis of other ubiquitin-ubiquitin linkages (Wilson et al., 2011).

UBC21 (At5g25760, subfamily IX) is specialized for ubiquitination in peroxisome maintenance. Better known as PEROXIN 4 (PEX4), *pex4/ubc21* mutants were first identified in Arabidopsis due to their resistance to indolebutyric acid (IBA), an auxin analog that requires peroxisomal function to process it to the major auxin indoleacetic acid (IAA). Since exogenous IAA reduces root elongation, *pex4* mutants exhibited longer roots in the presence of IBA (Zolman et al., 2005). Degradation of a resident glyoxysomal protein isocitrate lyase is dependent on PEX4, suggesting that removal of glyoxylate cycle enzymes during the transition from glyoxysomes to peroxisomes includes export from peroxisomes and ubiquitination (Zolman et al., 2005; Lingard et al., 2009). Yeast Pex4 is tethered to the peroxisomal membrane via interaction

with an integral membrane protein Pex22, and similarly AtPEX4/UBC21 interacts with the Arabidopsis homolog of Pex22, PEX22 (At3g21865) (Zolman et al., 2005). In yeast, three E3 ligases localized to the peroxisomal membrane are required for the monoubiquitination of Pex5, the main protein import machinery, which recycles back to the cytosol for continued import (Platta et al., 2014). Loss-of-function mutants in each of three Arabidopsis E3s with similarity to the yeast E3 proteins, PEX2/TED3 (At1g79810), PEX10 (At2g26350), PEX12 (At3g04460) are embryo lethal, indicating an essential function for these E3s and suggesting that the receptor cycling pathway is present in plants (Hu et al., 2002; Schumann et al., 2003; Sparkes et al., 2003; Fan et al., 2005).

Complexity in ubiquitination derives from the extent and nature of ubiquitin chains

Proteomic analyses have revealed a diversity of ubiquitin-ubiquitin linkages in Arabidopsis (Kim et al., 2013). One of the most abundant ubiquitin-ubiquitin linkages is via K48 and K48 chains target proteins to the proteasome in many systems by interacting with subunits of the proteasome (Fu et al., 1998).

Less is understood regarding the roles of other ubiquitin chains in Arabidopsis. As mentioned above, UBC35 and UBC36 interact with the E2-like proteins UEV1-4 to catalyze ubiquitin chains specifically via K63. UBC35 interacts in yeast 2H assays with the E3s RING DOMAIN LIGASE 1 (RGLG1) and RGLG2 (At3g01650 and At5g14420, respectively), and RGLG2 stimulates K63 chain formation *in vitro* (Yin et al., 2007). A generic E2, UBC9, does not substitute in these assays (Yin et al., 2007). Chain specificity is typically determined by use of substituted ubiquitins; in this case, chain formation was suppressed in assays containing ubiquitin with K63 substituted with an arginine (UbK63R). A loss-of-function mutant in UBC34 exhibited reduced branched root hairs under iron depleted conditions and *ubc34 ubc35* roots showed shortened root hairs (Li and Schmidt, 2010). Lysine-63 chains have been implicated in DNA damage responses based on the hypersensitivity of *uev1D* mutants to DNA damaging agents (Wen et al., 2008). However, K63 chains are also implicated in regulating apical dominance and iron deficiency response and drought stress, based on altered responses of the *rglg1 rglg2* double mutant, however, definitive connection to K63 chains specifically in these processes remains to be established (Yin et al., 2007; Li and Schmidt, 2010; Cheng et al., 2012). It could be that, with different E2s, RGLG proteins catalyze other ubiquitin-ubiquitin linkages. The possible roles for K63 linkages have been reviewed recently (Pan and Schmidt, 2014; Tomanov et al., 2014).

The plasma membrane-localized auxin transport efflux carrier PIN-FORMED 2 (PIN2, At5g57090) is ubiquitinated with K63 chains (Leitner et al., 2012). The extent of ubiquitinated PIN2 is reduced, but not eliminated, in an *rglg1 rglg2* background, suggesting that these E3s contribute to PIN2 ubiquitination, but not exclusively (Leitner et al., 2012). High levels of auxin reduce PIN2-VENUS levels, and increased vacuolar fluorescence is observed, indicating that PIN2 is internalized and targeted to the vacuole (Leitner et al., 2012).

Even less is known about other chain types in Arabidopsis. *In vitro*, addition of ubiquitin K29R variant slowed *in vitro* degradation

of a gibberellic acid (GA) regulated transcription factor, REPRESSOR OF *ga1-3* (RGA, At2g01570), suggesting that K29 chains play a role in degradation (Wang et al., 2009). Our current understanding of the roles of various ubiquitin chains in plant biology has been reviewed recently (Walsh and Sadanandom, 2014).

Ubiquitin E3 ligases-general

The third type of activity in the ubiquitin conjugation cascade has been coined E3 or ubiquitin ligase and facilitates the transfer of ubiquitin to the substrate protein (Figure 4). E3s are a large and diverse group of proteins. They can be divided into three mechanistic types based on whether they carry thioester-linked ubiquitin. The HECT-type E3s require a cysteine residue for activity that is the site of a thioester-linked ubiquitin intermediate. Thus in these E3s, ubiquitin is passed in a transthioesterification reaction from the E2 to the E3 prior to transfer to the substrate. In the RING and U box types, the E2~ubiquitin noncovalently interacts with the E3 via a conserved domain and participates in ubiquitin transfer as part of an E2/E3/substrate complex. Recently, a third hybrid type has been described in mammals, and relatives are present in Arabidopsis. Initially referred to as the RBR (RING between RING) type, these E3s interact with the E2~ubiquitin as in the RING/U box type, but then transfer ubiquitin to an RBR cysteinyl residue prior to transfer and transfer ubiquitin to proteins in a HECT-type mechanism.

The RING Type E3s- General comments

The RING (REALLY INTERESTING NEW GENE) type of E3 ligases shares the RING domain, a ~40-60 amino acid region containing an octet of spatially conserved cysteine and histidine residues that bind two zinc (Zn) atoms. These RING domains differ from other Zn-binding "fingers" such as those of Zn finger transcription factors in the spacing of the Cys/His residues, resulting in a structural difference between them. In E3 RING domains, the linear order of Cys/His does not translate into a linear order of chelating or metal ligand (ml) residues. Numbered from the N-terminus to the C-terminus of the polypeptide chain ml1 and ml2 together with ml5 and ml6 bind the first zinc atom, whereas ml3 and ml4 together with ml7 and ml8 bind the second zinc ion, forming what is termed a cross-brace secondary structure.

Bioinformatic analyses identify 490 Arabidopsis proteins containing a RING domain (based on TAIR10 annotations) proposed to function as E3s [(Stone et al., 2005) and Callis, unpublished]. Curiously, members of the CELLULOSE SYNTHASES (CesA) family also contain a RING domain with the eight conserved ml residues. In cotton CesA, the RING domain serves as a redox-regulated dimerization domain (Kurek et al., 2002). Many other uncharacterized proteins with RING domains do exhibit E3 activity *in vitro*, suggesting that the presence of this domain likely identifies an E3 ligase with a few possible exceptions as mentioned above. Even proteins with substitutions in the zinc binding residues or with slightly altered spacing are active in ubiquitin transfer (Stone et al., 2005). Given the large number of RING proteins, it is not possible to discuss them all. This article will highlight new insights into the biological functions regulated by RING-type E3s

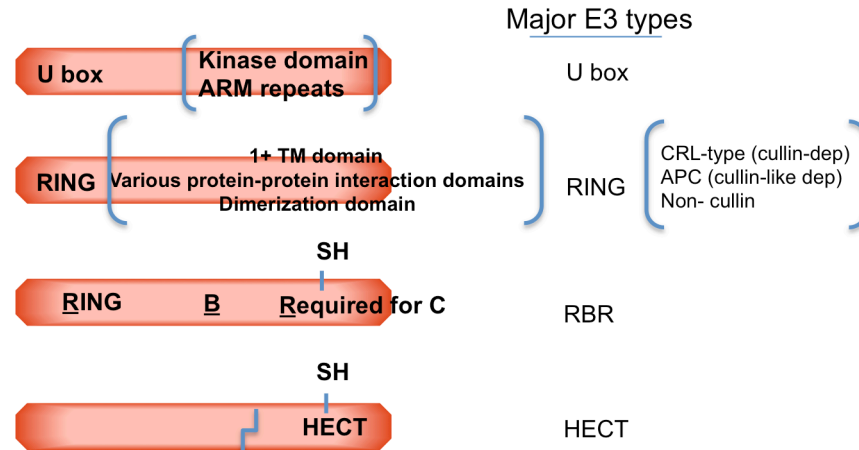

Figure 4. Diagrammatic representation of E3 types.

From top, U box-, RING-, RBR-, HECT-type E3s contain their respective characteristic domains. RING, for Really Interesting New Gene; HECT, for Homology to E6-AP Carboxy Terminus. The RBR type E3 initially referred to the term RING1-In Between RING- RING2. More recently, a change in nomenclature (but not abbreviation) was suggested to more accurately represent the biochemical activities of the domains: with RBR representing an abbreviation for: RING- Benign catalytic-Required for catalysis. E2~Ub interacts with U box and RING domains and a region in HECT E3s upstream of the catalytic SH. The -SH of RBR- and HECT-type E3s is the site of ubiquitin thioester present as an intermediate in ubiquitination of substrates. Many, but not all, U box proteins have kinase or multiple ARM repeats. RING proteins are more diverse; subsets contain 1 or more transmembrane domains (TM), other characterized protein-protein interaction domains and/or other regions implicated in homo- or hetero-oligomerization. The bent line in HECT-type E3 indicates that these proteins are typically very large. The RING and U box domains may be located near the N-terminus, internally or at the C-terminus; the HECT domain is typically at the C-terminus. RING-type E3s include the multiple subunit CRL (for cullin-RING-ligase) types consisting of a RBX (RING BOX) type RING protein, a scaffold cullin protein (one of 3 types in Arabidopsis) and one or more substrate specificity subunits. The APC (anaphase promoting complex) E3 contains a RING protein (APC11) and a cullin-like protein in addition to other subunits.

(Table 6). Please note that this discussion does not include processes regulated by multi-subunit cullin-based E3s nor the APC, each of which includes a RING protein.

The E3 RING domain serves as the major E2-interacting region. After the E2~Ub binds to the RING domain, reactivity of the E2~Ub thioester bond is further de-stabilized, thus promoting attack by an amino group (Das et al., 2009; Das et al., 2013). The one exception is a subgroup of RING proteins, the RBR proteins, described below. Thus, the RING domain is thought to function as an allosteric activator, weakening the E2~Ub linkage prior to transfer. Based on studies with animal RING proteins, additional residues outside of the RING domain influence E2 interactions and activity, but have yet to be confirmed for any Arabidopsis RING E3.

Subgroups of RING domains have been identified based on which ml residue (Cys or His) is present, whether there are substitutions in these conserved residues, or if some slight differences in spacing are present (Kosarev et al., 2002; Stone et al., 2005). There is more variation tolerated in these parameters than first appreciated. Histidine is present at ml4 and 5 in RING-H2 (also called C3H2C3) proteins but present only at ml4 in RING-HC (C3HC4) proteins, with all other ml residues being cysteines. However, there are additional variations, including those with no ml histidines at all (RING-C2), proteins with Asp instead of Cys/His at ml5 (RING-D), a few with ml residues replaced with Ser (RING-S/T such as found in DNF, DAY NEUTRAL FLOWERING, At3g19140) and others with a C4HC3 configuration combined with additional amino acids between ml4 and 5 (RINGv type). At

least one member from each of these types was shown to be active as an E3 *in vitro* (Stone et al., 2005; Morris et al., 2010).

RING domains can be additionally characterized by the nature of other protein-protein interaction motifs and have been divided into 30 different groups using this criterion (Stone et al., 2005). For example, the Arabidopsis RING SINA (Seven in Absentia) proteins, named after *Drosophila* Sina, share a ~200 amino acid conserved C-terminal region and consist of sixteen members: SINAT1-SINAT5 (SINA in Arabidopsis thaliana) and SINA-LIKE 1-11. The best characterized is SINAT5 (At5g53360), which binds to and ubiquitinates the transcription factor NAC1 (petunia NAM and Arabidopsis ATAF1, ATAF2, and CUC2 domain-containing, At3g15170) *in vitro* and regulates NAC1 abundance *in vivo* (Xie et al., 2002).

Other protein-protein interaction motifs or uncharacterized conserved regions shared among RING proteins are likely to have functional significance; these roles, which likely include substrate interaction and intracellular localization, have not yet been discovered for many RINGs.

“Complex” RING-type E3s

Several RING E3 ligases are components of characterized multi-subunit complexes. The most notable example is the ~16 kDa RING protein RBX1a (RING BOX 1, At5g20570), present in the cullin-based E3 ligases (CRLs for cullin-RING ligases), whose structural organization is highly conserved between plants and

Table 6. RING proteins described in text

AGI Name	Name	Hypothesized Biological Role	Organization	Comments	References
At5g53360	SINAT5	Regulates NAC1 levels; affects lateral roots	homodimerizes, dimerization hypothesized to be required for activity because inclusion of inactive form in activity assays reduces activity	interacts with NAC1 in vitro; ubiquitinates NAC1 in vitro, regulates NAC1 levels in vivo	Xie et al 2002
At5g57740	XBAT32	ethylene production; lateral root production	unknown	interacts with ACS4 and 7; ubiquitinates ACS4 and 7 in vitro	Nodzon et al 2004; Prasad et al 2010; Lyzenga et al 2012
At4g14365	XBAT34		unknown		
At3g23280	XBAT35	hook curvature hypersensitivity to added ACC	unknown		Carvalho et al 2012
At5g44280	RING1a	gene silencing	in Polycomb Complex 1 (PRC1)	interacts with itself and RING1b	Xu and Shen 2008
At1g03770	RING1b	gene silencing	in PRC1	interacts with RING1a	Xu and Shen 2008
At2g30580	BMI1a	gene silencing	in PRC1		Bratzel et al 2010
At1g06770	BMI1b/DRIP1	gene silencing/stress response	in PRC1		Bratzel et al 2010; Qin et al 2008
At3g23060	BMI1c/DRIP2	presumed monoubiquitination of H2A gene silencing?/ stress response	in PRC1		Bratzel et al 2010; Qin et al 2008
At3g05870	APC11	cell cycle regulation; cyclin degradation	in APC/cyclosome		Heyman and De Veylder, 2012
At5g20570	RBX1a	many	in CRLs		Gray et al 2002; Lechner et al 2002
At3g42830	RBX1b	unknown	unknown		Gray et al 2002; Lechner et al 2002
At3g19140	DNF	repressor of flowering in short days	unknown		Morris et al 2010
At2g44950	HUB1	gene activation	interacts with HUB2, HUB1/HUB2 heteromer likely active form	monoubiquitination of H2b lost in hub1; interacts with the E2s UBC1 and UBC2	Liu et al 2007; Cao et al 2008; Xu et al 2008; Gu et al 2009
At1g55250	HUB2	gene activation	interacts with HUB1, HUB1/HUB2 heteromer likely active form	monoubiquitination of H2b lost in hub2; interacts with the E2s UBC1 and UBC2	Liu et al 2007; Cao et al 2008; Xu et al 2008; Gu et al 2009
At4g32670	DOA10B	ERAD		interacts with E2 UBC32	Cui et al, 2012
At3g01650	RGLG1	iron homeostasis, DNA damage response, apical dominance, drought stress	unknown	K63 chain formation with UBC35/36 and a MMS protein, only double rglg1 rglg2 has phenotypic differences from WT	Yin et al 2007; Li and Schmidt, 2010; Cheng et al 2012

Table 6. (continued)

AGI Name	Name	Hypothesized Biological Role	Organization	Comments	References
At5g14420	RGLG2	iron homeostasis, DNA damage response, apical dominance, drought stress	unknown	K63 chain formation with UBC35/36 and a MMS protein, only double rglg1 rglg2 has phenotypic differences from WT	Yin et al 2007; Li and Schmidt, 2010; Cheng et al 2012
At5g63970	RGLG3	jasmonate-mediated wound response	unknown	only double rgl31 rglg4 has phenotypic differences from WT	Zhang et al 2012
At1g79380	RGLG4	jasmonate-mediated wound response	unknown	only double rgl31 rglg4 has phenotypic differences from WT	Zhang et al 2012
At2g32950	COP1	photomorphogenesis, flowering, etc	with SPA proteins, also in CUL4-based CRL	yes, ubiquitinates HY5, CO, PhyA, many genetic interactions	Deng et al 1992; Holm et al 2002; Lau and Deng 2012
At2g42160	BRIZ1	germination	interacts with BRIZ2, heteromer likely active form	yes	Hsia and Callis, 2010
At2g26000	BRIZ2	germination	interacts with BRIZ1, heteromer likely active form	yes	Hsia and Callis, 2010
At4g25230	RIN2	disease resistance	interacts with RIN3		Kawasaki et al 2005
At5g51450	RIN3	disease resistance	interacts with RIN2		Kawasaki et al 2005
At2g35000	ATL9	disease resistance	ER-localized		Berrocal-Lobo et al 2010
At5g10380	ATL55/RING1	disease resistance; abiotic stress	PM-localized		Lin et al 2008
At1g49230	ATL78	abiotic stress	PM-localized		Kim et al 2013
At2g17750	ATL26/NIP1	chloroplast development	thylakoid		Azevedo et al 2008
At2g17730	ATL25/NIP2	chloroplast development	thylakoid		Azevedo et al 2008
At5g27420	ATL31/CNI1	C/N sensing			Sato et al 2011
At3g05200	ATL6	C/N sensing			Sato et al 2011
At3g24800	PRT1	N-end rule		targets proteins with aromatic N termini	Bachmair et al 1986; Potuschak et al 1998; Sary et al 2003
At5g02310	PRT6	N-end rule, oxygen and NO sensing		ubiquitinates proteins with arginylated N-termin	Garzon et al 2007; Licausi et al 2011; Weits et al 2014; Gibbs et al 2014
At1g63900	SP1/DAL1	chloroplast protein homeostasis		ubiquitylates TOC complex in chloroplast envelope	Ling et al 2012; Vindhya et al 2011
At1g05880	ARI12	UV response			Lang-Mladek et al 2012
At5g63730	ARI14	pollen development		hypothesized to be inactive based on absence of 2 ml residues	Ron et al 2010

animals (Gray et al., 2002; Lechner et al., 2002). The CRLs are considered “complex” RING-type E3s because E2 interaction and substrate binding occur in different subunits tethered together into a single complex by an elongated cullin-type protein scaffold (Hua and Vierstra, 2011). In *Arabidopsis*, RBX1a (and possibly a second protein RBX1b, At3g42830, although its expression is much more restricted) functions in CRLs as the E2 docking site. RBX1a is considered an essential gene; no homozygous complete loss-of-function seedlings have been isolated (Gray et al., 2002; Lechner et al., 2002). Down-regulation of RBX1a generates dwarf plants with poor fertility (Gray et al., 2002; Lechner et al., 2002), indicating the central role that CRLs play in plant growth and development (Hua and Vierstra, 2011). CRLs containing the same RBX protein can differ in the substrate interacting module and are the subject of a separate article in this series (Choi et al., 2014).

Similarly, the 84 amino acid RING-H2 protein APC11 (Anaphase Promoting Complex, At3g05870) serves a similar function in the essential mega-E3 complex, the APC, which consists of ~10 different core proteins (including APC11), plus a variable number of regulatory proteins (Heyman and De Veylder, 2012). As in animals and yeast, *Arabidopsis* APC controls cell division by ubiquitinating a number of cell cycle regulatory proteins; known substrates include cyclins as well as the dsRNA-binding protein DRB4 [DOUBLE-STRANDED-RNA-BINDING PROTEIN 4, At3g62800 (Marrocco et al., 2012)]. Likely additional proteins are substrates of the *Arabidopsis* APC (Genschik et al., 2014).

Another example of a RING-containing complex is the PRC1 (polycomb repressive complex 1) that catalyzes monoubiquitination of histone 2A. PRC1 interacts with chromatin containing trimethylated K27 histone 3, the methylations placed by PRC2 (Molitor and Shen, 2013), although a strict hierarchical relationship between PRC2 and PRC1 has been questioned recently (Yang et al., 2013; Calonje, 2014). Together, these histone modifications act as repressive marks that silence gene expression. *Drosophila* PRC1 consists of four subunits, two of which are RING-type E3s. Homologs of these proteins have been identified in *Arabidopsis* and function in the plant PRC1-like complex [reviewed in (He et al., 2013; Molitor and Shen, 2013; Feng and Shen, 2014)]. *Arabidopsis* RING1a (At5g44280) and RING1b (At1g03770) most closely resemble *Drosophila* PRC1 subunit Ring1 and BMI1a (At2g30580), BMI1b (At1g06770) and BMI1c (At3g23060) most closely resemble the *Drosophila* PRC1 RING protein Psc (Posterior sex combs). Consistent with the hypothesis that one copy of either RING1a or RING1b is present in PRC1, RING1a and RING1b appear to be functionally redundant, since single mutants do not differ from wild type, while the double *ring1a ring1b* mutant is completely sterile with vegetative organs such as cotyledons and leaves developing ectopic meristems concomitant with increased *KNOX* (*KNOTTED-like homeobox*) gene expression (Xu and Shen, 2008; Chen et al., 2010). Similarly, embryonic phenotypes were observed in *bmi1a bmi1b* seedlings while the single mutants were wild type (Bratzel et al., 2010). The effects of loss of BMI1c were not evaluated in this study, however *BMI1c* may not provide significant activity because *BMI1c* mRNA is >20-fold lower than *BMI1a* or *BMI1b* (Bratzel et al., 2010). RING1a, RING1b, BMI1a and BMI1b were individually active in monoubiquitinating H2A.1 *in vitro*, while an H2A.1 with Lys-121 substituted with Arg was not modified (BMI1c was not tested). Ubiquitination of *in vivo* expressed epitope tagged H2A.1 is greatly reduced in

bmi1a bmi1b plants, indicating that expression of RING1a and RING1b still expressed in this double mutant is not sufficient for activity of the PRC1 complex *in vivo* (Bratzel et al., 2010). These results suggest that both types of RING proteins must be present to constitute an active complex in cells, however, the exact subunit stoichiometry is not known (Bratzel et al., 2010).

The recent report of a PHD (PLANT HOMEODOMAIN) protein as an interactor of RING1a and BMI1b indicates that these RING proteins may be in other complexes as well (Molitor et al., 2014). Of note is that BMI1b and BMI1c were identified as DRIP1 (DREB2A-interacting protein), and DRIP2, respectively; proteins that interact with the transcription factor DREB2A [DEHYDRATION-RESPONSIVE ELEMENT BINDING PROTEIN, At5g05410 (Qin et al., 2008)]. Interestingly, similar to H2A.1, DREB2A is monoubiquitinated *in vitro* by DRIP1/BMI1a rather than polyubiquitinated, although whether this is true *in vivo* is not known. In analyzing the effects of *DRIP* mutants on stress responses, *drip1* (WiscDsLox437G06, same allele as *bmi1b*, above) and *drip2* (SALK_145041) single and double mutants were evaluated. Neither single mutant behaved differently than wild type, but the double was developmentally delayed and more resistant to drought (Qin et al., 2008).

Another RING protein found in distinct multi-protein complexes is COP1 (CONSTITUTIVE PHOTOMORPHOGENIC, At2g32950). COP1 regulates responses to red/far red, blue and UV-B light (Lau and Deng, 2012). Loss-of-function *cop1* alleles were first isolated from a genetic screen for dark-grown seedlings with light-grown characteristics, such as short hypocotyls and open reflexed cotyledons (Deng et al., 1992), indicating that COP1 acts as a negative regulator of photomorphogenesis. Multiple studies subsequently identified several transcription factors as substrates of COP1. These proteins are rapidly degraded in the dark from COP1-mediated ubiquitination. A notable substrate is HY5 (ELONGATED HYPOCOTYL 5, At5g11260) (Holm et al., 2002; Duek et al., 2004; Duek and Fankhauser, 2005; Yang et al., 2005). Red, far-red and blue wavelengths of light negatively regulate COP1 such that these transcription factors are stabilized upon light exposure and are then able to promote photomorphogenesis.

COP1 contains an N-terminal RING domain, a coiled coil region and a number of WD repeats (Holm and Deng, 1999). The COP1 coiled coil region interacts with itself and with SPA (SUPPRESSOR OF PHY A-105) proteins. There are 4 isoforms in *Arabidopsis*: SPA1-4 (At2g46340, At4g11110, At3g15354, At1g53090, respectively) and all interact with COP1 through their respective coiled coil domains (Laubinger et al., 2004). SPA proteins are not substrates of COP1. *In vitro* ubiquitination of the transcription factor LAF1 (LONG AFTER FAR-RED LIGHT 1, At4g25560) was enhanced by a SPA-COP1 complex compared to COP1 alone (Seo et al., 2003), but whether this is a general role for SPA proteins is not known. While these two proteins as the only E3 are capable of ubiquitinating substrates *in vitro*, *in vivo* the COP1-SPA complex associates with scaffold CULLIN4 (CUL4, At4g46210) to form a CRL-type ligase, containing the RING protein RBX1 (see above), and this CUL4-based CRL is thought to be the active ligase (Chen et al., 2006). Thus, the role of the COP1 RING domain in this dual-RING complex is not clear.

COP1 also functions in responses to UV-B irradiation (Oravec et al., 2006; Tilbrook et al., 2013), but here the story and the complex are different. In this signaling pathway, the functional unit does not appear to be a CUL4-based E3. Seedlings with suppressed

CUL4 expression did not show altered UV-B morphological nor transcriptional responses and the fraction of COP1 interacting with *CUL4* declined after UV-B exposure (Huang et al., 2013). COP1 interacts directly with the UV-B receptor UVR8 (UVB RESISTANT 8, At4g63860) in a UV-B-dependent manner (Favory et al., 2009). SPA proteins co-immunoprecipitate with UVR8 through association with COP1, indicating that the COP1-SPA linkage is maintained in UV light (Huang et al., 2013). Multiple loss-of-function *spa* mutants show defects in UV-B responses (Huang et al., 2013) consistent with their redundant role in UV signaling. Altogether, these results suggest that COP1-SPA dissociates from *CUL4* (by a yet unknown mechanism) and associates with UVR8 to form an E3 with a distinct specificity. UV-B responses are distinct from red/far red responses (Tilbrook et al., 2013). In UV-B light, HY5 degradation is slowed in wild type seedlings, but fails to accumulate in *cop1* mutants, indicating that COP1 is not merely inactivated in UV-B leading to HY5 accumulation as in red light, but plays an active role in stabilizing HY5 (Huang et al., 2013). The direct down-stream events in UV-B signaling remain to be elucidated. Thus, COP1 is present in distinct multi-protein complexes in response to different wavelengths of light. Identifying the molecular mechanisms controlling the formation and stability of the different COP1-containing complexes are of special interest.

While it was noted that *cop1* mutants flower early, the molecular events were resolved recently with the demonstration that CO (CONSTANS, At5g15840), a positive regulator of flowering, is a likely COP1 substrate. CO interacts directly with COP1 *in vitro* and *in vivo* and can be ubiquitinated by COP1 *in vitro* (Liu et al., 2008). SPA proteins are required for CO degradation, although the nature of this ligase is not completely understood (Laubinger et al., 2006; Jang et al., 2008; Liu et al., 2008).

COP1 shows an interesting dynamic light-dependent shift in localization; COP1 is nuclear-localized in the dark and cytosolic in the light (von Arnim and Deng, 1994; von Arnim et al., 1997). COP1 also interacts with phytochromes A and B and the blue light receptor CRY1 (CRYPTOCHROME, At4g08920) and CRY2 (At1g04400) (Lau and Deng, 2012). While components of these ligases have been identified, it is likely that additional interactors and other dynamic changes in complex composition remain to be characterized.

“Simple” RING proteins form homomers and/or heteromers

In contrast, other RING proteins were initially thought to function as single polypeptides; however recent evidence indicates that RING proteins interact with each other or related RINGs to form homomeric or heteromeric complexes, respectively, or interact with adaptor proteins that function to recognize substrates, modulate activity or to localize the ligase to a particular subcellular compartment or attach it to a membrane surface. How generally RING E3s operate as complexes remains an open question. A few examples have been described in *Arabidopsis*. Both RING proteins HUB1 and HUB2 are required for mono-ubiquitination of histone H2b (see above) and single *hub* mutants have the same aberrant phenotype, suggesting that HUB1 and HUB2 function together as a heteromeric ligase [recently reviewed in (Feng and Shen, 2014)]. The related RING proteins BRIZ1 (At2g42160) and BRIZ2 (At2g26000) interact *in vivo* and *in vitro* and single loss-of-

function mutants have the same germination defect, again suggesting that the two proteins function together in the same ligase (Hsia and Callis, 2010). RIN2 (RPM INTERACTING PROTEIN, At4g25230) and RIN3 (At5g51450) are closely related RING proteins that interact in Y2H assays (Kawasaki et al., 2005), but here the mutant phenotypes are additive. SINAT5 interacts with itself (Xie et al., 2002), suggesting it forms a multimeric complex. While these are only a few examples, they serve to remind us that the nature of the E3 ligase complex may be an important aspect to its function and begs further analyses.

Other RINGs are functional as single polypeptides

On the other hand, functional redundancy is suggested in the case of related RGLG1 and RGLG2, rather than single complex formation. Loss-of-function mutants in *RGLG1* and *RGLG2* individually have no phenotypic differences from wild type, while the double mutant is affected in auxin level and signaling, drought responses and iron deficiency responses (Yin et al., 2007; Li and Schmidt, 2010; Cheng et al., 2012). Similarly, the related RGLG3 (At5g63970) and RGLG4 (At1g79380) are functionally redundant in terms of regulating jasmonate-mediated wound responses (Zhang et al., 2012).

It is not possible to discuss all of the information on specific RING E3s that have been uncovered. The following sections summarize new information obtained on a few subgroups and RING proteins, highlighting the diverse and widespread influence of ubiquitination by this E3 type.

The XBAT RING E3s

The five XBAT (XB3 ortholog Two in *Arabidopsis thaliana*) RING proteins share N-terminal ankyrin repeats, a ~33 amino acid alpha helical rich protein-protein interaction region. XBAT32 (At5g57740) is implicated in regulating ethylene synthesis. It interacts in Y2H assays with a subset of ACC SYNTHASE (ACS) isozymes, ACS4 (At2g22810) and ACS7 (At4g26200) that catalyze the rate-limiting step in ethylene biosynthesis (Prasad et al., 2010). Both ACS4 and ACS7 were ubiquitinated by XBAT32 in *in vitro* assays using bacterially expressed substrates and E3 (Prasad et al., 2010) and epitope-tagged ACS7 was stable in the *xbat32* loss-of-function background (*xbat32-1*) (Lyzena et al., 2012). Similarly, using cell-free degradation assays, recombinant ACS4 was ~2-fold more stable in *xbat32-1* lysates compared to wild type lysates (Lyzena et al., 2012). These results suggest that XBAT32 recognizes a motif shared between these two proteins to modulate ethylene levels.

Physiological studies of the *xbat32* loss-of-function mutant support XBAT32's negative regulation of ethylene synthesis. *xbat32* seedlings produce ~2-fold more ethylene (Prasad et al., 2010), and have altered responses to exogenous ethylene and ABA and a reduction in lateral root number (Nodzon et al., 2004; Prasad et al., 2010; Prasad and Stone, 2010). Curiously, two related E3s, *xbat34* (At4g14365) and *xbat35* (At3g23280) have wild-type lateral root number and a wild type ABA-mediated re-

duction in lateral roots (Prasad et al., 2010), indicating these related proteins have distinct functions from XBAT32. Dark-grown *xbat35* seedlings exhibited an exaggerated hook compared to wild type in the presence of the ethylene precursor ACC, implicating this XBAT specifically in regulating ethylene-mediated apical hook curvature response (Carvalho et al., 2012).

The ATL and BTL RING E3s.

The 91 ATL (genes de Arabidopsis Tóxicos en Levadura- Arabidopsis genes toxic to yeast) RING proteins (Aguilar-Hernández et al., 2011) are members of a plant-specific subfamily characterized by one or more N-terminal putative transmembrane domains and a ~12 amino acid GLD motif followed by a 42 amino acid RING-H2 type domain. Among the ATLs, the number of amino acids between ml residues in the RING domain is strictly conserved and specific amino acids adjacent to ml residues are also conserved. The GLD motif consists of 12-16 conserved amino acids starting with a conserved glutamate-leucine-aspartate sequence and is of unknown function (Salinas-Mondragón et al., 1999; Serrano and Guzmán, 2004; Serrano et al., 2006; Aguilar-Hernández et al., 2011). Only six ATL proteins lack the N-terminal hydrophobic region, with the vast majority (93%) containing 1-3 predicted transmembrane domains (Aguilar-Hernández et al., 2011). Based on identity outside these 3 conserved regions, ATL proteins have been divided into 9 subgroups (A-I), with Arabidopsis lacking only the monocot-specific subgroup (Aguilar-Hernández et al., 2011). There have been several excellent and comprehensive reviews of this subfamily (Serrano et al., 2006; Aguilar-Hernández et al., 2011; Guzmán, 2012).

Although only a small subset of ATLs have been analyzed, ATL members were found localized to different membranes; ATL9 (At2g35000) localizes to the ER, while ATL55/RING1 (At5g10380) and ATL78 (At1g49230) localize to the PM (Lin et al., 2008; Berrocal-Lobo et al., 2010; Kim and Kim, 2013). Either one or both NIP (NEP INTERACTING PROTEIN) proteins (At2g17750, ATL26/NIP1 and At2g17730, ATL25/NIP2) localize to chloroplast thylakoids and appear to be essential for membrane localization of PpoTnp, a phage type plastid RNA polymerase important during early chloroplast development (Azevedo et al., 2008). Whether the NIP proteins function as E3s has not been established. An interesting and novel role for the RING domains of NIP1 and NIP2 in chloroplasts could be as protein-protein interaction platforms, rather than as E3 ligases. For the ATLs in general, while it is likely that their putative transmembrane domain targets these proteins to a specific membrane, it is not clear how this specificity is achieved.

Several ATL proteins are implicated in biotic and abiotic stress responses. For example, *ATL2* and *ATL9* mRNAs accumulate in response to chitin (Serrano and Guzmán, 2004; Berrocal-Lobo et al., 2010) and 8 other *ATLs* are part of a chitin response pathway because their expression is altered similarly to *ATL2* in one or more *eca* (*expresión constitutiva de ATL2, constitutive ATL2 expression*) mutant backgrounds (Serrano and Guzmán, 2004). In an independent study, other *ATL* mRNAs are induced >10-fold 30 minutes after chitin exposure (Libault et al., 2007). *ATL55/RING1* mRNA is induced after exposure to *Pseudomonas syrin-*

gae DC3000 avr RPM1, the fungal toxin fumonisin B1 and chitin (Libault et al., 2007; Lin et al., 2008). *ATL78* mRNA is increased by cold and a loss-of-function mutant is cold hypersensitive, but drought hyposensitive (Kim and Kim, 2013).

In addition to a transcriptional response to chitin (Libault et al., 2007), *ATL31* [At5g27420, also named CNI1 for CARBON/NITROGEN INSENSITIVE (Sato, 2011)] and *ATL6* (At3g05200) operate in response to carbon to nitrogen status. They bind to 14-3-3 χ in Y2H and *in vitro* pull-down assays (Sato, 2011). Furthermore, both ubiquitinate 14-3-3 χ *in vitro* and negatively regulate its abundance *in vivo*. Remaining unknown is the function of this interaction in C/N sensing. Another *ATL62* (At3g19140) has a diverged function; it plays a role in regulating flowering time (Morris et al., 2010).

Related RING-H2 proteins are 17 BTL (Breast Cancer Associated 2 zinc finger [BZF] ATL) proteins (Aguilar-Hernández et al., 2013). These proteins have a similar RING-H2 domain and the GLD motif found in ATLs, but lack the hydrophobic N-terminus, having instead a BZF motif, a C2 zinc finger (Guzmán, 2012). Several BTL proteins have been described previously; they are CIP8 (CONSTITUTIVE PHOTOMORPHOGENIC [COP] INTERACTING PROTEIN 8, At5g64920, BTL12, (Hardtke et al., 2002)), RDUF1 (RING DOMAIN OF UNKNOWN FUNCTION 1117, At3g46620, BTL10, (Kim et al., 2012)), RDUF2 (At5g59550, BTL9, (Kim et al., 2012)) and RZF1 (RING ZINC FINGER 1, At3g56580) (Ju et al., 2013). While the ATLs appear to be plant-specific, relatives of the BTLs are found in animals and fungi (Aguilar-Hernández et al., 2013). The BZF region of one BTL, *BTL4* (At5g56340), interacts with ubiquitin in a Y2H assay, while the region in between the BZF and the RING-H2 motif interacts with a number of potential substrates (Aguilar-Hernández et al., 2013). CIP8 interacts with COP1, and ubiquitinates HY5 linking it to light signaling (Hardtke et al., 2002). In contrast, RDUF1 and RDUF2 function in drought response pathways (Kim et al., 2012) and *RZF1* mRNA is drought inducible (Ju et al., 2013). Thus, ATLs and BTLs have diverse biological functions.

RING E3s and the N-end rule

A ubiquitin-dependent proteolytic pathway recognizing the N-terminal residue of proteins was initially characterized in yeast and mammalian cells [for recent general reviews see (Varshavsky, 2011; Tasaki et al., 2012)]. Termed the N-end rule, studies demonstrated that the nature of the N-terminal residue of a protein determines its *in vivo* stability (Figure 5). Specific residues called primary (1°) destabilizing residues, such as the basic amino acids Arg and Lys, are de-stabilizing directly by virtue of recognition by a specific E3 or E3s. Other amino acids at the N-terminus require modification prior to interaction with an E3; for example, Gln and Asn are considered tertiary de-stabilizing (3°) residues because they must be first deaminated to Glu and Asp, respectively, and then Glu and Asp (secondary destabilizing, 2°) are substrates of an arginyl-tRNA:protein arginyltransferase (R-transferase) activity, finally resulting in a 1° destabilizing residue, Arg, at the N-terminus. Remarkably, there are few differences in the N-end rule between plants and mammals [reviewed in (Graciet and Wellmer, 2010)].

To identify proteins functioning in the N-end rule pathway in Arabidopsis, a genetic screen was performed using transgenic plants

expressing an unstable artificial protein, F-DHFR (mammalian dihydrofolate reductase with phenylalanine at the N-terminus- see section on ubiquitin genes for how this is generated) (Bachmair et al., 1986; Potuschak et al., 1998; Stary et al., 2003). Plants normally degrade F-DHFR rapidly and are sensitive to the DHFR

inhibitor methotrexate (MTX). However, plants with reduced degradation of F-DHFR accumulate sufficient DHFR to be MTX resistant. From this screen, a mutant allele of *PRT1* (PROTEOLYSIS 1, At3g24800), encoding a RING-type E3 was isolated (Potuschak et al., 1998). Further analysis indicated that PRT1 recognizes aromatic N-termini, Phe, Trp and Tyr (Stary et al., 2003).

Additional studies measuring degradation of other artificial fusions defined stabilizing and destabilizing residues in plants (Worley et al., 1998; Schlogelhofer and Bachmair, 2002; Graciet et al., 2010) and identified other components of the N end rule pathway; additional E3s such as PRT6 (At5g02310) which binds N-terminal Arg (Garzon et al., 2007) and processing enzymes- R-transferases [ATE1, At5g05700 and ATE2, At3g11240; (Yoshida et al., 2002)].

In mammals, an arginine is transferred to the N-terminus of several types of proteins with N-terminally oxidized cysteine residues as well as those with N-terminal amino acids Asp or Glu (Graciet and Wellmer, 2010; Tasaki et al., 2012). A similar pathway involving Cys at the N terminus in plant proteins has been recently revealed. For ERF (Ethylene Response Factor) subfamily VII-type transcription factors, such as RAP2.12 (Protein RELATED TO APETALA2, At1g53910), the N-terminal residue is a cysteine residue due to removal of the initiator methionine. Under non-moxic conditions this cysteine is oxidized, then modified with an N-terminal arginine, which targets this nuclear-localized protein for recognition and ubiquitination by PRT6. In contrast, under low oxygen conditions, these modifications fail to occur and RAP2.12 is stable, resulting in an increase in RAP2.12-dependent transcription (Gibbs et al., 2011; Licausi et al., 2011; Weits et al., 2014). All five Arabidopsis ERFVII-type transcription factors are similarly regulated (Gibbs et al., 2011). Thus, nuclear localization and oxygen regulated proteolysis controls the activity of key transcription factors in hypoxic survival response (Bailey-Serres et al., 2012; Licausi et al., 2013).

Recently, studies linked nitric oxide sensing to regulating ERF-type transcription factor abundance through cysteine oxidation, arginylation and PRT6 as described above for hypoxia. These studies significantly expand the scope of influence of PRT6 to a myriad of processes; oxygen sensing, NO signaling, seed germination, seedling growth and other ABA-regulated responses (Gibbs et al., 2014).

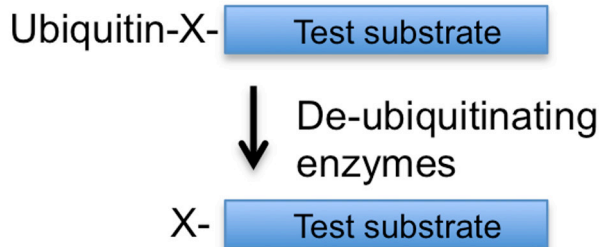

Stabilizing N termini X=
M, G, S, A, T, V

Destabilizing N-termini X=
Type of destabilizing residue

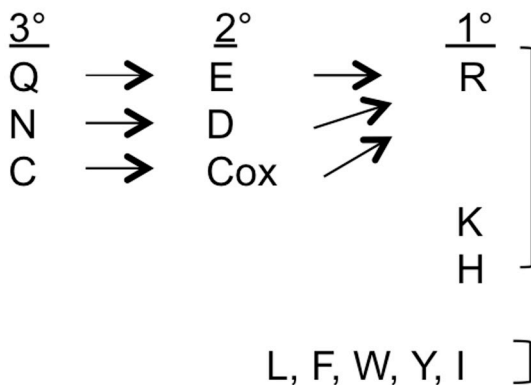

Figure 5. Diagram of the Arabidopsis N-end rule pathway.

Top, Proteins co-synthesized with N-terminal ubiquitin coding region (ubiquitin fusion) are cleaved by de-ubiquitinating enzymes to generate a test protein with a specified encoded N-terminal residue (X). The stability of the test protein is determined by the nature of this N-terminal residue (X). Some amino acids are recognized directly by E3s and are considered 1° destabilizing residues. Others require conversion to 1° destabilizing residues. For the 3° de-stabilizing amino acids, glutamine (Q) and asparagine (N), the R amide groups are hydrolyzed by deamidases to generate the 2° de-stabilizing amino acids, glutamate (E) and aspartate (D). An arginine residue is transferred to the N-termini of E and D, converting them to a 1° destabilizing residue. Other basic residues, lysine (K) and histidine (H), are recognized by the same type of E3. Hydrophobic residues, such as leucine (L), phenylalanine (F), tyrosine (Y), tryptophan (W) and isoleucine (I) are also 1° destabilizing, but are recognized by different E3s. Cysteine (C) is considered a 3° destabilizing residue because it requires oxidation before arginylation.

RING Proteins in Chloroplast Protein Control

Proteolytic regulation of import into the chloroplast has emerged as a role for the ubiquitin pathway. The RING protein SP1 [SUPPRESSOR OF PLASTID PROTEIN IMPORT LOCUS, At1g63900, also named DIAP1-like protein, DAL1 (Vindhya et al., 2011)] regulates the abundance of the TOC1 (Translocation at the outer envelope of chloroplasts) complex, the outer membrane translocation machinery (Ling et al., 2012). While SP1 is anchored to the outer envelope via two TM regions, its C-terminal RING domain faces the cytosol, presumably to have access to E1, E2 and ubiquitin. SP1 interacts with and ubiquitinates multiple TOC proteins *in vitro* (Ling et al., 2012). This turnover of TOC is proposed to facilitate developmental transitions, when different TOC complexes are utilized such as during greening and senescence (Ling et al., 2012; Jarvis and Lopez-Juez, 2013).

U box E3s

The U-box is a ~70 amino acid motif that serves as the E2 docking site. The 3D-NMR structure for an Arabidopsis U-box protein, PLANT U-BOX 14 (PUB14, At3g54850), reveals a protein fold strongly resembling a RING domain, but the RING cysteine and histidine residues that chelate Zn²⁺ are replaced by a network of hydrogen bonds using cysteine, serine and glutamate side chains. The tertiary structure is also stabilized by hydrophobic interactions and salt bridges (Andersen et al., 2004). PUB14 is active in ubiquitination assays *in vitro* with human Ubc5b (now called Ube2D3), a generic E2, but not with UbcH13 (Ube2N) (Andersen et al., 2004).

Currently, 64 U-box proteins are identified in Arabidopsis using the U-box motif from yeast and animals in sequence similarity searches (Azevedo et al., 2001; Mudgil et al., 2004; Wiborg et al., 2008; Yee and Goring, 2009), far more than the one in yeast and six in humans (Cyr et al., 2002). Arabidopsis U-boxes have been given the systematic designation PLANT U-BOX (PUB) followed by a number, with the single exception of CARBOXYL TERMINUS OF HSC70-INTERACTING PROTEIN (CHIP, At3g07370). There are only a few additions/changes to the PUB protein/gene list since the initial description of the family [(http://www.arabidopsis.org/browse/genefamily/pub.jsp) see updating in Table 7]. One putative U-box protein previously reported as PUB62 [At3g49065, (Wiborg et al., 2008)], is not present in the TAIR10 annotation and the previous PUB63 [At5g05230; (Wiborg et al., 2008)] is now PUB62 in UniProt [http://www.uniprot.org]. A new PUB63 is annotated in UniProt (At2g40640). A subset of the PUBs is listed in Table 7. Most PUBs contain one or more additional identifiable domains; the initial five domain organization types (Azevedo et al., 2001) has expanded to thirteen (Yee and Goring, 2009). Forty-one of the 63 U-boxes contain a variable number of armadillo repeats (ARM), while another fifteen PUBs contain a kinase domain. PUB49 (At1g66160) has both *in vitro* ubiquitination activity and peptidyl-prolyl cis-trans isomerase activity (Yee and Goring, 2009).

To establish which E2s partner with the U-box motif and to further explore E2-E3 specificity, seven different U-box proteins, sampling the domain diversity described above, were tested with six different Arabidopsis E2 proteins by *in vitro* ubiquitination assays (Wiborg et al., 2008). These seven U-box proteins (Table 7) were active with two E2s from the generic class, UBC10 and UBC29, and three (PUB49, 55, 56) were additionally active with two related UBCs, UBC35 and 36. PUB49, 55, 56 are not closely related, suggesting that a small number of residues confer E2 interaction specificity that is not apparent from overall sequence identity. When Ala was substituted for a conserved Trp in the PUB54 U-box, no activity was detected with 4 E2s, however, when the same site was substituted with His, a residue found in some U-boxes, E3 activity was not eliminated, but selectivity was altered. Activity was more reduced with UBC35 and UBC36 than with the two generic E2s. These data support a scenario that a small number of interactions are responsible for E2-E3 specificity, suggesting that it may be challenging to predict which E2 will productively interact with any E3.

The biological functions of several U-box proteins were summarized in Yee and Goring (2009). Subsequently, roles for additional U-boxes have been described, confirming their partici-

pation in defense and abiotic stress responses, and revealing a few surprises (Table 7). PUB13 (At3g46510) co-immunoprecipitates with BRI1-ASSOCIATED RECEPTOR KINASE1 (BAK1, At4g33430) and the flagellin receptor, FLAGELLIN SENSING2 (FLS2, At5g46330) from plant extracts. Interestingly, the latter interaction depends on pre-treatment of seedlings with the peptide elicitor flg22 and the presence of kinase active BAK1, suggesting that phosphorylation of PUB13 promotes its interaction with FLS2 (Lu et al., 2011). Both PUB12 (At2g23140) and PUB13 catalyze ubiquitination of FLS2 *in vitro*, and FLS2 reduction after flg22 treatment is lost in *pub12 pub13* loss-of-function plants. PUB12 and 13 are likely partially redundant in the same process; *pub12 pub3* plants were more resistant to *Pseudomonas syringae pv tomato* DC300 (*Pst*) infection than wild type or the single mutants. Thus, PUB12/13 function to down-regulate the FLS2 immune receptor after stimulation. Analogous ubiquitin-dependent processes utilizing different E3s have been observed for other innate immune receptors in plants (Cheng and Li, 2012; Furlan et al., 2012), and also for mammalian Toll-like receptors (Chuang and Ulevitch, 2004), indicating a highly conserved mechanism to regulate innate immunity receptor levels.

Another study suggests that PUB13 has a unique role as well (Li et al., 2012). *pub13* flowers early and *pub13* leaves show early senescence and increased trypan blue staining (which stains only dead cells) even prior to visible chlorosis, indicative of cell death. These phenotypes are lost when salicylic acid (SA) levels are reduced, and measurement of SA indicates slight elevation of SA in *pub13* plants. These studies link PUB13 to regulation of SA levels, which in turn has pleiotropic downstream effects- both developmental and in defense responses.

mRNAs for several PUBs increase in response to abscisic acid (ABA), with *PUB19* (At1g60190) showing a remarkable ~160-fold increase after 3-5 hours in 50 μM ABA (Hoth et al., 2002). The most closely related *PUB* to *PUB19*, *PUB18* (At1g10560), shows ~11-fold induction (Hoth et al., 2002). Double homozygous *pub18 pub19* seedlings show a slight resistance to ABA and salt during germination that is not evident in the single mutants (Bergler and Hoth, 2011). In contrast, another study found *pub19* mutants alone hypersensitive to ABA, with *PUB19* over-expressors being ABA hyposensitive (Liu et al., 2011). Similarly, study of *pub18* loss-of-function mutants and over-expressing lines indicate the same trends, ABA-hypersensitivity and hyposensitivity, respectively (Seo et al., 2012). These effects were not seen with similar alterations in *PUB22* and *PUB23*, indicating some specificity, however *pub22 pub23* double mutant plants were more drought resistant, but possibly through a different mechanism (Seo et al., 2012).

PUB17 (At1g29340) appears to be the functional homolog of tomato ACRE276 based on transient disease assays using tobacco (Yang et al., 2006). While wild-type tobacco leaves exhibit a hypersensitive response after infiltration with Avr9 peptide, ACRE276-silenced stable tobacco leaves do not. Transient expression of *PUB17* in ACRE276-silenced leaves restores the hypersensitive response to Avr9 peptide (Yang et al., 2006). *pub17* plants look wild type under normal growth conditions, but have reduced resistance against avirulent *Pseudomonas syringae pv tomato* (*Pst*), indicating *PUB17*'s role in defense responses (Yang et al., 2006).

PUB44 (At1g20780, also called SAUL1, for SENESCENCE ASSOCIATED UBIQUITIN LIGASE1) loss-of-function mutants exhibit early leaf senescence that is dependent on photon flux

Table 7. U box E3s

Name	AGI	in vitro Activity	Localization	Domains	Comments	Proposed Physiological Process	References
CHIP	At3g07370	active with UBCH5a		TPR	heat and cold increases mRNA	chloroplast target precursor proteins, abiotic stress	Yan et al 2003; Lee, et al 2009
PUB04	At2g23140	in vitro self-ubiquitination after expression in Arabidopsis and affinity purification	cytosolic	ARM	pub4 have defects in tapetal layer, affecting pollen release; slight vegetative phenotype	development	Wang et al 2013
PUB09	At3g07360			ARM + UND	transcriptionally induced by ABA	stress	Hoth et al 2002
PUB12	At2g23140	active with UBC8			together with PUB13 mediate FLS2 down-regulation	disease resistance	Lu et al, 2011
PUB13	At3g46510	active with UBC8; active with HUCB5b		UND + ARM	together with PUB12 mediate FLS2 down-regulation	biotic stress	Lu et al 2011; Li et al 2012
PUB14	At3g54850	active with human Hubc5b, not with human Ubch13; active with AtUBC10 and UBC29, not active with UBC34, 35 and 36, slightly active with UBC13	cytosolic	ARM + UND	NMR structure of U-box domain		Andersen et al 2004; Wiborg et al 2008
PUB17	At1g29340	active with human Hubc5b			functional homolog of tomato ACRE276	stress; disease resistance	all data in Yang et al 2006
PUB18	At1g10560			ARM + UND	transcriptionally induced by ABA; pub18/18 slight resistance to ABA in germination	stress	Hoth et al 2002;
PUB19	At1g60190	active with UBCH5b		ARM + UND	transcriptionally induced by ABA	stress	Hoth et al 2002; Liu et al 2011
PUB20	At1g66160	active with UBCH5b	nuclear + cytosolic	ARM	interacts with Arabidopsis G protein BETA (AGB1), but no ubiquitination of AGB1 observed in vitro; no phenotype for pub20, promoter-GUS shows wound induction	stress	Kobayashi et al 2012; Heise, et al 2002
PUB22	AT3g52450	active with UBCH5b			redundant with PUB23 and PUB24; mRNA induced after flg22 treatment; negative regulator of transient PAMP-dependent resistance response	disease resistance	Trujillo et al 2008

(Continued)

Table 7. (continued)

Name	AGI	in vitro Activity	Localization	Domains	Comments	Proposed Physiological Process	References
PUB23	AT2g35930	active with UBCH5b			redundant with PUB22 and PUB244; mRNA induced after flg22 treatment; negative regulator of transient PAMP-dependent resistance response	disease resistance	Trujillo et al 2008
PUB24	AT3g11840	active with UBCH5b			redundant with PUB22 and PUB234; mRNA induced after flg22 treatment; negative regulator of transient PAMP-dependent resistance response	disease resistance	Trujillo et al 2008
PUB41	At5g62560	active with AtUBC10, 29 NOT active with UBC13,34,35, 36					Wiborg et al 2008
PUB44/ SAUL1	At1g20780	active with human Hubc5b	PM (also PUB42 and 43)	ARM	mRNA induced or not by ABA; see text for additional data	cell death; abiotic stress	Hoth et al 2002; Raab et al 2009; Salt et al 2011
PUB49	At1g66160	active with AtUBC10, 29 and UBC35, 36			contains peptidyl-prolyl cis-trans isomerase activity		Wiborg et al 2008
PUB54	At1g01680	active with AtUBC10, 29 and UBC35, 36, slight activity with UBC13 and 34					Wiborg et al 2008
PUB56	At1g01670	active with AtUBC10, 29 and UBC35, 36, slight activity with UBC13 and 34					Wiborg et al 2008
PUB59/ MAC3A/ PRB19A	AT1g04510		nuclear		Pre-mRNA-processing factor 19 homolog A; MOS4-associated complex protein 3A	disease resistance	Monaghan et al 2009
PUB60/ MAC3B/ PRB19B	At2g33340	active with AtUBC10, 29 NOT with UBC13, 34,35, 36	nuclear		Pre-mRNA-processing factor 19 homolog B; MOS4-associated complex protein 3B	disease resistance	Wiborg et al 2008; Monaghan et al 2009
PUB61	At5g57035	active with AtUBC10, 29, 13, 34, but NOT with UBC35, 36					Wiborg et al 2008
PUB62 (old)	At3g49065				OBSELETE, not present in TAIR10		named in Wiborg et al 2008
PUB62	At5g05230				not named in Wiborg et al 2008		
PUB63 (new)	At2g40640				UniProt name is PUB63, not named in Wiborg et al 2008		

UND= U-box N terminal domain

ARM= armadillo repeats

density (PFD) (Raab et al., 2009; Salt et al., 2011). Senescence is suppressed at higher PFD. ABA-induced leaf senescence is intact in *saul/pub44* mutants. However, at low PFD, ABA content is 10-fold higher than wild type and higher than *saul1/pub44* plants at high PFD (Raab et al., 2009). The abundance of one isozyme of aldehyde oxidase (AAO3) in the ABA biosynthetic pathway was higher in *saul1/pub44* plants at low PFD, suggesting that increased ABA synthesis and then subsequently high ABA levels promotes premature senescence under this growth condition (Raab et al., 2009).

SAUL1/PUB44 was initially proposed to affect only leaf senescence, however, the observed increased cell death in other organs in null plants suggests that it may have a broader role (Salt et al., 2011). In support of this broader role, germination of *saul1/pub44* seeds are more resistant to salt, mannitol and glucose than wild type, but no changes in resistance to virulent *Pst* were observed in treated four-week-old plants (Salt et al., 2011). In contrast, *saul1/pub44* seedlings after growth at higher PFD were more sensitive to salt (Vogelmann et al., 2012), indicating developmental-specific effects. The premature leaf senescence phenotype is suppressed in *pad4* (*PHYTOALEXIN RESISTANT4*), although not suppressed in a SA-receptor deficient background, implicating a PAD4-dependent aspect of the process that is not fully understood (Vogelmann et al., 2012). Given the complex interplay between ABA and SA, future experiments will be needed to sort out primary and secondary responses mediated by SAUL1/PUB44.

SAUL1/PUB44 intracellular localization is not quite resolved. In one study, GFP-SAUL1 localized to the plasma membrane (PM) of Arabidopsis protoplasts and tobacco leaves after transient transfection (Drechsel et al., 2011). This localization was dependent on C-terminal ARM repeats (Drechsel et al., 2011). In another study localization was assessed in tobacco BY-2 cultured cells (Salt et al., 2011). Here, SAUL1-GFP intracellular localization was dynamic. SAUL1-GFP exhibited distribution of perinuclear and PM localization that shifted to mostly PM localization after treatment of the cells with ABA or methyl jasmonate (Salt et al., 2011). Co-expression of SAUL1-GFP with two different kinases known to phosphorylate ARM-containing proteins also shifts intracellular localization to the PM (Salt et al., 2011).

A survey of PUB localization in protoplasts identified PUB42 and PUB43, relatives of SAUL1/PUB44, as PM-localized (Drechsel et al., 2011). PUB48 was solely nuclear, a few were solely cytosolic (e.g. PUB14), while still others displayed both nuclear and cytosolic localization (Drechsel et al., 2011). Curiously, while most fluorescence is diffuse, several GFP-PUB fusions exhibit punctate patterns, either at the PM (PUB17) or internally (PUB20, PUB41). Information on intracellular localization, and whether dynamic or static, will inform future models as to biological function. While clearly PUB proteins play significant roles in biotic and abiotic defense responses, probing for substrates and verifying direct downstream *in vivo* effects remain as future challenges.

Work on PUB4 (At2g23140) suggests roles beyond defense responses for this PUB. *pub4* loss-of-function plants have minor vegetative differences from wild type, with smaller rosettes, narrower leaves and shorter inflorescences (Wang et al., 2013). The greatest difference from wild type is seen in anthers; *pub4* anthers with altered tapetum fail to dehisce and while *pub4* pollen are viable, they have an altered exine (Wang et al., 2013).

CARBOXY TERMINUS OF HSC70-INTERACTING PROTEIN (CHIP, At3g07370) represents a rather unique U-box protein with a specialized function in plants. CHIP co-immunoprecipitates with Hsc70 after expression in protoplasts, as do the recombinant proteins (Lee et al., 2009). Hsc70 interacts with transit peptides of proteins destined to the plastid. Expression of a truncated version of CHIP, without the U-box, but with its conserved tetratricopeptide repeat (TPR) domain, reduced degradation of cytosolic transit peptide-containing model proteins, implicating CHIP as the E3 responsible for preventing accumulation of precursor proteins in the cytosol. CHIP exhibits E3 activity *in vitro* (Yan et al., 2003). CHIP mRNA increased in response to a daily 2-hour heat stress (34°C) for 3-4 weeks or to 12°C treatment for 5-6 weeks (Yan et al., 2003). These treatments had a dramatic effect on growth of CHIP over-expressing plants, severely inhibiting growth compared to wild type. Continued analysis of CHIP-OE plants showed increased cell death and production of hydrogen peroxide (Shen et al., 2007a). A molecular understanding of the phenotypes of CHIP over-expressing plants came from identification of interacting proteins. Surprisingly, CHIP interacts with CHLOROPLAST PROTEINASE4 (ClpP4, At5g45390) and FILAMENTATION TEMPERATURE SENSITIVE H1 (FtsH1, AT1G50250), both chloroplast-localized proteases, synthesized in the cytosol and imported (Shen et al., 2007a; Shen et al., 2007b). Consistent with its role in regulating precursor protein accumulation, CHIP OE plants could have a hyperactive surveillance mechanism with over-zealous ubiquitination of unprocessed precursors, which results in reduced precursor available for import and in turn, reduced chloroplast levels of these proteases.

The role of CHIP may be broader as it interacts with two isoforms of the A subunit of PROTEIN PHOSPHATASE 2A (PP2AA3, At1g13320 and RCN1, At1g25490) (Luo et al., 2006). *In vitro*, CHIP mono-ubiquitinates these same proteins. Over-expression of CHIP does not affect their accumulation *in vivo* but may affect PP2A activity in response to cold or prolonged dark treatment (Luo et al., 2006). Consistent with a possible altered stress response, ABA sensitivity is affected in CHIP OE plants (Luo et al., 2006). It is curious that CHIP has such diverse functions; targeting chloroplast destined proteins for proteolysis and modifying PP2A activity. Hopefully future efforts will link these two together, alternatively, perhaps distinct interactors lead CHIP to distinct biological processes.

HECT type E3s

The HECT (Homology to E6-AP Carboxy Terminus) E3s are named after the ~350 amino acid conserved domain present in the first protein of this group to be analyzed, human E6-AP (E6-Associated Protein). There are seven HECT proteins in Arabidopsis (Table 8) divided into four (Downes et al., 2003) or five (Marín, 2013) subfamilies based on amino acid identity, presence of other domains and conservation in the Viridiplantae. HECT proteins are termed UBIQUITIN PROTEIN LIGASES (UPLs) in Arabidopsis. UPL1 (At1g55860) and UPL2 (At1g70320) are 85% similar and very large proteins at ~3700 amino acids. Using *in vitro* substrate independent ubiquitination assays, the HECT domain of UPL1 was active only with a generic E2, UBC8; UBC1, UBC4 and UBC7

as representatives of other E2 subfamilies (see above) were not active in parallel assays (Bates and Vierstra, 1999).

A UPL with an *in vivo* characterized role is UPL3 (At4g38600), also known as KAKTUS (KAK). First identified from an EMS mutant screen for altered trichome morphology, all loss-of-function *kak* mutants have extra trichome branching and enlarged nuclei with increased DNA content (Hulskamp et al., 1994; Perazza et al., 1999; Downes et al., 2003; El Refy et al., 2003). Originally the effect was thought to be limited to trichomes, however, DNA content in the hypocotyl and cotyledons is increased in *kak* light-grown seedlings (El Refy et al., 2003), indicating that KAKTUS represses endoreduplication in multiple cell types and developmental contexts. KAK/UPL3 has been linked to regulating the stability of two basic-helix-loop-helix (bHLH) transcription factors, GLABROUS 3 (GL3, At5g41315) and ENCHANCER OF GLABROUS 3 (EGL3, At1g63650) that function as positive regulators of trichome development (Patra et al., 2013). Degradation of GL3 and EGL3 are slowed in *upl3* extracts and in *upl3* seedlings compared to wild type controls (Patra et al., 2013). The N-terminal region of UPL3 containing armadillo repeats interacts with the C-termini of GL3 and EGL3 in Y2H assays, suggesting that GL3 and EGL3 are direct substrates of UPL3 ubiquitination activity (Patra et al., 2013).

In a Y2H screen, UPL5 (At4g12570) interacted with WRKY53 (At4g23810), a transcription factor acting positively in leaf senescence (Miao and Zentgraf, 2010). Over-expression of WRKY53 results in early leaf senescence, a phenotype also observed in *upl5* loss-of-function mutants and over-expression of UPL5 correlated with reduced expression of WRKY53. WRKY53 was ubiquitinated by UPL5 in *in vitro* assays and they interacted *in planta*. Altogether, these data strongly support a model whereby UPL5 negative regulates WRKY53 abundance through ubiquitination. While only a few other WRKY proteins were tested, neither WRKY4, WRKY15 nor WRKY33 interacted *in planta* with UPL5 (Miao and Zentgraf, 2010).

RBR E3s

Recently, a unique mechanism of ubiquitin transfer was discovered in a subgroup of RING proteins, and the differences are considered significant enough to separate them into a unique clade. These are the RBR proteins, which are unusual in containing 3 Cys/His-rich regions; an N-terminal one closely resembling a consensus RING domain, followed by a Cys/His region (IBR, for In-between RING) and a second, less conserved RING-like domain, hence the original name RBR for RING-in Between-RING. The latter RING-like domain is structurally variable among RBR proteins, binding either one or two zinc atoms, and in having an unliganded cysteine residue required for activity. Spratt et al (Spratt et al., 2014) recommend that the RBR abbreviated name instead refer to the 3 conserved regions as RING Benign-catalytic Required-for catalysis to more accurately reflect their respective functions and the unique catalytic activity of these proteins.

RBR E3s combine properties of both RING and HECT E3s. Non-covalent interaction with E2~Ub occurs at the first RING domain as in RING/U box proteins, but then the “activated” ubiquitin is transferred to a conserved Cys residue in the second

RING-like domain as in the HECT type E3s. “Activated” ubiquitin is finally transferred to the substrate from this thiol intermediate, again resembling HECT type E3 mechanism. In other words, in contrast to all other RING and U box E3s, the E2~Ub bound to RING1 in RBRs is attacked not by an ϵ -NH₂ group (such as on a substrate) but by a cysteinyl thiol in the same E3 protein in a transthioleation reaction as in HECT E3s. Intriguingly, requirements in the E2 for ubiquitin transfer to an NH₂ group are not same as for the transthioleation reaction to the E3 thiol. An asparagine ~8-9 residues N-terminal to the catalytic cysteine in E2s is required for transfer from the E2 to an NH₂ group, but is completely dispensable for transfer to a cysteinyl group in a HECT or RBR E3 (Wu et al., 2003; Wenzel et al., 2011a). While the catalytic cysteine can be identified, the required residues in E2 and RBRs for the transthioleation reaction remain to be elucidated (Spratt et al., 2014).

There are 42 RBR proteins in Arabidopsis, divided into 4 subgroups (Marín, 2010). One prominent subgroup with 14 expressed and 2 pseudogenes (Mladek et al., 2003) is the Adriadne (ARI) E3s. In addition to the RBR region, these proteins share the Adriadne motif, a ~150 amino acid conserved region of unknown function C-terminal to the IBR domain. This region was originally described in a *Drosophila* protein, named Ariadne, required for neuronal development (Marín and Ferrús, 2002). In a human Ariadne-like E3, the Ariadne domain interacts with the RING2 region and blocks access to the catalytic cysteine, and the full length enzyme is inactive in *in vitro* ubiquitination assays (Duda et al., 2013). Several other human RBR proteins have other auto-inhibitory domains, suggesting that auto-inhibition may be group trait (Smit and Sixma, 2014; Spratt et al., 2014). While there are no data for the Arabidopsis RBR proteins, auto-inhibition should be considered to determine whether it is a conserved trait in RBR proteins. *In vitro* activity can be detected for a GST fusion of At1g63450/ARI8 with the generic E2 UBC8 (Kraft et al., 2005), suggesting that if the Ariadne domain is inhibitory in this protein, the inhibition is either incomplete or undetectable *in vitro* with this E2.

Little is known regarding the biological functions for Adriadne subgroup of RBR proteins. Interestingly, *ARI12* (At1g05880) mRNA is induced by UV-B irradiation (Lang-Mladek et al., 2012). *ARI14* (At5g63730) is implicated in fertilization because inappropriate expression in pollen leads to reduced seed set, despite apparently normal pollen development, germination and pollen tube guidance (Ron et al., 2010). *ARI14* appears to be under control of an anti-sense siRNA; when *ARI14* is over-expressed, fertilization is reduced. Because *ARI14* is missing several Zn-chelating residues in RING1, it may be inactive. Perhaps *ARI14* has an inhibitory function that works in trans on other Ariadne proteins expressed in pollen rather than in cis as described above (Ron et al., 2010).

PERSPECTIVES ON E2-E3 INTERACTIONS AND SPECIFICITY

Can the ubiquitination outcome of an E2-E3 interaction be predicted? Knowing the involvement of a specific E2 and E3 in a process, can we predict if the outcome will be monoubiquitination or polyubiquitination of a substrate? And if polyubiquitination occurs, will the product be a K48 chain, K63 chain (or other), or a

Table 8. HECT type E3s

Gene	AGI Number	Other Names	Comments	References
UPL1	At1g55860			
UPL2	At1g70320			
UPL3	At4g38600	KAKTUS		El Refy et al 2003; Downes et al 2003
UPL4	At5g02880	KLI5	(KAKTUS LIKE chromosome 5)	El Refy et al 2003
UPL5	At4g12570			
UPL6	At3g17205			
UPL7	At3g53090			

mixed chain added to a substrate lysine, serine/threonine or cysteine? To date, we have insufficient information to answer these questions, especially in plants. The first hypothesis that there are specific E2s for HECT-type and RBR-type E3s that transfer ubiquitin to a cysteine on the E3 first, and different ones for RING/U box-type E3s that transfer ubiquitin to the substrate directly from the E2 is disproved with the demonstrations that the E2s human UBC1A (Ube2D3) and Arabidopsis UBC8 are active with both RING and HECT type E3s [for UBC8 data see (Bates and Vierstra, 1999; Stone et al., 2005)]. It is clear that a few E2s interact with specific E3s to produce one or more type of ubiquitination products, and the inactivity of an E2 in generic *in vitro* ubiquitination assays can be optimistically interpreted that the E2 has a preferred E3 partner not yet tested. It is clear that the E3 is the major predictor of substrate specificity, however the role E3 plays in shaping the nature of the ubiquitination product is poorly understood. Given the large number of fates for different ubiquitination products, answers to these questions will greatly enrich our understanding of cellular processes regulated by ubiquitination and how the rich information encoded in the ubiquitin protein is utilized and interpreted by various signaling pathways.

UBIQUITINATION IN PLANT BIOLOGY CONCLUDING REMARKS

The preceding paragraphs have a ubiquitination machinery-centric perspective. If we view the ubiquitin system from the perspective of the physiological processes in which the system participates, the inescapable conclusion is that the ubiquitin system is involved in almost every cellular process in plants. These include perception of the visible light spectrum and beyond, integrated with a sensing of day length and light quality. The ubiquitin system is key in responses to changes in the abiotic or biotic environment with ubiquitin-dependent responses spanning from chromatin modification and transcription factor modulation to cell surface receptor localization and/or stability. The longevity and activity of cytosolic, nuclear and chromatin-localized proteins are modulated by ubiquitin modification alone, or often linked to other post-translational modifications, such as methylation or phosphorylation. Likely most, if not all, transcription factors will be regulated, either in their activity or abundance, at some point

in their life by ubiquitination. We currently have a reasonable understanding of the proteolytic control of key transcription factors in signaling pathways for most hormones; auxin, gibberellin, jasmonate, ethylene, brassinosteroid, strigolactones, cytokinin and ABA, while a few other signaling pathways are moving in that direction (karrikin and strigolactones). Not surprising is the discovery that key enzymes in metabolic/biosynthetic pathways are controlled by ubiquitination. Disappointingly, only a few enzymes have been discovered as ubiquitin-mediated and studied in detail as to the nature of the modification and the enzymes involved. Ubiquitination regulates the *in vivo* longevity of multiple ASC isozymes (McClellan and Chang, 2008; Christians et al., 2009). In contrast, monoubiquitination specifically modulates enzymatic activity of the plant type phosphoenol pyruvate carboxylase (PEPC). Studied intensely in castor beans (Uhrig et al., 2008; O'Leary et al., 2011a), this regulatory monoubiquitination appears to be universal for plant PEPCs (O'Leary et al., 2011b). Future research should keep cognizant of regulatory monoubiquitination, currently a relatively poorly understood phenomenon, but one that will likely have important roles in plant biology, possibly rivaling ubiquitin-dependent proteolysis.

ACKNOWLEDGEMENTS

Work on the ubiquitin system in the author's laboratory has been supported by the National Science Foundation (most recently by Arabidopsis 2010 grant no MCB-0929100), US Department of Energy (DE-FG02-03ER15416, DE-FG02-09ER16077) and students were supported in part by fellowships from the National Institutes of Health Pre-doctoral T32 Training Grant (GM0007377, J. Trimmer, PI). I apologize in advance for omissions of interesting work due to time constraints. The author thanks the reviewers for helpful suggestions. All errors are those of the author.

REFERENCES

- Acconcia, F., Sigismund, S., Polo, S. (2009). Ubiquitin in trafficking: The network at work. *Exp. Cell Res.* **315**: 1610-1618.
- Aguiar-Hernández, V., Aguiar-Henonin, L., Guzmán, P. (2011). Diversity in the architecture of ATLs, a family of plant ubiquitin-ligases, leads to recognition and targeting of substrates in different cellular environments. *PLoS ONE* **6**: e23934.

- Aguilar-Hernández, V., Medina, J., Aguilar-Henonin, L., Guzmán, P.** (2013). Expansion and diversification of BTL RING-H2 ubiquitin ligases in angiosperms: Putative Rabring7/BCA2 orthologs. *PLoS ONE* **8**: e72729.
- Andersen, P., Kragelund, B.B., Olsen, A.N., Larsen, F.H., Chua, N.H., Poulsen, F.M., Skriver, K.** (2004). Structure and biochemical function of a prototypical Arabidopsis U-box domain. *J. Biol. Chem.* **279**: 40053-40061.
- Aung, K., Lin, S., Wu, C., Huang, Y., Su, C., Chiou, T.** (2006). *Pho2*, a phosphate overaccumulator, is caused by a non-sense mutation in a microRNA399 target gene. *Plant Physiol.* **141**: 1000-1011.
- Azevedo, C., Santos-Rosa, M., Shirasu, K.** (2001). The U-box protein family in plants. *Trends Plant Sci.* **6**: 354-358.
- Azevedo, J., Courtois, F., Hakimi, M.A., Demarsy, E., Lagrange, T., Alcaraz, J.P., Jaiswal, P., Marechal-Drouard, L., Lerbs-Mache, S.** (2008). Intraplastidial trafficking of a phage-type RNA polymerase is mediated by a thylakoid RING-H2 protein. *Proc. Natl. Acad. Sci. USA* **105**: 9123-9128.
- Bachmair, A., Finley, D., Varshavsky, A.** (1986). In vivo half-life of a protein is a function of its amino-terminal residue. *Science* **234**: 179-186.
- Bachmair, A., Novatchkova, M., Potuschak, T., Eisenhaber, F.** (2001). Ubiquitylation in plants: A post-genomic look at a post-translational modification. *Trends Plant Sci.* **6**: 463-470.
- Bailey-Serres, J., Fukao, T., Gibbs, D.J., Holdsworth, M.J., Lee, S.C., Licausi, F., Perata, P., Voesenek, L.A., van Dongen, J.T.** (2012). Making sense of low oxygen sensing. *Trends Plant Sci.* **17**: 129-138.
- Bari, R., Datt Pant, B., Stitt, M., Scheible, W.** (2006). PHO2, microRNA399, and PHR1 define a phosphate-signaling pathway in plants. *Plant Physiol.* **141**: 988-999.
- Bartling, D., Rehling, P., Weiler, E.W.** (1993). Functional expression and molecular characterization of AtUBC2-1, a novel ubiquitin-conjugating enzyme (E2) from *Arabidopsis thaliana*. *Plant Mol. Biol.* **23**: 387-396.
- Bates, P.W., Vierstra, R.D.** (1999). UPL1 and 2, two 405 kDa ubiquitin-protein ligases from *Arabidopsis thaliana* related to the HECT-domain protein family. *Plant J.* **20**: 183-195.
- Behrends, C., Harper, J.W.** (2011). Constructing and decoding unconventional ubiquitin chains. *Nat. Struct. Mol. Biol.* **18**: 520-528.
- Bergler, J., Hoth, S.** (2011). Plant U-box armadillo repeat proteins AtPUB18 and AtPUB19 are involved in salt inhibition of germination in Arabidopsis. *Plant Biol.* **13**: 725-730.
- Berrocal-Lobo, M., Stone, S., Yang, X., Antico, J., Callis, J., Ramonell, K.M., Somerville, S.** (2010). ATL9, a RING zinc finger protein with E3 ubiquitin ligase activity implicated in chitin- and NADPH oxidase-mediated defense responses. *Plos ONE* **5**: e14426.
- Book, A.J., Gladman, N.P., Lee, S.S., Scalf, M., Smith, L.M., Vierstra, R.D.** (2010). Affinity purification of the Arabidopsis 26S proteasome reveals a diverse array of plant proteolytic complexes. *J. Biol. Chem.* **285**: 25554-25569.
- Book, A.J., Smalle, J., Lee, K.H., Yang, P., Walker, J.M., Casper, S., Holmes, J.H., Russo, L.A., Buzzinotti, Z.W., Jenik, P.D., Vierstra, R.D.** (2009). The RPN5 subunit of the 26S proteasome is essential for gametogenesis, sporophyte development, and complex assembly in Arabidopsis. *Plant Cell* **21**: 460-478.
- Bostick, M., Lochhead, S.R., Honda, A., Palmer, S., Callis, J.** (2004). RELATED TO UBIQUITIN1 and 2 are redundant and essential and regulate vegetative growth, auxin signaling, and ethylene production in Arabidopsis. *Plant Cell* **16**: 2418-2432.
- Bratzel, F., Lopez-Torrejon, G., Koch, M., Del Pozo, J.C., Calonje, M.** (2010). Keeping cell identity in Arabidopsis requires PRC1 RING-finger homologs that catalyze H2A monoubiquitination. *Curr. Biol.* **20**: 1853-1859.
- Bremm, A., Freund, S., Komander, D.** (2010). Lys11-linked ubiquitin chains adopt compact conformations and are preferentially hydrolyzed by the deubiquitinase cezanne. *Nat. Struct. Mol. Biol.* **17**: 939-947.
- Burke, T., Callis, J., Vierstra, R.D.** (1988). Characterization of a polyubiquitin gene from *Arabidopsis thaliana*. *Mol. Gen. Genet.* **213**: 435-443.
- Callis, J., Carpenter, T., Sun, C.W., Vierstra, R.D.** (1995). Structure and evolution of genes encoding polyubiquitin and ubiquitin-like proteins in *Arabidopsis thaliana* ecotype Columbia. *Genetics* **139**: 921-939.
- Callis, J., Pollmann, L., Shanklin, J., Wettren, M., Vierstra, R.D.** (1989). Sequence of a cDNA from *Chlamydomonas reinhardtii* encoding a ubiquitin 52 amino acid extension protein. *Nucl. Acids Res.* **17**: 8377.
- Callis, J., Raasch, J.A., Vierstra, R.** (1990). Ubiquitin extension proteins of *Arabidopsis thaliana*: structure, localization and expression of their promoters in transgenic tobacco. *J. Biol. Chem.* **265**: 12486-12493.
- Callis, J., Vierstra, R.D.** (1989). Ubiquitin and ubiquitin genes in higher plants. *Oxford Surveys in Plant Mol. Biol.* **6**: 1-30.
- Calonje, M.** (2014). PRC1 marks the difference in plant PcG repression. *Mol. Plant* **7**: 459-471.
- Cao, Y., Dai, Y., Cui, S., Ma, L.** (2008). Histone H2B monoubiquitination in the chromatin of flowering locus C regulates flowering time in Arabidopsis. *Plant Cell* **20**: 2586-2602.
- Carvalho, S.D., Saraiva, R., Maia, T.M., Abreu, I.A., Duque, P.** (2012). XBAT35, a novel Arabidopsis RING E3 ligase exhibiting dual targeting of its splice isoforms, is involved in ethylene-mediated regulation of apical hook curvature. *Mol. Plant* **5**: 1295-1309.
- Chen, D., Molitor, A., Liu, C.F., Shen, W.-H.** (2010). The Arabidopsis PRC1-like ring-finger proteins are necessary for repression of embryonic traits during vegetative growth. *Cell Res.* **20**: 1332-1344.
- Chen, H., Shen, Y., Tang, X., Yu, L., Wang, J., Guo, L., Zhang, Y., Zhang, H., Feng, S., Strickland, E., Zheng, N., Deng, X.W.** (2006). Arabidopsis CULLIN4 forms an E3 ubiquitin ligase with RBX1 and the CDD complex in mediating light control of development. *Plant Cell* **18**: 1991-2004.
- Chen, Z.H., Grefen, C., Donald, N., Hills, A., Blatt, M.** (2011). A bicistronic, ubiquitin-10 promoter-based vector cassette for transient transformation and functional analysis of membrane transport demonstrates the utility of quantitative voltage clamp studies on intact Arabidopsis root epidermis. *Plant Cell Environ.* **34**: 224-564.
- Cheng, M.-C., Hsieh, E.-J., Chen, H.-H., Chen, H.-Y., Lin, T.-P.** (2012). Arabidopsis RGLG2, functioning as a RING E3 ligase, interacts with ATERF53 and negatively regulates the plant drought stress response. *Plant Physiol.* **158**: 363-375.
- Cheng, Y.T., Li, X.** (2012). Ubiquitination in NB-LRR-mediated immunity. *Curr. Opin. Plant Biol.* **15**: 392-399.
- Choi, C., Gray, W.M., Mooney, S., Hellmann, H.** (2014) Composition, roles and regulation of cullin-based ubiquitin E3 ligases. *The Arabidopsis Book*, in press.
- Christians, M.J., Gingerich, D.J., Hansen, M., Binder, B.M., Kieber, J.J., Vierstra, R.D.** (2009). The BTB ubiquitin ligases ETO1, EOL1 and EOL2 act collectively to regulate ethylene biosynthesis in Arabidopsis by controlling type-2 ACC synthase levels. *Plant J.* **57**: 332-345.
- Chuang, T.H., Ulevitch, R.J.** (2004). Triad3a, an E3 ubiquitin-protein ligase regulating toll-like receptors. *Nat. Immunol.* **5**: 495-502.
- Ciechanover, A., Elias, S., Heller, H., Hershko, A.** (1982). Covalent affinity purification of ubiquitin-activating enzyme. *J. Biol. Chem.* **257**: 2537-2542.
- Ciechanover, A., Heller, H., Elias, S., Haas, A.L., Hershko, A.** (1980). ATP-dependent conjugation of reticulocyte proteins with the polypeptide required for protein degradation. *Proc. Natl. Acad. Sci. USA* **77**: 1365-1368.
- Ciechanover, A., Heller, H., Katz-Etzion, R., Hershko, A.** (1981). Activation of the heat-stable polypeptide of the ATP-dependent proteolytic

- system. *Proc. Natl. Acad. Sci. USA* **78**: 761-765.
- Ciechanover, A., Hod, Y., Hershko, A.** (1978). A heat stable polypeptide component of an ATP-dependent proteolytic system from reticulocytes. *Biochem. Biophys. Res. Commun.* **81**: 1100-1105.
- Cook, W.J., Jeffrey, L.C., Sullivan, M.L., Vierstra, R.D.** (1992). Three-dimensional structure of a ubiquitin-conjugating enzyme (E2). *J. Biol. Chem.* **267**: 15116-15121.
- Criqui, M.C., de Almeida Engler, J., Camasses, A., Capron, A., Parmentier, Y., Inze, D., Genschik, P.** (2002). Molecular characterization of plant ubiquitin-conjugating enzymes belonging to the UbcP4/E2-C/UBCx/UbcH10 gene family. *Plant Physiol.* **130**: 1230-1240.
- Cui, F., Liu, L.J., Li, Q.L., Yang, C.W., Xie, Q.** (2012a). UBC32 mediated oxidative tolerance in Arabidopsis. *J. Genet. Genom.* **39**: 415-417.
- Cui, F., Liu, L.J., Zhao, Q.Z., Zhang, Z.H., Li, Q.L., Lin, B.Y., Wu, Y.R., Tang, S.Y., Xie, Q.** (2012b). Arabidopsis ubiquitin conjugase UBC32 is an ERAD component that functions in brassinosteroid-mediated salt stress tolerance. *Plant Cell* **24**: 233-244.
- Cyr, D., Hohfeld, J., Patterson, C.** (2002). Protein quality control: U-box-containing E3 ubiquitin ligases join the field. *Trends Biochem. Sci.* **27**: 368-375.
- Czechowski, T., Stitt, M., Altmann, T., Udvardi, M., Scheible, W.** (2005). Genome-wide identification and testing of superior reference genes for transcript normalization in Arabidopsis. *Plant Physiol.* **139**: 5-17.
- Das, R., Liang, Y.H., Mariano, J., Li, J., Huang, T., King, A., Tarasov, S.G., Weissman, A.M., Ji, X., Byrd, R.A.** (2013). Allosteric regulation of E2:E3 interactions promote a processive ubiquitination machine. *EMBO J.* **32**: 2504-2516.
- Das, R., Mariano, J., Tsai, Y.C., Kalathur, R.C., Kostova, Z., Li, J., Tarasov, S.G., McFeeters, R.L., Altieri, A.S., Ji, X., Byrd, R.A., Weissman, A.M.** (2009). Allosteric activation of E2-RING finger-mediated ubiquitylation by a structurally defined specific E2-binding region of gp78. *Molecular Cell* **34**: 674-685.
- Deng, X.W., Matsui, M., Wei, N., Wagner, D., Chu, A.M., Feldmann, K.A., Quail, P.H.** (1992). COP1, an Arabidopsis regulatory gene, encodes a protein with both a zinc-binding motif and a G beta homologous domain. *Cell* **71**: 791-801.
- Dikic, I., Wakatsuki, S., Walters, K.J.** (2009). Ubiquitin-binding domains—from structures to functions. *Nat. Rev. Mol. Cell Biol.* **10**: 659-671
- Doukhanina, E.V., Chen, S., van der Zalm, E., Godzik, A., Reed, J., Dickman, M.B.** (2006). Identification and functional characterization of the BAG protein family in Arabidopsis thaliana. *J. Biol. Chem.* **281**: 18793-18801.
- Dowil, R.T., Lu, X., Saracco, S.A., Vierstra, R.D., Downes, B.P.** (2011). Arabidopsis membrane-anchored ubiquitin-fold (MUB) proteins localize a specific subset of ubiquitin-conjugating (E2) enzymes to the plasma membrane. *J. Biol. Chem.* **286**: 14913-14921.
- Downes, B.P., Saracco, S.A., Lee, S.S., Crowell, D.N., Vierstra, R.D.** (2006). MUBs, a family of ubiquitin-fold proteins that are plasma membrane-anchored by prenylation. *J. Biol. Chem.* **281**: 27145-27157.
- Downes, B.P., Stupar, R.M., Gingerich, D.J., Vierstra, R.D.** (2003). The HECT ubiquitin-protein ligase (UPL) family in Arabidopsis: UPL3 has a specific role in trichome development. *Plant J.* **35**: 729-742.
- Drechsel, G., Bergler, J., Wippel, K., Sauer, N., Vogelmann, K., Hoth, S.** (2011). C-terminal armadillo repeats are essential and sufficient for association of the plant U-box armadillo E3 ubiquitin ligase SAUL1 with the plasma membrane. *J. Exp. Bot.* **62**: 775-785.
- Duda, D.M., Olszewski, J.L., Schuermann, J.P., Kurinov, I., Miller, D.J., Nourse, A., Alpi, A.F., Schulman, B.A.** (2013). Structure of HHARI, a RING-IBR-RING ubiquitin ligase: Autoinhibition of an ariadne-family E3 and insights into ligation mechanism. *Structure* **21**: 1030-1041.
- Duek, P.D., Elmer, M.V., van Oosten, V.R., Fankhauser, C.** (2004). The degradation of HFR1, a putative bHLH class transcription factor involved in light signaling, is regulated by phosphorylation and requires COP1. *Curr. Biol.* **14**: 2296-2301.
- Duek, P.D., Fankhauser, C.** (2005). bHLH class transcription factors take centre stage in phytochrome signalling. *Trends Plant Sci.* **10**: 51-54.
- Eifler, K.** (2010) The PHO2 family of ubiquitin conjugating enzymes in *Arabidopsis thaliana* and its contribution to plant programmed cell death University of Koln 169 pp
- El Refy, A., Perazza, D., Zekraoui, L., Valay, J.-G., Bechtold, N., Bronw, S., Hulskamp, M., Herzog, M., Bonneville, J.-M.** (2003). The Arabidopsis KAKTUS gene encodes a HECT protein and controls the number of endoreduplication cycles. *Mol. Gen. Genom.* **270**: 403-414.
- Eletr, A., Huang, D., Duda, D., Schulman, B., Kuhlman, B.** (2005). E2-conjugating enzymes must disengage from their E1 enzymes before E3-dependent ubiquitin and ubiquitin-like transfer. *Nat. Struct. Mol. Biol.* **12**: 933-934.
- Eletr, Z.M., Wilkinson, K.D.** (2014). Regulation of proteolysis by human deubiquitinating enzymes. *Biochim. Biophys. Acta* **1843**: 114-128.
- Enami, S., Arumainayagam, D., Korf, I., Rose, A.** (2013). The effects of a stimulating intron on the expression of heterologous genes in *Arabidopsis thaliana*. *Plant Biotech. J.* **11**: 555-563.
- Fan, J., Quan, S., Orth, T., Awai, C., Chory, J., Hu, J.** (2005). The Arabidopsis PEX12 gene is required for peroxisomal biogenesis and is essential for development. *Plant Physiol.* **139**: 231-239.
- Farmer, L.M., Book, A.J., Lee, K.H., Lin, Y.L., Fu, H.Y., Vierstra, R.D.** (2010). The RAD23 family provides an essential connection between the 26S proteasome and ubiquitylated proteins in Arabidopsis. *Plant Cell* **22**: 124-142.
- Favory, J.J., Stec, A., Gruber, H., Rizzini, L., Oravec, A., Funk, M., Albert, A., Cloix, C., Jenkins, G.I., Oakeley, E.J., Seidlitz, H.K., Nagy, F., Ulm, R.** (2009). Interaction of COP1 and UVR8 regulates UV-B-induced photomorphogenesis and stress acclimation in Arabidopsis. *EMBO J.* **28**: 591-601.
- Feng, J., Shen, W.-H.** (2014). Dynamic regulation and function of histone monoubiquitination in plants. *Front. Plant Sci.* **5**: article 83.
- Finley, D., Bartel, B., Varshavsky, A.** (1989). The tails of ubiquitin precursors are ribosomal proteins whose fusion to ubiquitin facilitates ribosome function. *Nature* **338**: 394-401.
- Fu, H., Lin, Y.-L., Fatimababy, A.S.** (2010). Proteasomal recognition of ubiquitylated substrates. *Trends Plant Sci.* **15**: 375-386.
- Fu, H.Y., Sadis, S., Rubin, D.M., Glickman, M., van Nocker, S., Finley, D., Vierstra, R.D.** (1998). Multiubiquitin chain binding and protein degradation are mediated by distinct domains within the 26S proteasome subunit MCB1. *J. Biol. Chem.* **273**: 1970-1981.
- Furlan, G., Klinkenberg, J., Trujillo, M.** (2012). Regulation of plant immune receptors by ubiquitination. *Front. Plant Sci.* **3**: 238.
- Galvão, R., Kota, U., Soderblom, E., Goshe, M., Boss, W.** (2008). Characterization of a new family of protein kinases from Arabidopsis containing phosphoinositide 3/4-kinase and ubiquitin-like domains. *Biochem. J.* **409**: 117-127.
- Garzon, M., Eifler, K., Faust, A., Scheel, H., Hofmann, K., Koncz, C., Yephremov, A., Bachmair, A.** (2007). PRT6/At5g02310 encodes an Arabidopsis ubiquitin ligase of the N-end rule pathway with arginine specificity and is not the CER3 locus. *FEBS Lett.* **581**: 3189-3196.
- Genschik, P., Marrocco, K., Bach, L., Noir, S., Criqui, M.C.** (2014). Selective protein degradation: A rheostat to modulate cell-cycle phase transitions. *J. Exp. Bot.* **65**: 2603-2615.
- Gibbs, D.J., Lee, S.C., Isa, N.M., Gramuglia, S., Fukao, T., Bassel, G.W., Correia, C.S., Corbineau, F., Theodoulou, F.L., Bailey-Serres, J., Holdsworth, M.J.** (2011). Homeostatic response to hypoxia is regulated by the N-end rule pathway in plants. *Nature* **479**: 415-418.

- Gibbs, D.J., Md Isa, N., Movahedi, M., Lozano-Juste, J., Mendiondo, G.M., Berckhan, S., Marin-de la Rosa, N., Vicente Conde, J., Sousa Correia, C., Pearce, S.P., Bassel, G.W., Hamali, B., Talloji, P., Tome, D.F., Coego, A., Beynon, J., Alabadi, D., Bachmair, A., Leon, J., Gray, J.E., Theodoulou, F.L., Holdsworth, M.J.** (2014). Nitric oxide sensing in plants is mediated by proteolytic control of group VII ERF transcription factors. *Mol. Cell* **53**: 369-379.
- Goldknopf, I.L., Busch, H.** (1977). Isopeptide linkage between nonhistone and histone 2A polypeptides of chromosomal conjugate-protein A24. *Proc. Natl. Acad. Sci. USA* **74**: 864-868.
- Goldstein, G., Scheid, M., Hammerling, U., Boyse, E., Schlesinger, D., Niall, H.** (1975). Isolation of a polypeptide that has lymphocyte-differentiating properties and is probably represented universally in living cells. *Proc. Natl. Acad. Sci. USA* **72**: 11-15.
- Gonda, D., Bachmair, A., Wunning, I., Tobias, J., Lane, W., Varshavsky, A.** (1989). Universality and structure of the N-end rule. *J. Biol. Chem.* **264**: 16700-16712.
- GORITSCHNIG, S., Zhang, Y.Y., Li, X.** (2007). The ubiquitin pathway is required for innate immunity in Arabidopsis. *Plant J.* **49**: 540-551.
- Graciet, E., Mesiti, F., Wellmer, F.** (2010). Structure and evolutionary conservation of the plant N-end rule pathway. *Plant J.* **61**: 741-751.
- Graciet, E., Wellmer, F.** (2010). The plant N-end rule pathway: Structure and functions. *Trends Plant Sci* **15**: 447-453.
- Gray, W.M., Hellmann, H., Dharmasiri, S., Estelle, M.** (2002). Role of the Arabidopsis RING-H2 protein RBX1 in RUB modification and SCF function. *Plant Cell* **14**: 2137-2144.
- Grefen, C., Donald, N., Schumacher, K., Blatt, M.** (2010). A ubiquitin-10 promoter-based vector set for fluorescent protein tagging facilitates temporal stability and native protein distribution in transient and stable expression studies. *Plant J.* **64**: 355-365.
- Gu, X., Jiang, D., Wang, Y.Q., Bachmair, A., He, Y.** (2009). Repression of the floral transition via histone H2B monoubiquitination. *Plant J.* **57**: 522-533.
- Guzmán, P.** (2012). The prolific ATL family of RING-H2 ubiquitin ligases. *Plant Signal. & Behav.* **7**: 1014-1021.
- Haas, A.L., Rose, I.A.** (1982). The mechanisms of ubiquitin activation enzyme: A kinetic and equilibrium analysis. *J. Biol. Chem.* **257**: 10329-10337.
- Haas, A.L., Warms, J.B.V., Rose, I.A.** (1982a). Ubiquitin adenylate: Structure and role in ubiquitin activation. *Biochemistry* **22**: 4388-4394.
- Haas, A.L., Warms, J.V.B., Hershko, A., Rose, I.A.** (1982b). Ubiquitin-activating enzyme: Mechanism and role in protein-ubiquitin conjugation. *J. Biol. Chem.* **257**: 2543-2548.
- Hanaoka, H., Noda, T., Shirano, Y., Kato, T., Hayashi, H., Shibata, D., Tabata, S., Ohsumi, Y.** (2002). Leaf senescence and starvation-induced chlorosis are accelerated by the disruption of an Arabidopsis autophagy gene. *Plant Physiol.* **129**: 1181-1193.
- Hardtke, C.S., Okamoto, H., Stoop-Myer, C., Deng, X.W.** (2002). Biochemical evidence for ubiquitin ligase activity of the Arabidopsis COP1 interacting protein 8 (CIP8). *Plant J.* **30**: 385-394.
- Hatfield, P.M., Gosink, M.M., Carpenter, T.B., Vierstra, R.D.** (1997). The ubiquitin-activating enzyme (E1) gene family in *Arabidopsis thaliana*. *Plant J.* **11**: 213-226.
- He, C., Huang, H., Xu, L.** (2013). Mechanisms guiding polycomb activities during gene silencing in *Arabidopsis thaliana*. *Front. Plant Sci.* **4**: 454.
- Hershko, A., Ciechanover, A.** (1998). The ubiquitin system. *Annu. Rev. Biochem.* **67**: 425-479.
- Hershko, A., Ferber, S., Heller, H., Elias, S., Ciechanover, A.** (1980). Characterization of the heat-stable polypeptide of the ATP-dependent proteolytic system from reticulocytes. *J. Biol. Chem.* **255**: 7525-7528.
- Hershko, A., Heller, H., Elias, S., Ciechanover, A.** (1983). Components of ubiquitin-protein ligase system. Resolution, affinity purification, and role in protein breakdown. *J. Biol. Chem.* **258**: 8206-8214.
- Heyman, J., De Veylder, L.** (2012). The anaphase-promoting complex/cyclosome in control of plant development. *Mol. Plant* **5**: 1182-1194.
- Hochstrasser, M.** (1996). Ubiquitin-dependent protein degradation. *Annu. Rev. Genet.* **30**: 405-439.
- Hochstrasser, M.** (2009). Origin and function of ubiquitin-like proteins. *Nature* **458**: 422-429.
- Holm, M., Deng, X.W.** (1999). Structural organization and interactions of COP1, a light-regulated developmental switch. *Plant Mol. Biol.* **41**: 151-158.
- Holm, M., Ma, L.G., Qu, L.J., Deng, X.W.** (2002). Two interacting bZIP proteins are direct targets of COP1-mediated control of light-dependent gene expression in Arabidopsis. *Genes Dev.* **16**: 1247-1259.
- Hundred, D., Walker, J., Mathews, D., Vierstra, R.** (1999). Use of ubiquitin fusions to augment protein expression in transgenic plants. *Plant Physiol.* **119**: 713-723.
- Hong, S., Bahn, S., Lyu, A., Jung, H., Ahn, J.** (2010). Identification and testing of superior reference genes for a starting pool of transcript normalization in Arabidopsis. *Plant Cell Physiol.* **51**: 1694-1706.
- Hong, Z., Jin, H., Tzfira, T., Li, J.** (2008). Multiple mechanism-mediated retention of a defective brassinosteroid receptor in the endoplasmic reticulum of Arabidopsis. *Plant Cell* **20**: 3418-3429.
- Hoth, S., Morgante, M., Sanchez, J.P., Hanafey, M.K., Tingey, S.V., Chua, N.H.** (2002). Genome-wide gene expression profiling in *Arabidopsis thaliana* reveals new targets of abscisic acid and largely impaired gene regulation in the *abi1-1* mutant. *J. Cell Sci.* **115**: 4891-4900.
- Hsia, M.M., Callis, J.** (2010). BRIZ1 and BRIZ2 proteins form a heteromeric E3 ligase complex required for seed germination and post-germination growth in *Arabidopsis thaliana*. *J. Biol. Chem.* **285**: 37070-37081.
- Hu, J., Aguirre, M., Peto, C., Alonso, J., Ecker, J., Chory, J.** (2002). A role for peroxisomes in photomorphogenesis and development of Arabidopsis. *Science* **297**: 405-409.
- Hua, Z., Vierstra, R.D.** (2011). The cullin-RING ubiquitin-protein ligases. *Annu. Rev. Plant Biol.* **62**: 299-334.
- Huang, X., Ouyang, X.H., Yang, P.Y., Lau, O.S., Chen, L.B., Wei, N., Deng, X.W.** (2013). Conversion from CUL4-based COP1-SPA E3 apparatus to UVR8-COP1-SPA complexes underlies a distinct biochemical function of COP1 under UV-B. *Proc. Natl. Acad. Sci. USA* **110**: 16669-16674.
- Hulskamp, M., Misera, S., Jurgens, G.** (1994). Genetic dissection of trichome cell development in Arabidopsis. *Cell* **76**: 555-566.
- Hwang, H.J., Kim, H., Jeong, Y.M., Choi, M.Y., Lee, S.Y., Kim, S.G.** (2011). Overexpression of EVE1, a novel ubiquitin family protein, arrests inflorescence stem development in Arabidopsis. *J. Exp. Bot.* **62**: 4571-4581.
- Isono, E., Nagel, M.K.** (2014). Deubiquitylating enzymes and their emerging role in plant biology. *Front. Plant Sci.* **5**: 56.
- Iyer, L.M., Burroughs, A.M., Aravind, L.** (2006). The prokaryotic antecedents of the ubiquitin-signaling system and the early evolution of ubiquitin-like beta-grasp domains. *Genome Biol.* **7**: R60.
- Jang, S., Marchal, V., Panigrahi, K.C., Wenkel, S., Soppe, W., Deng, X.W., Valverde, F., Coupland, G.** (2008). Arabidopsis COP1 shapes the temporal pattern of CO accumulation conferring a photoperiodic flowering response. *EMBO J.* **27**: 1277-1288.
- Jarvis, P., Lopez-Juez, E.** (2013). Biogenesis and homeostasis of chloroplasts and other plastids. *Nat. Rev. Mol. Cell Biol.* **14**: 787-802.
- Johnson, M., von Besser, K., Zhou, Q., Smith, E., Aux, G., Patton, D., Levin, J., Preuss, D.** (2004). Arabidopsis hapless mutations define essential gametophytic functions. *Genetics* **168**: 971-982.

- Ju, H.-W., Min, J.-H., Chung, M.-S., Kim, C.S. (2013). The *atrzf1* mutation of the novel RING-type E3 ubiquitin ligase increases proline contents and enhances drought tolerance in *Arabidopsis*. *Plant Sci.* **203-204**: 1-7.
- Kawasaki, T., Nam, J., Boyes, D.C., Holt, B.F., Hubert, D.A., Wiig, A., Dangi, J.L. (2005). A duplicated pair of *Arabidopsis* RING-finger E3 ligases contribute to the RPM1- and RPS2-mediated hypersensitive response. *Plant J.* **44**: 258-270.
- Kim, D.-Y., Scalf, M., Smith, L., Vierstra, R. (2013). Advanced proteomic analyses yield a deep catalog of ubiquitylation targets in *Arabidopsis*. *Plant Cell* **25**: 1523-1540.
- Kim, S.J., Kim, W.T. (2013). Suppression of *Arabidopsis* RING E3 ubiquitin ligase *AtATL78* increases tolerance to cold stress and decreases tolerance to drought stress. *FEBS Lett.* **587**: 2584-2590.
- Kim, S.J., Ryu, M.Y., Kim, W.T. (2012). Suppression of *Arabidopsis* RING-DUF1117 E3 ubiquitin ligases, *AtRDUF1* and *AtRDUF2*, reduces tolerance to ABA-mediated drought stress. *Biochem. Biophys. Res. Commun.* **420**: 141-147.
- Kirkin, V., Dikic, I. (2007). Role of ubiquitin- and Ubl-binding proteins and cell signaling. *Curr. Opin. Cell Biol.* **19**: 197-205.
- Kiyosue, T., Yamaguchi-Shinozaki, K., Shinozaki, K. (1994). Cloning of cDNAs for genes that are early-responsive to dehydration stress (ERDs) in *Arabidopsis thaliana* L.: Identification of three ERDs as HSP cognate genes. *Plant Mol. Biol.* **25**: 791-798.
- Komander, D., Rape, M. (2012). The ubiquitin code. *Annu. Rev. Biochem.* **81**: 203-229.
- Kosarev, P., Mayer, K.F., Hardtke, C.S. (2002). Evaluation and classification of RING-finger domains encoded by the *Arabidopsis* genome. *Genome Biol.* **3**: RESEARCH0016.
- Kraft, E., Stone, S.L., Ma, L., Su, N., Gao, Y., Lau, O.-S., Deng, X.-W., Callis, J. (2005). Genome analysis and functional characterization of the E2 and RING domain E3 ligase ubiquitination enzymes of *Arabidopsis thaliana*. *Plant Physiol.* **139**: 1597-1611.
- Kulathu, Y., Komander, D. (2012). Atypical ubiquitylation—the unexplored world of polyubiquitin beyond Lys48 and Lys63 linkages. *Nat. Rev. Mol. Cell Biol.* **13**: 508-523.
- Kurek, I., Kawagoe, Y., Jacob-Wilk, D., Doblin, M., Delmer, D. (2002). Dimerization of cotton fiber cellulose synthase catalytic subunits occurs via oxidation of the zinc-binding domains. *Proc. Natl. Acad. Sci. USA* **99**: 11109-11114.
- Lang-Mladek, C., Xie, L., Nigam, N., Chumak, N., Binkert, M., Neubert, S., Hauser, M.T. (2012). UV-B signaling pathways and fluence rate dependent transcriptional regulation of *ARIADNE12*. *Physiol. Plant.* **145**: 527-539.
- Lange, O., Lakomek, N., Fares, C., Schroder, G., Walter, K., Becker, S., Meiler, J., Grubmuller, H., Griesinger, C., de Groot, B. (2008). Recognition dynamics up to microseconds revealed from an RDC derived ubiquitin ensemble in solution. *Science* **320**: 1471-1475.
- Lau, O., Deng, X. (2008). Effect of *Arabidopsis* COP10 ubiquitin enhancement activity across E2 families and functional conservation among its canonical homologues. *Biochem. J.* **418**: 683-690.
- Lau, O.S., Deng, X.W. (2012). The photomorphogenic repressors COP1 and DET1: 20 years later. *Trends Plant Sci.* **17**: 584-593.
- Laubinger, S., Fittinghoff, K., Hoecker, U. (2004). The SPA quartet: A family of WD-repeat proteins with a central role in suppression of photomorphogenesis in *Arabidopsis*. *Plant Cell* **16**: 2293-2306.
- Laubinger, S., Marchal, V., Le Gourrierec, J., Wenkel, S., Adrian, J., Jang, S., Kulajta, C., Braun, H., Coupland, G., Hoecker, U. (2006). *Arabidopsis* SPA proteins regulate photoperiodic flowering and interact with the floral inducer CONSTANS to regulate its stability. *Development* **133**: 3213-3222.
- Lechner, E., Achard, P., Vansiri, A., Potuschak, T., Genschik, P. (2006). F-box proteins everywhere. *Curr. Opin. Plant Biol.* **9**: 631-638.
- Lechner, E., Xie, D., Grava, S., Pigaglio, E., Planchais, S., Murray, J.A., Parmentier, Y., Mutterer, J., Dubreucq, B., Shen, W.H., Genschik, P. (2002). The *AtRBX1* protein is part of plant SCF complexes, and its down-regulation causes severe growth and developmental defects. *J. Biol. Chem.* **277**: 50069-50080.
- Lee, M.J., Lee, B.-H., Hanna, J., King, R.W., Finely, D. (2011). Trimming of ubiquitin chains by proteasome-associated deubiquitinating enzymes. *Mol. Cell Proteom.* **10**: R110.003871
- Lee, S., Lee, D.W., Lee, Y., Mayer, U., Stierhof, Y.D., Lee, S., Jurgens, G., Hwang, I. (2009). Heat shock protein cognate 70-4 and an E3 ubiquitin ligase, CHIP, mediate plastid-destined precursor degradation through the ubiquitin-26S proteasome system in *Arabidopsis*. *Plant Cell* **21**: 3984-4001.
- Leitner, J., Petrasek, J., Tomanov, K., Retzer, K., Parezova, M., Korbei, B., Bachmair, A., Zazimalova, E., Luschnig, C. (2012). Lysine63-linked ubiquitylation of PIN2 auxin carrier protein governs hormonally controlled adaptation of *Arabidopsis* root growth. *Proc. Natl. Acad. Sci. USA* **109**: 8322-8327.
- Li, F., Vierstra, R.D. (2012). Autophagy: A multifaceted intracellular system for bulk and selective recycling. *Trends Plant Sci.* **17**: 526-537.
- Li, W., Ahn, I.-P., Ning, Y., Park, C.-H., Ziegler, L., Whitehill, J., Lu, H., Zhao, Q.Z., Ding, B., Xie, Q., Zhou, J.-M., Dai, L., Wang, G.-L. (2012). The U-box/arm E3 ligase PUB13 regulates cell death, defense and flowering time in *Arabidopsis*. *Plant Physiol.* **159**: 239-250.
- Li, W., Schmidt, W. (2010). A lysine-63-linked ubiquitin chain-forming conjugase, UBC13, promotes the developmental responses to iron deficiency in *Arabidopsis* roots. *Plant J.* **62**: 330-343.
- Libault, M., Wan, J., Czechowski, T., Udvardi, M., Stacey, G. (2007). Identification of 118 *Arabidopsis* transcription factor and 30 ubiquitin-ligase genes responding to chitin, a plant-defense elicitor. *Mol. Plant Microbe Interact.* **20**: 900-911.
- Licausi, F., Kosmacz, M., Weits, D.A., Giuntoli, B., Giorgi, F.M., Voeseenek, L.A., Perata, P., van Dongen, J.T. (2011). Oxygen sensing in plants is mediated by an N-end rule pathway for protein destabilization. *Nature* **479**: 419-422.
- Licausi, F., Pucciariello, C., Perata, P. (2013). New role for an old rule: N-end rule-mediated degradation of ethylene responsive factor proteins governs low oxygen response in plants. *J. Integr. Plant Biol.* **55**: 31-39.
- Lin, S.S., Martin, R., Mongrand, S., Vandenameele, S., Chen, K.C., Jang, I.C., Chua, N.H. (2008). RING1 E3 ligase localizes to plasma membrane lipid rafts to trigger FB1-induced programmed cell death in *Arabidopsis*. *Plant J.* **56**: 550-561.
- Lin, Y.L., Sung, S.C., Tsai, H.L., Yu, T.T., Radjacomare, R., Usharani, R., Fatimababy, A.S., Lin, H.Y., Wang, Y.Y., Fu, H. (2011). The defective proteasome but not substrate recognition function is responsible for the null phenotypes of the *Arabidopsis* proteasome subunit RPN10. *Plant Cell* **23**: 2754-2773.
- Ling, Q., Huang, W., Baldwin, A., Jarvis, P. (2012). Chloroplast biogenesis is regulated by direct action of the ubiquitin-proteasome system. *Science* **338**: 655-659.
- Ling, R., Colon, E., Dahmus, M.E., Callis, J. (2000). Histidine-tagged ubiquitin substitutes for wild-type ubiquitin in *Saccharomyces cerevisiae* and facilitates isolation and identification of *in vivo* substrates of the ubiquitin pathway. *Anal. Biochem.* **282**: 54-64.
- Lingard, M., Monroe-Augustus, M., Bartel, B. (2009). Peroxisome-associated matrix protein degradation in *Arabidopsis*. *Proc. Natl. Acad. Sci. USA* **106**: 4561-4566.
- Liu, L.J., Zhang, Y.C., Li, Q.H., Sang, Y., Mao, J., Lian, H.L., Wang, L., Yang, H.Q. (2008). COP1-mediated ubiquitination of CONSTANS is

- implicated in cryptochrome regulation of flowering in Arabidopsis. *Plant Cell* **20**: 292-306.
- Liu, T.-Y., Huang, T.-K., Tseng, C.-Y., Lai, Y.-S., Lin, S.-I., Lin, W.-Y., Chen, J.-W., Chiou, T.-J.** (2012). PHO2-dependent degradation of PHO1 modulates phosphate homeostasis in Arabidopsis. *Plant Cell* **24**: 2168-2183.
- Liu, Y., Koornneef, M., Soppe, W.J.** (2007). The absence of histone H2B monoubiquitination in the Arabidopsis *hub1 (rdo4)* mutant reveals a role for chromatin remodeling in seed dormancy. *Plant Cell* **19**: 433-444.
- Liu, Y.C., Wu, Y.R., Huang, X.H., Sun, J., Xie, Q.** (2011). AtPUB19, a U-box E3 ubiquitin ligase, negatively regulates abscisic acid and drought responses in *Arabidopsis thaliana*. *Mol. Plant* **4**: 938-946.
- Lu, D., Lin, W.-Y., Gao, X., Wu, S., Cheng, C., Avila, J., Heese, A., Devarenne, T., He, P., Shan, L.** (2011). Direct ubiquitination of pattern recognition receptor FLS2 attenuates plant innate immunity. *Science* **332**: 1439-1442.
- Luo, J., Shen, G., Yan, J., He, C., Zhang, H.** (2006). AtCHIP functions as an E3 ubiquitin ligase of protein phosphatase 2A subunits and alters plant response to abscisic acid treatment. *Plant J.* **46**: 649-657.
- Lyzenga, W.J., Booth, J.K., Stone, S.L.** (2012). The Arabidopsis RING-type E3 ligase XBAT32 mediates the proteasomal degradation of the ethylene biosynthetic enzyme, 1-aminocyclopropane-1-carboxylate synthase 7. *Plant J.* **71**: 23-34.
- MacGurn, J.A., Hsu, P.C., Emr, S.D.** (2012). Ubiquitin and membrane protein turnover: From cradle to grave. *Annu. Rev. Biochem.* **81**: 231-259.
- Manzano, C., Abraham, Z., Lopez-Torrejón, G., Del Pozo, J.C.** (2008). Identification of ubiquitinated proteins in Arabidopsis. *Plant Mol. Biol.* **68**: 145-158.
- Maor, R., Jones, A., Nühse, T., Studholme, D., Peck, S., Shirasu, K.** (2007). Multidimensional protein identification technology (mudpit) analysis of ubiquitinated proteins in plants. *Proteomics* **6**: 601-610.
- Marblestone, J., Butt, S., McKelvey, D., Sterner, D., Mattern, M., Nicholson, B., Eddins, M.** (2013). Comprehensive ubiquitin E2 profiling of ten ubiquitin E3 ligases. *Cell Biochem. Biophys.* **67**: 161-167.
- Marín, I.** (2010). Diversification and specialization of plant RBR ubiquitin ligases. *PLoS ONE* **5**: e11579.
- Marín, I.** (2013). Evolution of plant HECT ubiquitin ligases. *PLoS ONE* **8**: e68536.
- Marín, I., Ferrús, A.** (2002). Comparative genomics of the RBR family, including the parkinson's disease-related gene parkin and the genes of the ariadne subfamily. *Mol Biol. Evol.* **19**: 2039-2050.
- Marrocco, K., Criqui, M.C., Zervudacki, J., Schott, G., Eisler, H., Parnet, A., Dunoyer, P., Genschik, P.** (2012). APC/C-mediated degradation of dsRNA-binding protein 4 (DRB4) involved in RNA silencing. *PLoS ONE* **7**: e35173.
- McClellan, C., Chang, C.** (2008). The role of protein turnover in ethylene biosynthesis and response *Plant Sci.* **175**: 24-31.
- Meierhofer, D., Wang, X.-F., Hunag, L., Kaiser, P.** (2008). Quantitative analysis of global ubiquitination in HeLa cells by mass spectrometry. *J. Proteomic Res.* **7**: 4566-4576.
- Miao, Y., Zentgraf, U.** (2010). A HECT E3 ubiquitin ligase negatively regulates Arabidopsis leaf senescence through degradation of the transcription factor WRKY53. *Plant J.* **63**: 179-188.
- Michelle, C., Vourc'h, P., Mignon, L., Andres, C.** (2009). What was the set of ubiquitin and ubiquitin-like conjugating enzymes in the eukaryotic common ancestor? *J. Mol. Evol.* **68**: 616-628.
- Mladek, C., Guger, K., Hauser, M.T.** (2003). Identification and characterization of the ARIADNE gene family in Arabidopsis. A group of putative E3 ligases. *Plant Physiol.* **131**: 27-40.
- Molitor, A., Shen, W.-H.** (2013). The polycomb complex PRC1: Composition and function in plants. *J. Gen. Genom.* **40**: 231-238.
- Molitor, A.M., Bu, Z., Yu, Y., Shen, W.H.** (2014). Arabidopsis AL PHD-PRC1 complexes promote seed germination through H3K4me3-to-H3K27me3 chromatin state switch in repression of seed developmental genes. *PLoS Genet* **10**: e1004091.
- Morris, K., Thornber, S., Codrai, L., Richardson, C., Craig, A., Sadanandom, A., Thomas, B., Jackson, S.** (2010). DAY NEUTRAL FLOWERING represses CONSTANS to prevent Arabidopsis flowering early in short days. *Plant Cell* **22**: 1118-1128.
- Mudgil, Y., Shiu, S.H., Stone, S.L., Salt, J.N., Goring, D.R.** (2004). A large complement of the predicted Arabidopsis ARM repeat proteins are members of the U-box E3 ubiquitin ligase family. *Plant Physiol.* **134**: 59-66.
- Muralla, R., Lloyd, J., Meinke, D.** (2011). Molecular foundations of reproductive lethality in *Arabidopsis thaliana*. *PLoS ONE* **6**: e28398.
- Nodzon, L.A., Xu, W.H., Wang, Y., Pi, L.Y., Chakrabarty, P.K., Song, W.Y.** (2004). The ubiquitin ligase XBAT32 regulates lateral root development in Arabidopsis. *Plant J.* **40**: 996-1006.
- Norris, S., Meyer, S., Callis, J.** (1993). The intron of Arabidopsis polyubiquitin genes is conserved in location and is a quantitative determinant of chimeric gene expression. *Plant Mol. Biol.* **21**: 895-906.
- O'Leary, B., Fedosejevs, E.T., Hill, A.T., Bettridge, J., Park, J., Rao, S.K., Leach, C.A., Plaxton, W.C.** (2011a). Tissue-specific expression and post-translational modifications of plant- and bacterial-type phosphoenolpyruvate carboxylase isozymes of the castor oil plant, *ricinus communis* L. *J. Exp. Bot.* **62**: 5485-5495.
- O'Leary, B., Park, J., Plaxton, W.C.** (2011b). The remarkable diversity of plant PEPC (phosphoenolpyruvate carboxylase): Recent insights into the physiological functions and post-translational controls of non-photosynthetic PEPCs. *Biochem J.* **436**: 15-34.
- Oravec, A., Baumann, A., Mate, Z., Brzezinska, A., Molinier, J., Oakeley, E.J., Adam, E., Schafer, E., Nagy, F., Ulm, R.** (2006). CONSTITUTIVELY PHOTOMORPHOGENIC1 is required for the UV-B response in Arabidopsis. *Plant Cell* **18**: 1975-1990.
- Pan, I.-C., Schmidt, W.** (2014). Functional implication of K63-linked ubiquitination in the iron deficiency response of Arabidopsis roots. *Front. Plant Sci.* **4**: 542.
- Patra, B., Pattanaik, S., Yuan, L.** (2013). Ubiquitin protein ligase 3 mediates the proteasomal degradation of GLABROUS 3 and ENHANCER OF GLABROUS 3, regulators of trichome development and flavonoid biosynthesis in Arabidopsis. *Plant J.* **74**: 435-447.
- Perazza, D., Herzog, M., Hulskamp, M., Brown, S., Dorne, A., Bonnevile, J.-M.** (1999). Trichome cell growth in *Arabidopsis thaliana* can be derepressed by mutations in at least five genes. *Genetics* **152**: 461-476.
- Petroski, M.D., Deshaies, R.J.** (2005). Mechanism of lysine 48-linked ubiquitin-chain synthesis by the cullin-RING ubiquitin-ligase complex SCF-Cdc34. *Cell* **123**: 1107-1120.
- Pickart, C., Rose, I.** (1985). Functional heterogeneity of ubiquitin carrier proteins. *J. Biol. Chem.* **260**: 1573-1581.
- Platta, H., Haen, S., Reidick, C., Erdmann, R.** (2014). The peroxisomal receptor dislocation pathway: To the exportomer and beyond. *Biochimie* **98**: 16-28.
- Potuschak, T., Stary, S., Schlogelhofer, P., Becker, F., Nejnskaia, V., Bachmair, A.** (1998). PRT1 of *Arabidopsis thaliana* encodes a component of the plant N-end rule pathway. *Proc. Natl. Acad. Sci. USA* **95**: 7904-7908.
- Prasad, M.E., Schofield, A., Lyzenga, W., Liu, H., Stone, S.L.** (2010). Arabidopsis RING E3 ligase XBAT32 regulates lateral root production through its role in ethylene biosynthesis. *Plant Physiol.* **153**: 1587-1596.
- Prasad, M.E., Stone, S.L.** (2010). Further analysis of XBAT32, an Arabi-

- dopsis RING E3 ligase, involved in ethylene biosynthesis. *Plant Signal. Behav.* **5**: 1425-1429.
- Qin, F., Sakuma, Y., Tran, L.S.P., Maruyama, K., Kidokoro, S., Fujita, Y., Fujita, M., Umezawa, T., Sawano, Y., Miyazono, K.I., Tanokura, M., Shinozaki, K., Yamaguchi-Shinozaki, K.** (2008). Arabidopsis DREB2A-interacting proteins function as RING E3 ligases and negatively regulate plant drought stress-responsive gene expression. *Plant Cell* **20**: 1693-1707.
- Raab, S., Drechsel, G., Zarepour, M., Hartung, W., Koshiba, T., Bittner, F., Hoth, S.** (2009). Identification of a novel E3 ubiquitin ligase that is required for suppression of premature senescence in Arabidopsis. *Plant J.* **59**: 39-51.
- Rao-Naik, C., Delacruz, W., Laplaza, J.M., Tan, S., Callis, J., Fisher, A.J.** (1998). The rub family of proteins: Crystal structure of Arabidopsis RUB1 and expression of multiple RUBs in Arabidopsis. *J. Biol. Chem.* **273**: 34976-34982.
- Ron, M., Alandete Saez, M., Eshed Williams, L., Fletcher, J.C., McCormick, S.** (2010). Proper regulation of a sperm-specific cis-nat-siRNA is essential for double fertilization in Arabidopsis. *Genes Dev.* **24**: 1010-1021.
- Rose, A.** (2002). Requirements for intron-mediated enhancement of gene expression in Arabidopsis. *RNA* **8**: 1444-1453.
- Russell, J.D., Scalf, M., Book, A.J., Lador, D.T., Vierstra, R.D., Smith, L.M., Coon, J.J.** (2013). Characterization and quantification of intact 26S proteasome proteins by real-time measurement of intrinsic fluorescence prior to top-down mass spectrometry. *PLoS ONE* **8**: e58157.
- Salinas-Mondragón, R.E., Garcidueñas-Piña, C., Guzmán, P.** (1999). Early elicitor induction in members of a novel multigene family coding for highly related RING-H2 proteins in *Arabidopsis thaliana*. *Plant Mol. Biol.* **40**: 579-590.
- Salt, J.N., Yoshioka, K., Moeder, W., Goring, D.R.** (2011). Altered germination and subcellular localization patterns for PUB44/SAUL1 in response to stress and phytohormone treatments. *PLoS ONE* **6**: e21321.
- Santner, A., Estelle, M.** (2010). The ubiquitin-proteasome system regulates plant hormone signaling. *Plant J.* **61**: 1029-1040.
- Saracco, S.A., Hansson, M., Scalf, M., Walker, J.M., Smith, L.M., Vierstra, R.D.** (2009). Tandem affinity purification and mass spectrometric analysis of ubiquitylated proteins in Arabidopsis. *Plant J.* **59**: 344-358.
- Sato, K.** (2011). Identification of 14-3-3 proteins as a target of ATL31 ubiquitin ligase, a regulator of the C/N response in Arabidopsis. *Plant J.* **68**: 137-146.
- Scaglione, K.M., Basrur, V., Ashraf, N.S., Konen, J.R., Elenitoba-Johnson, K.S., Todi, S.V., Paulson, H.L.** (2013). The ubiquitin-conjugating enzyme (E2) Ube2w ubiquitinates the N terminus of substrates. *J. Biol. Chem.* **288**: 18784-18788.
- Schlogelhofer, P., Bachmair, A.** (2002). A test of fusion protein stability in the plant *Arabidopsis thaliana* reveals degradation signals from ACC synthase and from the plant N-end rule pathway. *Genet. Genom.* **21**: 174-179.
- Schumann, U., Wanner, G., Veenhuis, M., Schmid, M., Gietl, C.** (2003). AtPEX10, a nuclear gene essential for peroxosome and storage organelle formation during Arabidopsis embryogenesis. *Proc. Natl. Acad. Sci. USA* **100**: 9626-9631.
- Seo, D.H., Ryu, M.Y., Jammes, F., Hwang, J.H., Turek, M., Kang, B.G., Kwak, J.M., Kim, W.T.** (2012). Roles of four Arabidopsis U-box E3 ubiquitin ligases in negative regulation of abscisic acid-mediated drought stress responses. *Plant Physiol.* **160**: 556-568.
- Seo, H.S., Yang, J.Y., Ishikawa, M., Bolle, C., Ballesteros, M.L., Chua, N.H.** (2003). LAF1 ubiquitination by COP1 controls photomorphogenesis and is stimulated by SPA1. *Nature* **423**: 995-999.
- Serrano, M., Guzmán, P.** (2004). Isolation and gene expression analysis of *Arabidopsis thaliana* mutants with constitutive expression of ATL2, an early elicitor-response RING-H2 zinc-finger gene. *Genetics* **167**: 919-929.
- Serrano, M., Parra, S., Alcaraz, L.D., Guzmán, P.** (2006). The ATL gene family from *Arabidopsis thaliana* and *Oryza sativa* comprises a large number of putative ubiquitin ligases of the RING-H2 type. *J. Mol. Evol.* **62**: 434-445.
- Shen, G., Adam, Z., Zhang, H.** (2007a). The E3 ligase AtCHIP ubiquitylates FtsH1, a component of the chloroplast FtsH protease, and affects protein degradation in chloroplasts. *Plant J.* **52**: 309-321.
- Shen, G., Yan, J., Pasapula, V., Luo, J., He, C., Clarke, A.K., Zhang, H.** (2007b). The chloroplast protease subunit ClpP4 is a substrate of the E3 ligase AtCHIP and plays an important role in chloroplast function. *Plant J.* **49**: 228-237.
- Sloper-Mould, K.E., Jemc, J.C., Pickart, C.M., Hicke, L.** (2001). Distinct functional surface regions on ubiquitin. *J. Biol. Chem.* **276**: 30483-30489.
- Smalle, J., Vierstra, R.D.** (2004). The ubiquitin 26S proteasome proteolytic pathway. *Annu. Rev. Plant Biol.* **55**: 555-590.
- Smit, J.J., Sixma, T.K.** (2014). RBR E3-ligases at work. *EMBO Rep.* **15**: 142-154.
- Sparkes, I., Brandizzi, F., Slocombe, S., El-Shami, M., Hawes, C., Baker, A.** (2003). An Arabidopsis *pex10* null mutant is embryo lethal, implicating peroxisomes in an essential role during embryogenesis. *Plant Physiol.* **133**: 1809-1819.
- Spratt, D.E., Walden, H., Shaw, G.S.** (2014). RBR E3 ubiquitin ligases: New structures, new insights, new questions. *Biochem. J.* **458**: 421-437.
- Stary, S., Yin, X.J., Potuschak, T., Schlogelhofer, P., Nizhynska, V., Bachmair, A.** (2003). PRT1 of Arabidopsis is a ubiquitin protein ligase of the plant N-end rule pathway with specificity for aromatic amino-terminal residues. *Plant Physiol.* **133**: 1360-1366.
- Stone, S.L., Hauksdottir, H., Troy, A., Herschleb, J., Kraft, E., Callis, J.** (2005). Functional analysis of the RING-type ubiquitin ligase family of Arabidopsis. *Plant Physiol.* **137**: 13-30.
- Sullivan, M.L., Vierstra, R.D.** (1993). Formation of a stable adduct between ubiquitin and the Arabidopsis ubiquitin-conjugating enzyme, AtUBC1+. *J. Biol. Chem.* **268**: 8777-8780.
- Sun, C.-W., Callis, J.** (1993). Recent stable insertion of mitochondrial DNA into an Arabidopsis polyubiquitin gene by non-homologous recombination. *Plant Cell* **5**: 97-107.
- Sun, C.-W., Callis, J.** (1997). Independent modulation of *Arabidopsis thaliana* polyubiquitin mRNAs in different organs and in response to environmental changes. *Plant J.* **11**: 101-111.
- Sun, C.-W., Griffen, S., Callis, J.** (1997). A model for the evolution of polyubiquitin genes from the study of *Arabidopsis thaliana* ecotypes. *Plant Mol. Biol.* **34**: 745-758.
- Tanno, H., Komada, M.** (2013). The ubiquitin code and its decoding machinery in the endocytic pathway. *J. Biochem.* **153**: 497-504.
- Tasaki, T., Sriram, S.M., Park, K.S., Kwon, Y.T.** (2012). The N-end rule pathway. *Annu. Rev. Biochem.* **81**: 261-289.
- Tatham, M., Plechanovová, A., Jaffray, E., Selmen, H., Hay, R.** (2013). Ube2w conjugates ubiquitin to α -amino groups of protein N-termini. *Biochem J.* **453**: 137-145.
- Thoma, S., Sullivan, M.L., Vierstra, R.D.** (1996). Members of two gene families encoding ubiquitin-conjugating enzymes, AtUBC1-3 and AtUBC4-6, from *Arabidopsis thaliana* are differentially expressed. *Plant Mol. Biol.* **31**: 493-505.
- Thomann, A., Dieterle, M., Genschik, P.** (2005). Plant cullin-based E3s: Phytohormones come first. *FEBS Lett.* **579**: 3239-3245.
- Thompson, A., Doelling, J., Suttangkakul, A., Vierstra, R.** (2005). Au-

- tophagic nutrient recycling in Arabidopsis directed by the ATG8 and ATG12 conjugation pathways. *Plant Physiol.* **138**: 2097-2110.
- Thrower, J.S., Hoffman, L., Rechsteiner, M., Pickart, C.M.** (2000). Recognition of the polyubiquitin proteolytic signal. *EMBO J.* **19**: 94-102.
- Tian, M., Xie, Q.** (2013). Non-26S proteasome proteolytic role of ubiquitin in plant endocytosis and endosomal trafficking. *J. Integrat. Plant Biol.* **55**: 54-63.
- Tilbrook, K., Arongaus, A.B., Binkert, M., Heijde, M., Yin, R., Ulm, R.** (2013). The uvr8 UV-B photoreceptor: Perception, signaling and response. *Arabidopsis Book* **11**: e0164.
- Tokunaga, F., Iwai, K.** (2012). Linear ubiquitination: A novel NF- κ B regulatory mechanism for inflammatory and immune responses by the LUBAC ubiquitin ligase complex. *Endocr. J.* **59**: 641-652.
- Tomanov, K., Luschnig, C., Bachmair, A.** (2014). Ubiquitin Lys 63 chains- second most abundant, but poorly understood in plants. *Front. Plant Sci.* **5**: 15.
- Uhrig, G., She, Y.-M., Leach, C., Plaxton, W.** (2008). Regulatory monoubiquitination of phosphoenolpyruvate carboxylase in germinating castor oil seeds. *J. Biol. Chem.* **283**: 29650-29657.
- Upadhyaya, S.C., Hedge, A.N.** (2003). A potential proteasome-interacting motif within the ubiquitin-like domain of parkin and other proteins. *Trends Biochem. Sci.* **28**: 280-283.
- Van Nocker, S., Deveraux, Q., Rechsteiner, M., Vierstra, R.** (1996a). Arabidopsis MBP1 gene encodes a conserved ubiquitin recognition component of the 26S proteasome. *Proc. Natl. Acad. Sci. USA* **93**: 856-860.
- Van Nocker, S., Walker, J.M., Vierstra, R.D.** (1996b). The Arabidopsis thaliana UBC7/13/14 gene encode a family of multiubiquitin chain-forming E2 enzymes. *J. Biol. Chem.* **271**: 12150-12158.
- Varshavsky, A.** (2005). Ubiquitin fusion technique and related methods. Ubiquitin and protein degradation, pt B book series: Methods in enzymology. R Deshaies, Academic Press. **399**: 777-799
- Varshavsky, A.** (2011). The N-end rule pathway and regulation by proteolysis. *Protein Sci.* **20**: 1298-1345.
- Vierstra, R.** (2011). The ubiquitin-26S proteasome system at the nexus of plant biology. *Nature Reviews Mol. Cell Biol.* **10**: 38-397.
- Vierstra, R.** (2012). The expanding universe of ubiquitin and ubiquitin-like modifiers. *Plant Physiol.* **160**: 2-14.
- Vierstra, R.D.** (2014). Autophagy. *The Arabidopsis Book* in press
- Vijay-Kumar, S., Bugg, C.E., Cook, W.J.** (1987a). Structure of ubiquitin refined at 1.8 Å resolution. *J. Mol. Biol.* **194**: 531-544.
- Vijay-Kumar, S., Bugg, C.E., Wilkinson, K.D., Vierstra, R.D., Hatfield, P., Cook, W.J.** (1987b). Comparison of the three-dimensional structures of human, yeast, and oat ubiquitin. *J. Biol. Chem.* **262**: 6396-6399.
- Vindhya, B., Basnayake, S., Li, D., Zhang, H., Li, G., Virk, N., Song, F.** (2011). Arabidopsis DAL1 and DAL2, two RING finger proteins homologous to Drosophila DIAP1, are involved in regulation of programmed cell death. *Plant Cell Rep.* **30**: 37-48.
- Vogelmann, K., Drechsel, G., Bergler, J., Subert, C., Philippar, K., Soll, J., Engelmann, J.C., Engelsdorf, T., Voll, L.M., Hoth, S.** (2012). Early senescence and cell death in Arabidopsis *sau1* mutants involves the PAD4-dependent salicylic acid pathway. *Plant Physiol.* **159**: 1477-1487.
- von Arnim, A.G., Deng, X.W.** (1994). Light inactivation of Arabidopsis photomorphogenic repressor COP1 involves a cell-specific regulation of its nucleocytoplasmic partitioning. *Cell* **79**: 1035-1045.
- von Arnim, A.G., Osterlund, M.T., Kwok, S.F., Deng, X.W.** (1997). Genetic and developmental control of nuclear accumulation of COP1, a repressor of photomorphogenesis in Arabidopsis. *Plant Physiol.* **114**: 779-788.
- Walker, J., Vierstra, R.** (2007). A ubiquitin-based vector for the co-ordinated synthesis of multiple proteins in plants. *Plant Biotech. J.* **5**: 413-421.
- Walsh, C., Sadanandom, A.** (2014). Ubiquitin chain topology and its impact on plant cell signaling. *Front. Plant Sci.* **5**: 122.
- Wang, F., Deng, X.W.** (2011). Plant ubiquitin-proteasome pathway and its role in gibberellin signaling. *Cell Res.* **21**: 1286-1294.
- Wang, F., Zhu, D.M., Huang, X., Li, S., Gong, Y.N., Yao, Q.F., Fu, X.D., Fan, L.M., Deng, X.W.** (2009). Biochemical insights on degradation of Arabidopsis DELLA proteins gained from a cell-free assay system. *Plant Cell* **21**: 2378-2390.
- Wang, H., Lu, Y., Jiang, T., Berg, H., Li, J., Xia, Y.** (2013). The Arabidopsis U-box arm repeat E3 ligase AtPUB4 influences growth and degeneration of tapetal cells, and its mutation leads to conditional male sterility. *Plant J.* **74**: 511-523.
- Weits, D.A., Giuntoli, B., Kosmacz, M., Parlanti, S., Hubberten, H.M., Riegler, H., Hoefgen, R., Perata, P., van Dongen, J.T., Licausi, F.** (2014). Plant cysteine oxidases control the oxygen-dependent branch of the N-end-rule pathway. *Nat. Commun.* **5**: 3425.
- Wen, R., Newton, L., GLi, G., Wang, J., Xiao, W.** (2006). Arabidopsis thaliana *UBC13*: Implication of error-free DNA damage tolerance and Lys63-linked polyubiquitylation in plants. *Plant Mol. Biol.* **61**: 241-253.
- Wen, R., Torres-Acosta, A., Pastushok, L., Lai, X., Pelzer, L., Wang, H., Xiao, W.** (2008). Arabidopsis UEV1D promotes lysine-63-linked polyubiquitination and is involved in DNA damage response. *Plant Cell* **20**: 213-227.
- Wenzel, D., Lissounov, A., Brzovic, P., Klevit, R.** (2011a). UBCH7 reactivity profile reveals parkin and HHARI to be RING/HECT hybrids. *Nature* **474**: 105-109.
- Wenzel, D., Stoll, K., Klevit, R.** (2011b). E2s: Structurally economical and functionally replete. *Biochem. J.* **433**: 31-42.
- Wiborg, J., O'Shea, C., Skriver, K.** (2008). Biochemical function of typical and variant *Arabidopsis thaliana* U-box E3 ubiquitin-protein ligases. *Biochem. J.* **413**: 447-457.
- Wilkinson, K.** (2005). The discovery of ubiquitin-dependent proteolysis. *Proc. Natl. Acad. Sci. USA* **102**: 15280-15282.
- Wilkinson, K.D., Urban, M.K., Haas, A.L.** (1980). Ubiquitin is the ATP-dependent proteolysis factor 1 of rabbit reticulocytes. *J. Biol. Chem.* **255**: 7529-7532.
- Wilson, R., Edmondson, S., Flatt, J., Helms, K., Twigg, P.** (2011). The E2-25k ubiquitin-associated (UBA) domain aids in polyubiquitin chain synthesis and linkage specificity. *Biochem. Biophys. Res. Commun.* **405**: 662-666.
- Wing, S.S.** (2003). Deubiquitinating enzymes-the importance of driving in reverse along the ubiquitin-proteasome pathway. *Int. J. Biochem. Cell Biol.* **35**: 590-605.
- Worley, C.K., Ling, R.L., Callis, J.** (1998). Engineering *in vivo* instability of firefly luciferase and *E. coli* β -glucuronidase in higher plants using recognition elements from the ubiquitin pathway. *Plant Mol. Biol.* **37**: 337-347.
- Wu, P.Y., Hanlon, M., Eddins, M., Tsui, C., Rogers, R.S., Jensen, J.P., Matunis, M.J., Weissman, A.M., Wolberger, C.P., Pickart, C.M.** (2003). A conserved catalytic residue in the ubiquitin-conjugating enzyme family. *EMBO J.* **22**: 5241-5250.
- Xie, Q., Guo, H.S., Dallman, G., Fang, S.Y., Weissman, A.M., Chua, N.H.** (2002). Sinat5 promotes ubiquitin-related degradation of NAC1 to attenuate auxin signals. *Nature* **419**: 167-170.
- Xu, L., Menard, R., Berr, A., Fuchs, J., Cognat, V., Meyer, D., Shen, W.-H.** (2008). The E2 ubiquitin-conjugating enzymes, AtUBC1 and AtUBC2, play redundant roles and are involved in activation of FLC expression and repression of flowering in *Arabidopsis thaliana*. *Plant J.* **57**: 279-288.
- Xu, L., Shen, W.H.** (2008). Polycomb silencing of KNOX genes confines

- shoot stem cell niches in Arabidopsis. *Curr. Biol.* **18**: 1966-1971.
- Xu, P., Duong, D., Seyfried, N., Cheng, D., Xie, Y., Robert, J., Rusch, J., Hochstrasser, H., Finely, D., Peng, J.** (2009). Quantitative proteomics reveals the function of unconventional ubiquitin chains in proteasomal degradation. *Cell* **137**: 133-145.
- Yamada, Y., Suzuki, N.N., Hanada, T., Ichimura, Y., Kumeta, H., Fujio-ka, Y., Ohsumi, Y., Inagaki, F.** (2007). The crystal structure of ATG3, an autophagy-related ubiquitin carrier protein (E2) enzyme that mediates ATG8 lipidation. *J. Biol. Chem.* **282**: 8036-8043.
- Yan, J., Wang, J., Li, Q., Hwang, J.R., Patterson, C., Zhang, H.** (2003). AtCHIP, a U-box-containing E3 ubiquitin ligase, plays a critical role in temperature stress tolerance in Arabidopsis. *Plant Physiol.* **132**: 861-869.
- Yanagawa, Y., Sullivan, J.A., Komatsu, S., Gusmaroli, G., Suzuki, G., Yin, J., Ishibashi, T., Saijo, Y., Rubio, V., Kimura, S., Wang, J., Deng, X.W.** (2004). Arabidopsis COP10 forms a complex with DDB1 and DET1 *in vivo* and enhances the activity of ubiquitin conjugating enzymes. *Genes Dev.* **18**: 2172-2181.
- Yang, C., Bratzel, F., Hohmann, N., Koch, M., Turck, F., Calonje, M.** (2013). VAL- and AtBMI1-mediated H2Aub initiate the switch from embryonic to postgerminative growth in Arabidopsis. *Curr Biol* **23**: 1324-1329.
- Yang, C.W., Gonzalez-Lamothe, R., Ewan, R.A., Rowland, O., Yoshioka, H., Shenton, M., Ye, H., O'Donnell, E., Jones, J.D., Sadanandom, A.** (2006). The E3 ubiquitin ligase activity of arabidopsis plant U-BOX17 and its functional tobacco homolog ACRE276 are required for cell death and defense. *Plant Cell* **18**: 1084-1098.
- Yang, J., Lin, R., Sullivan, J., Hoecker, U., Liu, B., Xu, L., Deng, X.W., Wang, H.** (2005). Light regulates COP1-mediated degradation of HFR1, a transcription factor essential for light signaling in Arabidopsis. *Plant Cell* **17**: 804-821.
- Yee, D., Goring, D.** (2009). The diversity of plant U-box E3 ubiquitin ligases: From upstream activators to downstream target substrates. *J. Exp. Bot.* **60**: 1109-1121.
- Yin, W.-J., Volk, S., Ljung, K., Mehlmer, N., Dolezil, K., Ditengou, F., Hanano, S., Davis, S., Schmelzer, E., Sandberg, G., Teige, M., Palme, K., Pickart, C., Bachmair, A.** (2007). Ubiquitin lysine 63 chain-forming ligases regulate apical dominance in Arabidopsis. *Plant Cell* **19**: 1898-1911.
- Yoshida, S., Ito, M., Callis, J., Nishida, I., Watanabe, A.** (2002). A delayed leaf senescence mutant is defective in arginyl-tRNA: Protein arginyltransferase, a component of the N-end rule pathway in Arabidopsis. *Plant J.* **32**: 129-137.
- Zhang, X., Wu, Q., Ren, J., Qian, W., He, S., Huang, K., Yu, X., Gao, Y., Huang, P., An, C.** (2012). Two novel RING-type ubiquitin ligases, RGLG3 and RGLG4, are essential for jasmonate-mediated responses in Arabidopsis. *Plant Physiol.* **160**: 808-822.
- Zimmermann, P., Hirsch-Hoffmann, M., Hennig, L., Grissem, W.** (2004). Genevestigator. Arabidopsis microarray database and analysis toolbox. *Plant Physiol.* **136**: 2621-2632.
- Zolman, B., Monroe-Augustus, M., Silva, I., Bartel, B.** (2005). Isolation and functional characterization of Arabidopsis PEROXIN4 and the interacting protein PEROXIN22. *Plant Cell* **17**: 3422-3435.